

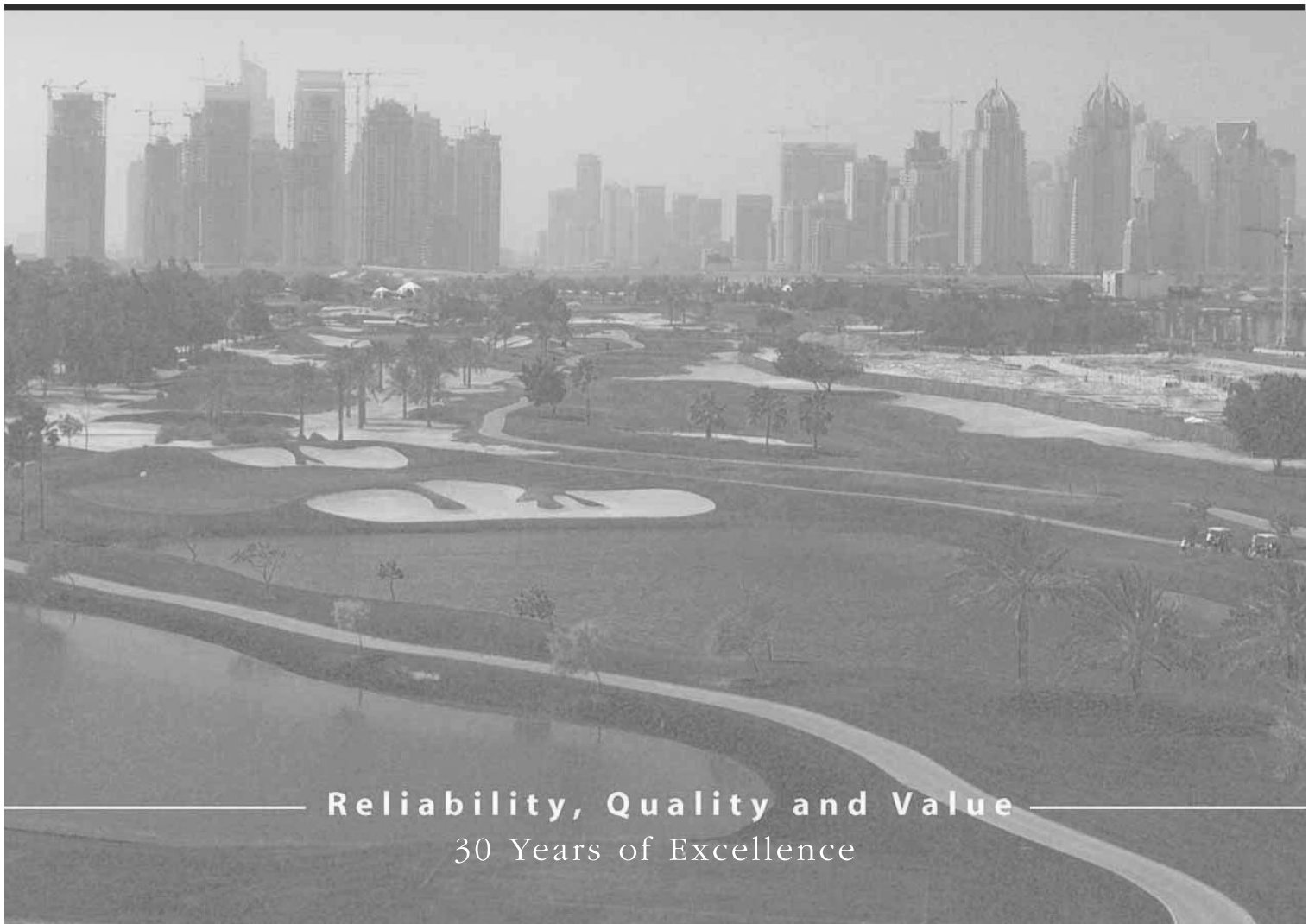

MODERN PLASTIC INDUSTRY L.L.C.



UPVC PRESSURE PIPES & FITTINGS



Reliability, Quality and Value

30 Years of Excellence

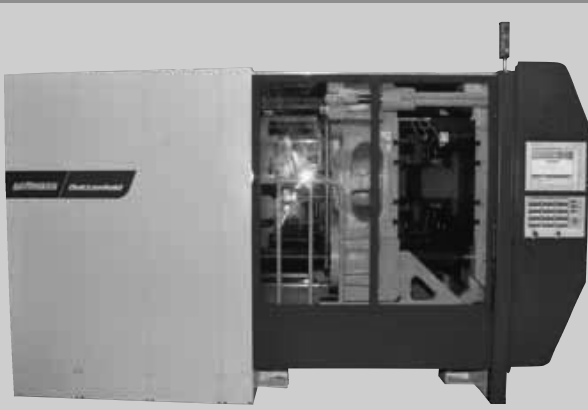

P R O F I L E

Introduction

Modern Plastic Industry is a part of AL SHIRAWI GROUP OF COMPANIES which is one of the largest and most diversified business conglomerates in the Arabian Gulf. From its inception in 1971 as a trading and contracting company, the Group has broadened its scope to encompass a cross section of products, services and industries ranging from printing, heavy fabrication, engineering, electromechanical, electronics, trucks and logistics.

Established in 1987, Modern Plastic Industry (MPI) has pioneered the manufacturing of UPVC pressure pipe fittings in the UAE. Today Modern Plastic has a wide range of SWR drainage, high pressure UPVC, CPVC, PP Compression Fittings and Pipes.

MPI products have been used extensively in the irrigation, construction, plumbing and landscaping industry and are playing a significant role in the development of the Gulf region and Middle East.

Subsequently the company started manufacturing Pressure Pipes and Fittings under the "Atlas" brands.

State-of-the-art facility

MPI UPVC Pressure Pipes and Fittings systems are manufactured in a state-of-the-art facility at Dubai Investment Park with state-of-the-art Microprocessor based Injection Moulding Machines and High Quality Precision Moulds for Fittings and High Quality Extrusion Machines for Pipes.

Technology is the backbone of ongoing development and the right design selection headed by a team of experienced and well-trained professionals complements the development process.

MPI has established an in-house tool room with the latest CNC machines and EDM machines, which are used to manufacture moulds as per the needs of the market.

Quality Control

As the UPVC High Pressure Pipe Fitting systems are specially designed to meet the harsh climate conditions of the Gulf region, MPI places emphasis on Quality, Reliability and Economy. Strict in-house Quality Control is backed by testing through independent laboratories of international repute to certify the quality of pipes and fittings.

MPI places great emphasis on customer satisfaction through quality products. The company's operational excellence is evident through its established Quality Management System, which complies with the ISO 9001-2008 standard, certified by British Standard Institute (BSI) UK. Also the company's product have been awarded the prestigious Kitemark certification of BSI, UK.

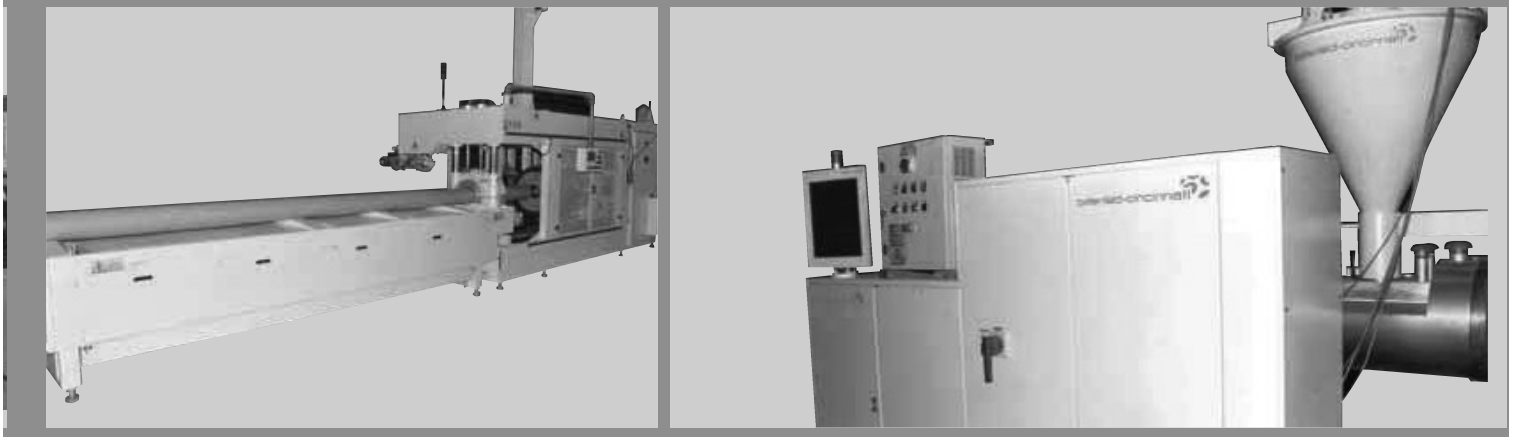

Kitemark

Modern Plastic is one of the largest companies in the Middle East to manufacture a wide range of UPVC High Pressure Pipes and Fittings Kitemark certified by BSI, UK.

WRAS

Modern Plastic manufactures wide range of UPVC high pressure pipes & fittings from material approved by WRAS.

In-House Quality Control

MPI's Products are tested to maintain the quality level in the permissible standard tolerances. We perform the tests as per relevant international standards (BS, DIN, ISO) and acceptance sampling procedures for production quality control and lot testing are done during all production operations.

The following quality control tests are performed in our in-house lab.

- Physical Test
- Dimensional Check
- Pressure Test
- Impact Test
- Heat Reversion test / Effect on Heating Test
- Dichloromethane test
- Vicat Softening Temperature Test
- Opacity Test

Apart from this, our products are being tested / assessed by BSI / other certification bodies on a regular basis.

A Complete Solution

With the growing demand to cater to the construction industry MPI has now introduced a complete range of UPVC Pressure Pipe sizes from 1/2" to 12" conforming to British Standards BS EN ISO 1452-2 which supercedes BS 3505 and sizes 20mm to 400mm conforming to DIN Standards DIN 8061 / 8062.

MPI's products are manufactured par excellence to the international standards and ensure a complete solution of "Piping System" for plumbing applications.

Global Presence

MPI has been the leader in the Gulf market mainly because it can offer the widest range of UPVC Pressure Pipes and Fittings which are specially designed to meet the harsh climatic conditions with more emphasis of Quality, Reliability and Economy. MPI is managed by a team of experienced and well trained professionals, and markets its range of products in the AGCC region, the Middle East, Africa, Europe and the Asian subcontinent.



TECHNICAL SPECIFICATION

UPVC PRESSURE PIPES AND FITTINGS

Description

"Atlas" Pipe Fittings are the "UPVC (Unplasticized Polyvinyl Chloride) Pressure Pipes and Fittings system" for cold water distribution, precisely designed for cold solvent welding as well as rubber ring jointing. The complete range can also be offered in CPVC (Chlorinated Polyvinyl Chloride) material for hot water distribution on special demand.

Brand & Marking

"Atlas" is a registered brand name of "Modern Plastic Industry LLC" within United Arab Emirates for all UPVC Fittings manufactured by MPI. All fittings are marked with the brand name, size, category and standard.

Standards

UPVC Pressure Pipes & Fittings are manufactured as per the following standards.

(i) Inch series (Imperial) :

- Pressure Pipes : BS EN ISO 1452-2 : 2000
This standard supercedes BS 3505 : 1986

- Pressure Fittings : BS EN ISO 1452-3 : 2000
This standard supercedes BS 4346-3 : 1982

(ii) Millimeter series (mm) :

- Pressure Pipes : DIN 8061 / 8062
- Pressure Fittings : DIN 8063
- Threaded joints are as per BS 21 & ISO 7 – 1 standards

Working Pressure

All Pipe Fittings depending upon the sizes are made for permissible continuous working pressure at 20°C (Based on water quality) as below :

Inch system Pipe Fittings : Maximum upto 15 Bar

Millimeter system Pipe Fittings : Maximum upto 16 Bar



Types & Ranges

Pressure Fittings :

Size : (i) Inch Series (Imperial) = 1/2" to 8"
(ii) Milimeter (mm) = 20mm to 200mm

- Elbow 90°, Female Elbow 90°, Elbow 45°, Reducing Female Elbow 90°, Tee, Female Tee & "Y"
- Reducing Tee, Reducing Female Tee, End Cap Plain, Threaded Cap, Male Thread Adaptor
Female Socket Adaptor, Female Slip Adaptor, Socket, Reducer Bushes, Female Reducer Bushes
Hex Nipples, Flanges, Unions, Repair Socket, Converter Socket, Reducing Socket.

Pressure Pipes :

Size : (i) Inch Series (Imperial) = 1/2" to 12"
(ii) Milimeter Series (mm) = 20mm to 160mm

Raw Material

The raw material used is 100 % UPVC virgin material with necessary additives / chemicals needed to facilitate the manufacturing process.

Appearance

The internal and external surface of the pipes are smooth, clean and free from surface defects.

Colour

The colour of the Pipe Fittings are Grey throughout the wall.

Effective Length of Pressure Pipes

All pipes are manufactured in 4m and 6 / 5.8m lengths.

Pressure Pipe Sockets

The Pipes are supplied as follows.

The inch size pipes from 1/2" to 2" and "mm" size pipes from 20mm to 63mm are supplied with plain ends.

The inch size pipes from 3" to 12" and "mm" size pipes from 75mm to 400mm are supplied with Solvent cement socket or rubber ring socket.

General Physical Properties of UPVC

Sr. No	Characteristics	Value
1	Specific Gravity	1.41
2	Thermal Conductivity	160 w/m° C
3	Specific Heat	1040 J / Kg°C
4	Flammability	UPVC is self – extinguishing and will not support combustion
5	Tensile Strength	> 45 MN/sq cm at 20° C
6	Vicat Softening Temperature	>80°C
7	Poissons Ratio	1:3
8	Termal Expantion Co efficient	0.07...0.08 Mm/mK
9	Heat Conductivity at 23 c	0.15 W/mk
10	Water absorbation at 23 c	<0.1%



Mechanical and Physical Properties : UPVC Pipes

Sr. No	Characteristics	Value	Value
1	Impact Strength	TIR <10% at 0° C	EN 744
2	Vicat Softening Temperature	>80°C	EN 727
3	Longitudinal Reversion	<5 % at 150° C	EN 743 (Method B ; Air)
4	Resistance to Dichloromethane Test	No attack at any part of the surface of pipe at 15°C	EN 580
5	Opacity	Shall not transmit >0.2% of visible light	EN 578
6	Resistance to Internal Pressure	No failure during the test period of 1 hr at 20°C ; 42 Mpa	EN 921

Mechanical and Physical Properties : UPVC Fittings

Sr. No	Characteristics	Value	Value
1	Vicat Softening Temperature	>74°C	EN 727
2	Effects on Heating	Depth of crack / delamination, blisters or signs of weld line splitting < 30% of wall thickness around injection point	EN 743 (Method B ; Air)
3	Opacity	Shall not transmit >0.2% of visible light	EN 578
4	Resistance to Internal Pressure of 1 hr at 20°C ; 3.36 x PN	No failure during the test period	ISO / DIS 12092

Chemical Resistance

UPVC Pressure Pipe systems are suitable to be used with a number of acids, alkalies, salts and solvents that can be mixed with water.

UPVC Pressure Pipe systems are not resistant to aromatic and chlorinated hydrocarbons.

More detailed and specific information is available on pages 32 - 35 & in the British Standard code of practice for plastic pipe work CP 312-3 : 1973

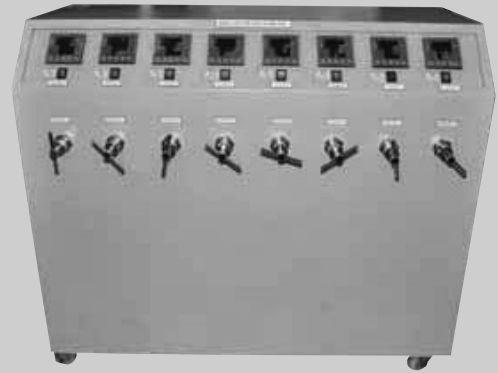

ON SITE STORAGE AND HANDLING

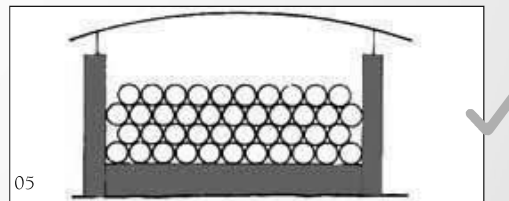
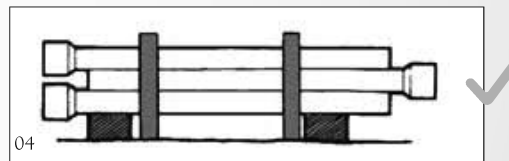
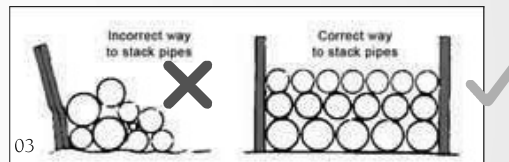
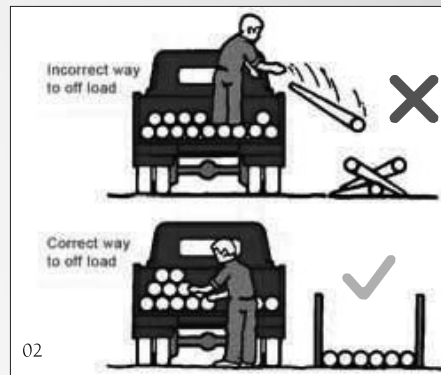
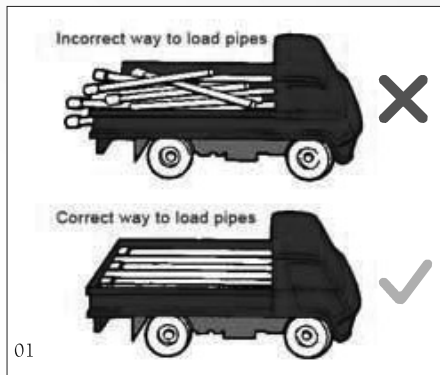

Storage

- The pipes should be kept on a flat surface or on level ground free from stones and sharp objects.
- The maximum stack should be 7 layers high under normal conditions and 6 layers high in hot conditions.
- Ideally a stack should contain pipes of the same diameter. If this is not possible nesting of the smaller pipes inside the larger pipes may be done. The larger diameter pipes should always be kept at the bottom of the stack.
- Direct exposure to sunlight (UV rays) can affect the pipes and fittings, causing decolouration and deterioration in the seal rings.
- It is recommended that the pipes should not be exposed to direct sunlight and if kept in open for longer periods of direct sunlight, it should be covered by opaque sheets.
- While storing socketed pipes, it is recommended that alternate layers should have the sockets in the opposite direction.



Handling

- Reasonable care should be taken while handling of pipes. During unloading from vehicles, pipes should not be dropped/mishandled from the vehicle.
- Pipes should never be dragged along hard surfaces. In case of mechanical lifting, avoid using metal chains and hooks in direct contact with the pipes. It is recommended to provide protected slings and padded supports.

Transportation

- Generally UPVC pipes are supplied in prepacked bundles of standard quantity.
- In case loose pipes being transported, the larger diameter and heavier pipes should be placed at the bottom of the load and smaller diameter pipes on top.
- The pipes should be loaded in such a way that the overhang should be less than a meter.



PVC PIPING SYSTEM: Brief Technical Overview

Temperature / Pressure Relationship

The service life of a pipe system is influenced by the relationship between the working temperature and the working pressure. Illustration 'A' below plots the recommended maximum working pressures in relation to working temperatures, based upon a service life expectancy of 50 years for 15 bar fittings.

It is appreciated, in the context of modern industrial pipe system, reference to service life of 50 years, or even 20 years may be largely irrelevant. Such a time scale is, however, used only as a basis of material provided maximum combinations of pressure and temperature are not exceeded.

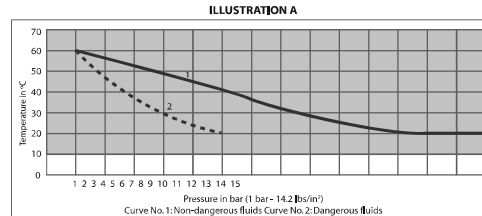
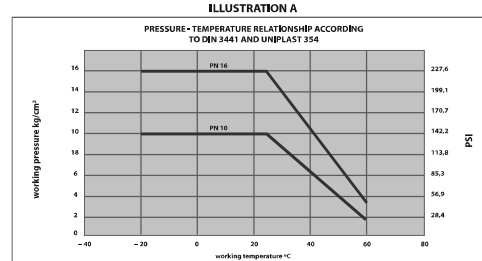

Illustration 'B' below plot, the recommended maximum working pressures in relation to working temperatures, based upon a service life expectancy of 50 years for metric size fittings for 16 & 10 bar fittings.



THE ABOVE DATA HAS BEEN TAKEN FROM BURST & AGING TESTS ON A RANDOM SAMPLING BASIS CARRIED OUT UNDER RELEVANT TEST CONDITIONS

Determining the Pressure Rating of a System

In determining the maximum working pressure of system as whole, it is essential to take into consideration those components in the system which have the lowest pressure rating. PVC pipe, for example, is available with pressure ratings ranging from 6 bar (Class B) up to 15 bar (Class E), and it is frequently the pressure class of the pipe that will determine the performance capability of the whole system.

Pressure ratings of pipe fittings and values are always quoted with and subjected to a given temperature, usually 20° C. They can be used at higher pressures, but it is a fundamental principle in plastics pipe work that if either the temperature or the pressure is increased then the other must be reduced.

The table below shows the percentage of system's overall pressure rating recommended for various working temperature over 20° C with a fluctuation not exceeding 5° C. Where pipe work is conveying highly corrosive or dangerous liquids, or is liable to mechanical abuse, it is recommended that the pressure rating be regarded as that applicable to the next lower pressure class.

Temperature		Percentage of Pressure Rating	W.P. (BAR)	
deg. C	deg. F		inch Size	MM Size
20	68	100	15	16
30	86	90	13.50	14.40
35	95	80	12	12.80
40	104	70	10.50	11.20
45	113	60	9	9.60
50	122	45	6.75	7.20
55	131	30	4.50	4.80
60	140	15	2.25	2.40



PIPE JOINTING TECHNIQUES

Solvent cement Jointing



1 The socket and spigot to be jointed shall be thoroughly seen for any damage. Proper attention shall be given to spigot chamfer and socket.

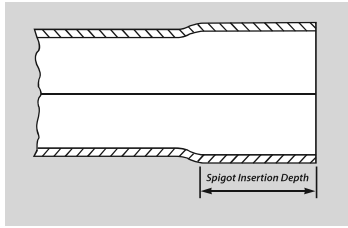

2 The spigot insertion depth shall be measured as the depth from the mouth to the shoulder of the socket. The spigot shall be marked accordingly with marker. (REFER FIG 1 & 3)



3 The mating area of spigot and socket shall be thoroughly cleaned. (REFER FIG 2 & 3)



4 Lightly roughen the mating surface of the spigot and socket using clean emery cloth or medium glass paper. (REFER FIG 3)



5 Thoroughly clean again the mating surface and ensure that all mating surfaces are clean and completely dry. (REFER FIG 4)



6 Apply uniform coat of solvent cement to the spigot and socket mating surfaces. The cement shall be applied in a lengthwise direction and not with a circular motion. (REFER FIG 5)



7 Immediately following cement application ensure that the pipe is slowly anchored and push the spigot fully in the socket without turning the pipe. The spigot shall be inserted with a steady, continuous motion and held in place for 20 seconds. Remove the excess cement from around the mouth of the socket. (REFER FIG 6 & 7)



8 Leave the joint undisturbed for five minutes then handle with reasonable care. (REFER FIG 8)

Notes for Solvent Cement :

- 1) Solvent cement is flammable and shall be used in well ventilated conditions.
- 2) The solvent in the cement evaporates quickly, so it is recommended to close the tin/container immediately after use.
- 3) Avoid cleaning fluid be mixed with solvent cement.
- 4) Don't use brush on which solvent cement has previously hardened.
- 5) Solvent cement spilled on the pipe surface should be removed immediately.

Rubber Ring Jointing



1 The socket and spigot to be joined shall be thoroughly seen for any damage. Proper attention shall be given to spigot chamfer and the sealing ring. The chamfered spigot shall be clean and free from burrs. The sealing ring shall be correctly seated in the socket groove.

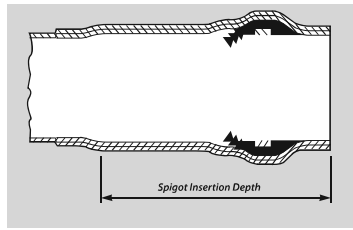

2 The spigot insertion depth shall be measured as the depth from the mouth to the shoulder of the socket. The spigot shall be marked accordingly with marker. If an allowance for expansion is required, this should be deducted from the spigot insertion depth. (REFER FIG 2)



3 The spigot and socket should be thoroughly cleaned. Any grease, dirt and other foreign matter shall be removed from the sealing areas. (REFER FIG 3)



4 The spigot end and sealing ring shall be thoroughly lubricated with the suitable lubricant. The spigot shall be lubricated to the full insertion depth and around its complete circumference including chamfer area. (REFER FIG 4)



5 Immediately after lubrication, the spigot shall be brought into contact with the socket. The spigot shall be inserted into the socket until resistance from the inner sealing section is felt. Correct alignment at this stage is essential to ensure that the rubber sealing ring is not torn or pinched. (REFER FIG 5)



- 1) All the threaded fittings must have insulated with Teflon tape for better water tightness.
- 2) The threaded fittings must have installed directly without any lubricant or solvent cement.
- 3) Before final assembly / Installation, the threads shall be tested manually for compatibility with male / female adaptor. The amount of Teflon tape to be judged based on the fitment.
- 4) The threads should be tightened by hand initially and then further one or two turns shall be sufficient to create seal.

Note: High pressure thread fittings (both male and female) are most compatible to use with similar plastic fittings. However, while connecting plastic thread it is not recommended to connect UPVC female threads with metal adaptors where overtightening is expected by the installer. Overtightening can cause stress and failure in UPVC fittings.



UPVC INCH SIZE PRESSURE PIPES AND FITTINGS

UPVC Pressure Pipes are manufactured as per the following dimensions :

Inch size Pressure Pipes : BS EN ISO 1452-2

Size	Mean Outside Dia		Wall thickness		Wall thickness		Wall thickness	
			PN - 15 (CLASS-E)		PN - 12 (CLASS-D)		PN - 9 (CLASS-C)	
	Min	Max	Min	Max	Min	Max	Min	Max
1/2"	21.2	21.5	1.7	2.1	-	-	-	-
3/4"	26.6	26.9	1.9	2.5	-	-	-	-
1"	33.4	33.7	2.2	2.8	-	-	-	-
1 1/4"	42.1	42.4	2.7	3.3	2.2	2.7	-	-
1 1/2"	48.1	48.4	3.1	3.7	2.5	3.0	-	-
2"	60.2	60.5	3.9	4.5	3.1	3.7	2.5	3.0
3"	88.7	89.1	5.7	6.6	4.6	5.3	3.5	4.1
4"	114.1	114.5	7.3	8.4	6.0	6.9	4.5	5.2
6"	168	168.5	10.8	12.5	8.8	10.2	6.6	7.6
8"	218.8	219.4	12.6	14.5	10.3	11.9	7.8	9.0
10"	272.6	273.4	15.7	18.1	12.8	14.8	9.7	11.2
12"	323.4	324.3	18.7	21.6	15.2	17.5	11.5	13.3

UPVC High Pressure Pipes to BS EN ISO 1452-2 Metric series

Size	Mean Outside Dia		Wall thickness		Wall thickness		Wall thickness	
			PN-16		PN-10		PN-6	
	Min	Max	Min	Max	Min	Max	Min	Max
20 mm	20.0	20.2	1.5	1.9	-	-	-	-
25 mm	25.0	25.2	1.9	2.3	-	-	-	-
32 mm	32.0	32.2	2.4	2.9	1.6	2.0	-	-
40 mm	40.0	40.2	3.0	3.5	1.9	2.3	1.5	1.9
50 mm	50.0	50.2	3.7	4.3	2.4	2.9	1.6	2.0
63 mm	63.0	63.2	4.7	5.4	3.0	3.5	2.0	2.4
75 mm	75.0	75.3	5.6	6.4	3.6	4.2	2.3	2.8
90 mm	90.0	90.3	6.7	7.6	4.3	5.0	2.8	3.3
110 mm	110.0	110.3	6.6	7.5	4.2	4.9	2.7	3.2
160 mm	160.0	160.4	9.5	10.7	6.2	7.1	4.0	4.6

For Water Supply, Irrigation, Drainage mains & Duct Cabling

Available in standard length of 5.8 / 6 meters with plain ends, pushfit rubber ring (for dia > 2") or solvent socket ends.

Working pressure given are based on a temperature of 20°C. UPVC Pipes derate at higher temperature.

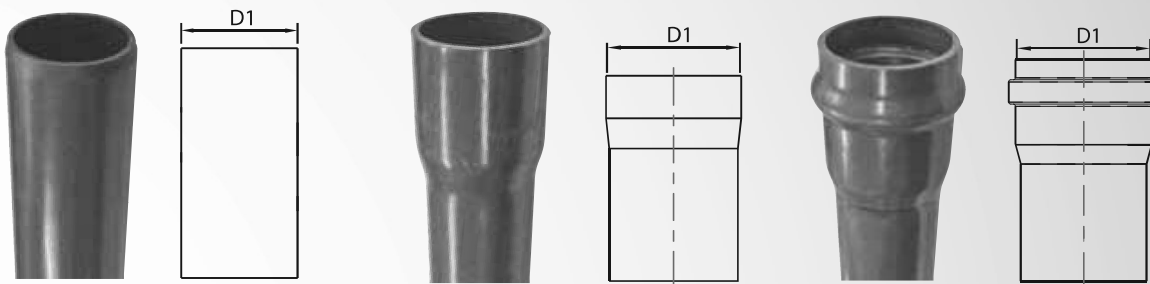

UPVC INCH SIZE PRESSURE PIPES AND FITTINGS

(BS EN ISO 1452-3; CLASS-E; PN-15)

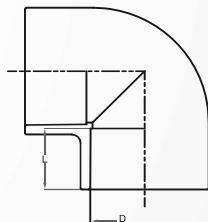

Elbow 90° Plain

Code	Size	D	L	PN
E900.5	1/2"	21.3	16.5	15
E900.75	3/4"	26.7	19.5	15
E901	1"	33.5	22.5	15
E901.25	1 1/4"	42.2	27.0	15
E901.5	1 1/2"	48.2	30.0	15
E902	2"	60.3	36.0	15
E9075X2.5	2 1/2"	75.1	44.0	15
E903	3"	88.8	50.5	15
E904	4"	114.2	63.0	15
E906	6"	168.2	90.0	15
E908	8"	219	101.6	SCH80

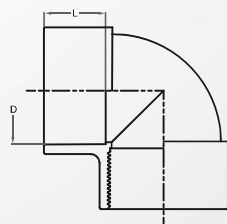

Female Elbow 90° One end plain/other end BSP female thread

Code	Size	D	L	PN
FE0.5	1/2"	21.3	16.5	15
FE0.75	3/4"	26.7	19.5	15
FE1	1"	33.5	22.5	15
FE1.25	1 1/4"	42.2	27.0	15
FE1.5	1 1/2"	48.2	30.0	15
FE2	2"	60.3	36.0	15
FE75X2.5	2 1/2"	75.1	44.0	15
FE3WOC	3"	88.8	50.5	15



UPVC INCH SIZE PRESSURE PIPES AND FITTINGS

(BS EN ISO 1452-3; CLASS-E; PN-15)

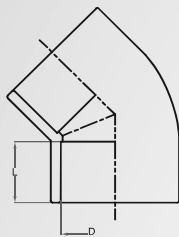

Elbow 45° Plain

Code	Size	D	L	PN
E450.5	1/2"	21.3	16.5	15
E450.75	3/4"	26.7	19.5	15
E451	1"	33.5	22.5	15
E451.25	1 1/4"	42.2	27.0	15
E451.5	1 1/2"	48.2	30.0	15
E452	2"	60.3	36.0	15
E4575	2 1/2"	75.1	44.0	15
E453	3"	88.8	50.5	15
E454	4"	114.2	63.0	15
E456	6"	168.2	90.0	15
E458	8"	219	101.6	SCH 80

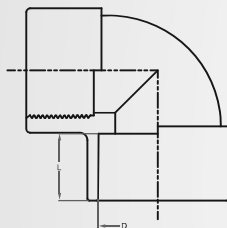

Reducing Female Elbow 90° One end plain/other end BSP female thread

Code	Size	D	L	PN
RFE 1X0.5	1 x 1/2"	33.5	22.5	15

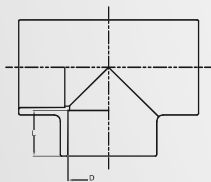

Tee 90° Plain

Code	Size	D	L	PN
T0.5	1/2"	21.3	16.5	15
T0.75	3/4"	26.7	19.5	15
T1	1"	33.5	22.5	15
T1.25	1 1/4"	42.2	27.0	15
T1.5	1 1/2"	48.2	30.0	15
T2	2"	60.3	36.0	15
T75X2.5	2 1/2"	75.1	44.0	15
T3	3"	88.8	50.5	15
T4	4"	114.2	63.0	15
T6	6"	168.2	90.0	15
T8	8"	219	101.6	SCH 80

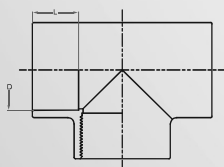

Female Tee : Two end plain/Center end BSP female thread

Code	Size	D	L	PN
FT0.5	1/2"	21.3	16.5	15
FT0.75	3/4"	26.7	19.5	15
FT1	1"	33.5	22.5	15
FT1.5	1 1/2"	48.2	30.0	15
FT2	2"	60.3	36.0	15
FT75X2.5	2 1/2"	75.1	44.0	15

UPVC INCH SIZE PRESSURE PIPES AND FITTINGS

(BS EN ISO 1452-3; CLASS-E; PN-15)

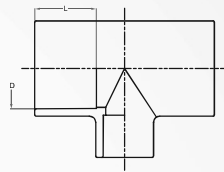

Reducing Tee

Code	Size	D	L	PN
RT0.75X0.5	3/4 x 1/2"	21.3	19.5	15
RT1X0.5	1 x 1/2"	33.5	22.5	15
RT1X0.75	1 x 3/4"	33.5	22.5	15
RT1.5X0.5	1 1/2 x 1/2"	48.2	30.0	15
RT1.5X0.75	1 1/2 x 3/4"	48.2	30.0	15
RT1.5X1	1 1/2 x 1"	48.2	30.0	15
RT2X0.5	2 x 1/2"	60.3	36.0	15
RT2X0.75	2 x 3/4"	60.3	36.0	15
RT2X1	2 x 1"	60.3	36.0	15
RT2X1.5	2 x 1 1/2"	60.3	36.0	15
RT3X2	3 x 2"	88.8	50.5	15
RT4X3	4 x 3"	114.2	63.0	15

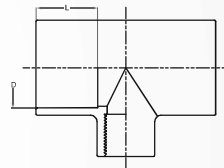

Reducing Female Tee: Two end plain/Center end BSP female thread

Code	Size	D	L	PN
RFT0.75X0.5	3/4 x 1/2"	21.3	19.5	15
RFT1X0.5	1 x 1/2"	33.5	22.5	15
RFT1X0.75	1 x 3/4"	33.5	22.5	15
RFT1.5X0.5	1 1/2 x 1/2"	48.2	30.0	15
RFT1.5X0.75	1 1/2 x 3/4"	48.2	30.0	15
RFT1.5X1	1 1/2 x 1"	48.2	30.0	15
RFT2X0.5	2 x 1/2"	60.3	36.0	15
RFT2X0.75	2 x 3/4"	60.3	36.0	15
RFT2X1	2 x 1"	60.3	36.0	15

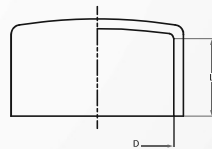
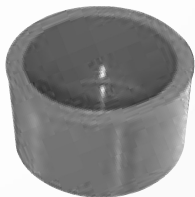

End Cap Plain

Code	Size	D	L	PN
C0.5	1/2"	21.3	16.5	15
C0.75	3/4"	26.7	19.5	15
C1	1"	33.5	22.5	15
C1.25	1 1/4"	42.2	27.0	15
C1.5	1 1/2"	48.2	30.0	15
C2	2"	60.3	36.0	15
C75X2.5	2 1/2"	75.1	44.0	15
C3	3"	88.8	50.5	15
C4	4"	114.2	63.0	15
C6	6"	168.2	90.0	15
C8	8"	219	101.6	SCH 80

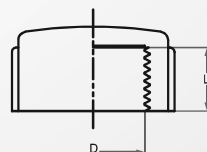

Thread Cap ; BSP female thread

Code	Size	D	PN
TC0.5	1/2"	21.3	15
TC0.75	3/4"	26.7	15
TC1	1"	33.5	15
TC1.25	1 1/4"	42.2	15
TC1.5	1 1/2"	48.2	15
TC2	2"	60.3	15
TC2.5	2 1/2"	75.1	15
TC3	3"	88.8	15
TC4	4"	114.2	15



UPVC INCH SIZE PRESSURE PIPES AND FITTINGS

(BS EN ISO 1452-3; CLASS-E; PN-15)

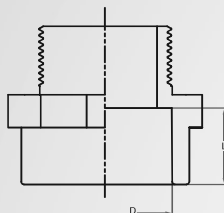

Male Thread Adaptor/Nipple Socket; BSP male thread/plain socket

Code	Size	D	L	PN
MA0.5	1/2"	21.3	16.5	15
MA0.75	3/4"	26.7	19.5	15
MA1	1"	33.5	22.5	15
MA1.25	1 1/4"	42.2	27.0	15
MA1.5	1 1/2"	48.2	30.0	15
MA2	2"	60.3	36.0	15
MA75X2.5	2 1/2"	75.1	44.0	15
MA3	3"	88.8	50.5	15
MA4	4"	114.2	63.0	15

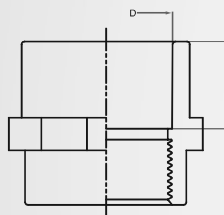
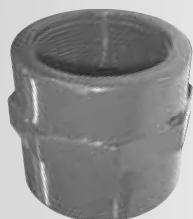

Female Socket Adaptor ; BSP female thread/plain socket

Code	Size	D	L	PN
FS0.5	1/2"	21.3	16.5	15
FS0.75	3/4"	26.7	19.5	15
FS1	1"	33.5	22.5	15
FS1.25	1 1/4"	42.2	27.0	15
FS1.5	1 1/2"	48.2	30.0	15
FS2	2"	60.3	36.0	15
FS75x2.5	2 1/2"	75.1	44.0	15
FS3	3"	88.8	50.5	15
FS4	4"	114.2	63.0	15

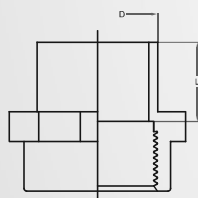

Female Slip Adaptor ; BSP female thread/male plain socket

Code	Size	D	L	PN
FSL0.5	1/2"	21.3	16.5	15
FSL0.75	3/4"	26.7	19.5	15
FSL1	1"	33.5	22.5	15
FSL1.25	1 1/4"	42.2	27.0	15
FSL1.5	1 1/2"	48.2	30.0	15
FSL2	2"	60.3	36.0	15

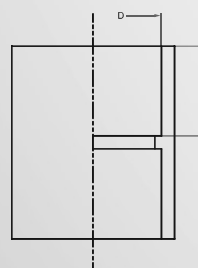

Socket

Code	Size	D	L	PN
S0.5	1/2"	21.3	16.5	15
S0.75	3/4"	26.7	19.5	15
S1	1"	33.5	22.5	15
S1.25	1 1/4"	42.2	27.0	15
S1.5	1 1/2"	48.2	30.0	15
S2	2"	60.3	36.0	15
S75X2.5	2 1/2"	75.1	44.0	15
S3	3"	88.8	50.5	15
S4	4"	114.2	63.0	15
S6	6"	168.2	90.0	15
S8	8"	219	101.6	SCH 80

UPVC INCH SIZE PRESSURE PIPES AND FITTINGS

(BS EN ISO 1452-3; CLASS-E; PN-15)

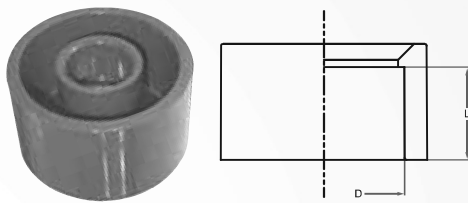

Reducer Bush				
Code	Size	D	L	PN
RB0.75X0.5	3/4 x 1/2"	21.3	19.5	15
RB1X0.5	1 x 1/2"	33.5	22.5	15
RB1X0.75	1 x 3/4"	33.5	22.5	15
RB1.25X0.5	1 1/4 x 1/2"	42.2	27.0	15
RB1.25X0.75	1 1/4 x 3/4"	42.2	27.0	15
RB1.25X1	1 1/4 x 1"	42.2	27.0	15
RB1.5X0.5	1 1/2 x 1/2"	48.2	30.0	15
RB1.5X0.75	1 1/2 x 3/4"	48.2	30.0	15
RB1.5X1	1 1/2 x 1"	48.2	30.0	15
RB2X0.5	2 x 1/2"	60.3	36.0	15
RB2X0.75	2 x 3/4"	60.3	36.0	15
RB2X1	2 x 1"	60.3	36.0	15
RB2X1.5	2 x 1 1/2"	60.3	36.0	15
RB2.5X1.5	2 1/2 x 1 1/2"	75.1	44.0	15
RB2.5X2	2 1/2 x 2"	75.1	44.0	15
RB3X1.5	3 x 1 1/2"	88.8	50.5	15
RB3X2	3 x 2"	88.8	50.5	15
RB3X2.5	3 x 2 1/2"	88.8	50.5	15
RB4X3	4 x 3"	114.2	63.0	15
RB4X2	4 x 2"	114.2	63.0	15
RB6X3	6 x 3"	168.2	90.0	15
RB6X4	6 x 4"	168.2	90.0	15
RB8X6	8 x 6"	219	101.6	SCH 80

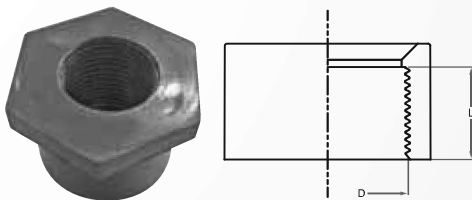

Female Reducer Bush ; BSP female thread				
Code	Size	D	L	PN
FTRRB0.75X0.5	3/4 x 1/2"	21.3	19.5	15
FTRRB1X0.5	1 x 1/2"	33.5	22.5	15
FTRRB1X0.75	1 x 3/4"	33.5	22.5	15
FTRRB1.5X0.5	1 1/2 x 1/2"	48.2	30.5	15
FTRRB2X0.5	2 x 1/2"	60.3	36.0	15

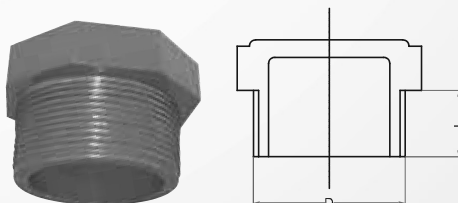

Male Plug			
Code	Size	L (mm)	PN
MTP0.5	1/2"	11.4	15
MTP0.75	3/4"	12.7	15
MTP1	1"	14.5	15
MTP1.25	1 1/4"	16.8	15
MTP1.5	1 1/2"	16.8	15



UPVC INCH SIZE PRESSURE PIPES AND FITTINGS

(BS EN ISO 1452-3; CLASS-E; PN-15)

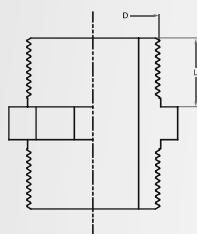

Hex Nipple

Code	Size	L (mm)	PN
HN0.5	1/2"	11.4	15
HN0.75	3/4"	12.7	15
HN1	1"	14.5	15
HN1.5	1 1/2"	16.8	15

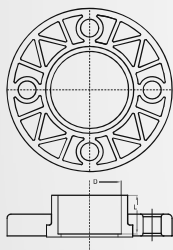

Flanges with stub

Code	Size	D	L	PN
FL2S	2"	60.3	36.0	15
FL75.2.5S	2 1/2"	75.1	44.0	15
FL3S	3"	88.8	50.5	15
FL4S	4"	114.2	63.0	15
FL6S	6"	168.2	40.0	15
FL8S	8"	168.2	90	SCH80

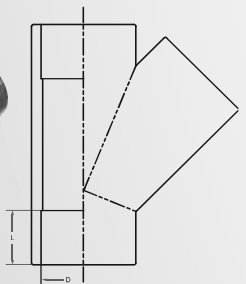

WYE 45°

Code	Size	D	L	PN
Y0.75	3/4"	26.7	19.5	15
Y1	1"	33.5	22.5	15
Y1.25	1 1/4"	42.2	27.0	15
Y1.5	1 1/2"	48.2	30.0	15
Y2	2"	60.3	36.0	15

UPVC INCH SIZE PRESSURE BRASS THREADED FITTINGS

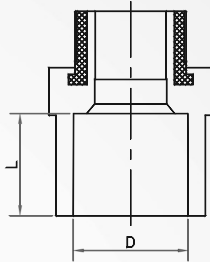

Brass Threaded Male Adaptor, BSP Threaded /Plain Socket

Code	Size	D	L	PN
MA0.5X0.5BI	1/2"	21.3	16.5	15
MA0.75X0.75BI	3/4"	26.7	19.5	15
MA1X1BI	1"	33.5	22.5	15

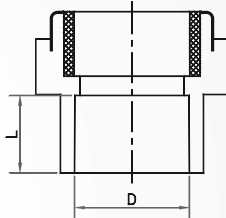

Brass Threaded Female Socket Adaptor, BSP Threaded /Plain Socket

Code	Size	D	L	PN
FS0.5X0.5BI	1/2"	21.3	16.5	15
FS0.75X0.75BI	3/4"	26.7	19.5	15
FS1X1BI	1"	33.5	22.5	15

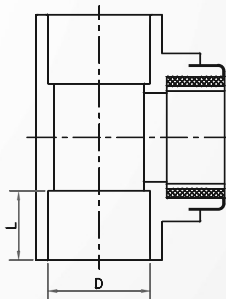

Brass Threaded Female Tee, BSP Threaded /Plain Socket

Code	Size	D	L	PN
FT0.5X0.5BI	1/2"	21.3	16.5	15
FT0.75X0.75BI	3/4"	26.7	19.5	15
FT1X1BI	1"	33.5	22.5	15

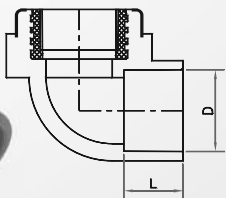

Brass Threaded Female Elbow 90°, BSP Threaded /Plain Socket

Code	Size	D	L	PN
FE0.5X0.5BI	1/2"	21.3	16.5	15
FE0.75X0.75BI	3/4"	26.7	19.5	15
FE1X1BI	1"	33.5	22.5	15



UPVC INCH SIZE PRESSURE BRASS THREADED FITTINGS

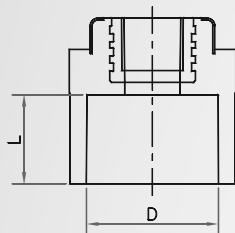

Brass Threaded Female Reducer Socket Adaptor, BSP Threaded

Code	Size	D	L	PN
FS0.75X0.5BI	3/4 x 1/2"	27.7	19.5	15

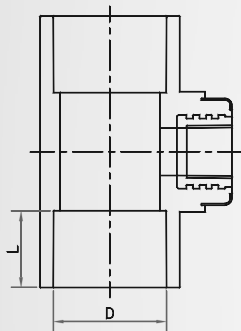

Brass Threaded Female Reducer Tee, BSP Threaded /Plain Socket

Code	Size	D	L	PN
FT0.75X0.5BI	3/4 x 1/2"	26.7	19.5	15

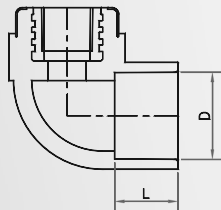

Brass Threaded Female Reducer Elbow 90°, BSP Threaded

Code	Size	D	L	PN
FE0.75X0.5BI	3/4 x 1/2"	26.7	19.5	15

UPVC INCH SIZE PRESSURE BRASS THREADED FITTINGS

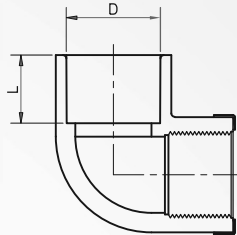

Female Socket Adaptor with Steel Reinforcing Ring, (BSP Thread / Plain Socket)

Code	Size	D	L	PN
FS0.5SR	1/2"	21.3	16.5	15
FS0.75SR	3/4"	26.7	19.5	15
FS1SR	1"	33.5	22.5	15

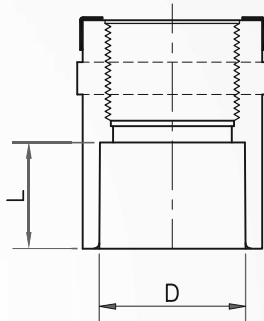

Female Tee with Steel Reinforcing Ring, (BSP Thread / Plain Socket)

Code	Size	D	L	PN
FT0.5SR	1/2"	21.3	16.5	15
FT0.75SR	3/4"	26.7	19.5	15

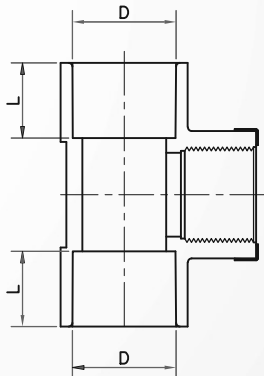

Female Elbow 90° with Steel Reinforcing Ring, (BSP Thread / Plain Socket)

Code	Size	D	L	PN
FE0.5SR	1/2"	21.3	16.5	15
FE0.75SR	3/4"	26.7	19.5	15

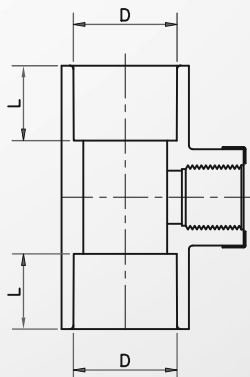

Female Reducer Tee with Steel Reinforcing Ring, (BSP Thread / Plain Socket)

Code	Size	D	L	PN
RFT0.75X0.5SR	3/4 x 1/2"	26.7	19.5	15
RFT1X0.5SR	1" 1/2"	26.7	19.5	15
RFT1.5X0.5SR	1 1/2" x 1/2"	48.2	30	15



UPVC MILLIMETER SIZE PRESSURE PIPES FITTINGS

Millimeter size Pressure Pipes : DIN 8061 / 8062

Size	Mean Outside Dia		Wall thickness		Wall thickness		Wall thickness	
			PN - 16		PN - 10		PN - 6	
	Min	Max	Min	Max	Min	Max	Min	Max
20 mm	20.0	20.2	1.5	1.9	-	-	-	-
25 mm	25.0	25.2	1.9	2.3	1.5	1.9	-	-
32 mm	32.0	32.2	2.4	2.9	1.8	2.2	-	-
40 mm	40.0	40.2	3.0	3.5	1.9	2.3	1.8	2.2
50 mm	50.0	50.2	3.7	4.3	2.4	2.9	1.8	2.2
63 mm	63.0	63.2	4.7	5.4	3.0	3.5	1.9	2.3
75 mm	75.0	75.3	5.6	6.4	3.6	4.2	2.2	2.7
90 mm	90.0	90.3	6.7	7.6	4.3	5.0	2.7	3.2
110 mm	110.0	110.30	8.2	9.3	5.3	6.1	3.2	3.8
160 mm	160.0	160.40	11.9	13.3	7.7	8.7	4.7	5.4

Pressure Pipes to ISO 161-1 Metric series

Size	Mean Outside Dia		Wall thickness		Wall thickness		Wall thickness	
			PN - 16		PN - 10		PN - 6	
	Min	Max	Min	Max	Min	Max	Min	Max
20 mm	20.0	20.2	1.2	1.6	-	-	-	-
25 mm	25.0	25.2	1.5	1.9	-	-	-	-
32 mm	32.0	32.2	1.9	2.3	-	-	-	-
40 mm	40.0	40.2	2.4	2.9	1.6	2.0	-	-
50 mm	50.0	50.2	3.0	3.6	2.0	2.5	1.3	1.7
63 mm	63.0	63.2	3.8	4.4	2.5	3.0	1.6	2.0
75 mm	75.0	75.3	4.5	5.2	2.9	3.4	1.9	2.3
90 mm	90.0	90.3	5.4	6.2	3.5	4.1	2.2	2.7
110 mm	110.0	110.3	6.6	7.5	4.2	4.9	2.7	3.2
160 mm	160.0	160.4	9.5	10.7	6.2	7.1	4.0	4.7

For Water Supply, Irrigation, Drainage mains & Duct Cabling

Available in standard length of 5.8 / 6 meters with plain ends, pushfit rubber ring (for dia > / 75mm) or solvent socket ends.

Working pressure given are based on a temperature of 20°C. UPVC Pipes derate at higher temperature.

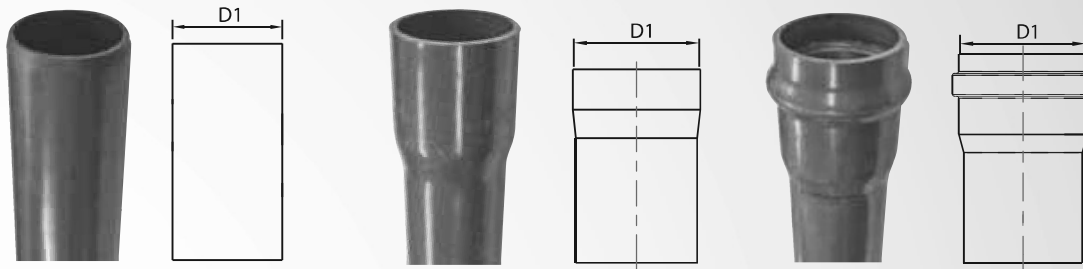

UPVC MILLIMETER SIZE PRESSURE PIPES AND FITTINGS

(DIN 8063 ; PN-16)

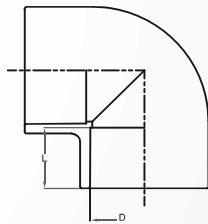

Elbow 90° Plain

Code	Size	D	L	PN
E9020	20 mm	20.1	16.0	16
E9025	25 mm	25.1	19.0	16
E9032	32 mm	32.1	22.0	16
E9040	40 mm	40.1	26.0	16
E9050	50 mm	50.1	31.0	16
E9063	63 mm	63.1	38.0	16
E9075x2.5	75 mm	75.1	44.0	16
E9090	90 mm	90.1	51.0	16
E90110(N)	110 mm	110.1	61.0	16
E90160	160 mm	160.2	86.0	16
E90200	200 mm	200.2	106.0	10

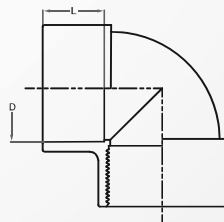

Female Elbow 90° One end plain/other end BSP female thread

Code	Size	D	L	PN
FE20X0.5	20 x 1/2"	20.1	16.0	16
FE25X0.75	25 x 3/4"	25.1	19.0	16
FE32X1	32 x 1"	32.1	22.0	16
FE40X1.25	40 x 1 1/4"	40.1	26.0	16
FE50X1.5	50 x 1 1/2"	50.1	31.0	16
FE63X2	63 x 2"	63.1	38.0	16
FE75X2.5WOC	75 x 2 1/2"	75.1	44.0	16
FE90X3WOC	90 x 3"	90.1	51.0	16



UPVC MILLIMETER SIZE PRESSURE PIPES AND FITTINGS

(DIN 8063 ; PN-16)

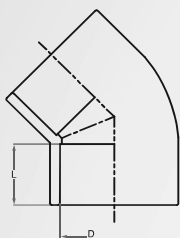

Elbow 45° Plain

Code	Size	D	L	PN
E4520	20 mm	20.1	16.0	16
E4525	25 mm	25.1	19.0	16
E4532	32 mm	32.1	22.0	16
E4540	40 mm	40.1	26.0	16
E4550	50 mm	50.1	31.0	16
E4563	63 mm	63.1	38.0	16
E4575	75 mm	75.1	44.0	16
E4590	90 mm	90.1	51.0	16
E45110	110 mm	110.1	61.0	16
E45160	160 mm	160.2	86.0	16
E45200	200 mm	200.2	106.0	10

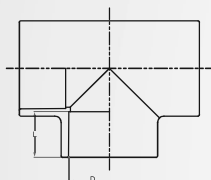

Tee 90° Plain

Code	Size	D	L	PN
T20	20 mm	20.1	16.0	16
T25	25 mm	25.1	19.0	16
T32	32 mm	32.1	22.0	16
T40	40 mm	40.1	26.0	16
T50	50 mm	50.1	31.0	16
T63	63 mm	63.1	38.0	16
T75x2.5	75 mm	75.1	44.0	16
T90	90 mm	90.1	51.0	16
T110(N)	110 mm	110.1	61.0	16
T160	160 mm	160.2	86.0	16
T200	200 mm	200.2	106.0	10

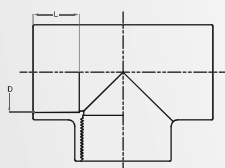

Female Tee : Two end plain/Center end BSP female thread

Code	Size	D	L	PN
FT20X0.5	20 x 1/2"	20.1	16.0	16
FT25X0.25	25 x 3/4"	25.1	19.0	16
FT32X1	32 x 1"	32.1	22.0	16
FT40X1.25	40 x 1 1/4"	40.1	26.0	16
FT50X1.5	50 x 1 1/2"	50.1	31.0	16
FT63X2	63 x 2"	63.1	38.0	16
FT75X2.5	75 x 2 1/2"	75.1	44.0	16
FT90X3	90 x 3"	90.1	51.0	16

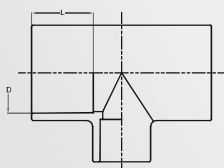

Reducing Tee

Code	Size	D	L	PN
RT25X20	25 x 20mm	25.1	19.0	16
RT32X20	32 x 20mm	32.1	22.0	16
RT32X25	32 x 25mm	32.1	22.0	16
RT50X20	50 x 20mm	50.1	31.0	16
RT50X25	50 x 25mm	50.1	31.0	16
RT50X32	50 x 32mm	50.1	31.0	16
RT63X20	63 x 20mm	63.1	38.0	16
RT63X25	63 x 25mm	63.1	38.0	16
RT63X32	63 x 32mm	63.1	38.0	16
RT63X50	63 x 50mm	63.1	38.0	16
RT90X63	90x 63mm	90.1	51.0	16
RT110X90	110 x 90mm	110.1	61.0	16
RT160X90	160 x 90mm	160.2	86.0	16
RT160X110	160 x 110mm	160.2	86.0	16

UPVC MILLIMETER SIZE PRESSURE PIPES AND FITTINGS

(DIN 8063 ; PN-16)

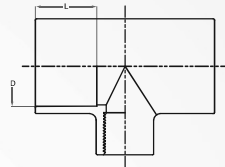

Reducing Female Tee: Two end plain/Center end BSP female thread

Code	Size	D	L	PN
RFT25X0.5	25 x 1/2"	20.1	16.0	16
RFT32X0.5	25 x 1/2"	25.1	19.0	16
RFT32X0.75	32 x 3/4"	32.1	22.0	16
RFT50X0.5	50 x 1/2"	50.1	31.0	16
RFT50X0.75	50 x 3/4"	50.1	31.0	16
RFT63X0.5	63 x 1/2"	63.1	38.0	16
RFT63X0.75	63 x 3/4"	63.1	38.0	16
RFT90X0.75	90 x 3/4"	90	51.0	16

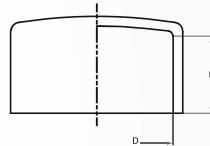
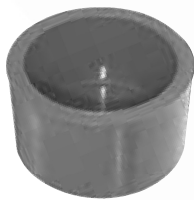

End Cap Plain

Code	Size	D	L	PN
C20	20 mm	20.1	16.0	16
C25	25 mm	25.1	19.0	16
C32	32 mm	32.1	22.0	16
C40	40 mm	40.1	26.0	16
C50	50 mm	50.1	31.0	16
C63	63 mm	63.1	38.0	16
C75x2.5	75 mm	75.1	44.0	16
C90	90 mm	90.1	51.0	16
C110	110 mm	110.1	61.0	16
C160	160 mm	160.2	86.0	16
C200	200 mm	200.2	106.0	10

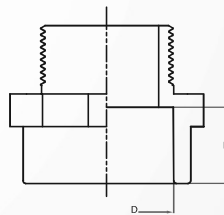

Male Thread Adaptor/Nipple Socket; BSP male thread/plain socket

Code	Size	D	L	PN
MA20X0.5	20 x 1/2"	20.1	16.0	16
MA25X0.75	25 x 3/4"	25.1	19.0	16
MA32X1	32 x 1"	32.1	22.0	16
MA40X1.25	40 x 1 1/4"	40.1	26.0	16
MA50X1.5	50 x 1 1/2"	50.1	31.0	16
MA63X2	63 x 2"	63.1	38.0	16
MA75X2.5	75 x 2 1/2"	75.1	44.0	16
MA90X3	90 x 3"	90.1	51.0	16
MA110X4	110 x 4 "	110.1	61.0	16

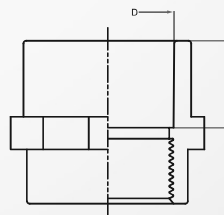

Female Socket Adaptor ; BSP female thread/plain socket

Code	Size	D	L	PN
FS20X0.5	20 x 1/2"	20.1	16.0	16
FS25X0.75	25 x 3/4"	25.1	19.0	16
FS32X1	32 x 1"	32.1	22.0	16
FS40X1.25	40 x 1 1/4"	40.1	26.0	16
FS50X1.5	50 x 1 1/2"	50.1	31.0	16
FS63X2	63 x 2"	63.1	38.0	16
FS75X2.5	75 x 2 1/2"	75.1	44.0	16
FS90X3	90 x 3"	90.1	51.0	16
FS110X4	110 x 4 "	110.1	61.0	16



UPVC MILLIMETER SIZE PRESSURE PIPES AND FITTINGS

(DIN 8063 ; PN-16)

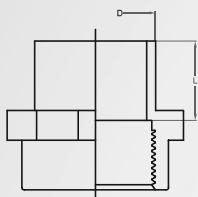

Female Slip Adaptor ; BSP female thread/male plain socket

Code	Size	D	L	PN
FSL20X0.5	20 x 1/2"	20.1	16.0	16
FSL25X0.75	25 x 3/4"	25.1	19.0	16
FSL32X1	32 x 1"	32.1	22.0	16
FSL40X1.25	40 x 1 1/4"	40.1	26.0	16
FSL50X1.5	50 x 1 1/2"	50.1	31.0	16
FSL63X2	63 x 2"	63.1	38.0	16

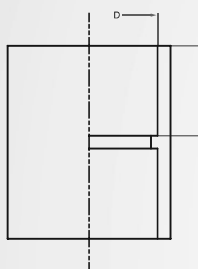

Socket

Code	Size	D	L	PN
S20	20 mm	20.1	16.0	16
S25	25 mm	25.1	19.0	16
S32	32 mm	32.1	22.0	16
S40	40 mm	40.1	26.0	16
S50	50 mm	50.1	31.0	16
S63	63 mm	63.1	38.0	16
S75x2.5	75 mm	75.1	44.0	16
S90	90 mm	90.1	51.0	16
S110	110 mm	110.1	61.0	16
S160	160 mm	160.2	86.0	16
S200	200 mm	200.2	106.0	10

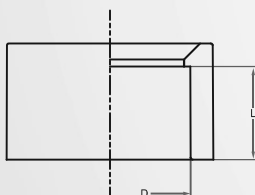
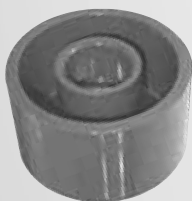

Reducer Bush

Code	Size	D	L	PN
RB25X20	25 x 20mm	25.1	19.0	16
RB32X20	32 x 20mm	32.1	22.0	16
RB32X25	32 x 25mm	32.1	22.0	16
RB40X20	40 x 20mm	40.1	26.0	16
RB40X25	40 x 25mm	40.1	26.0	16
RB40X32	40 x 32mm	40.1	26.0	16
RB50X20	50 x 20mm	50.1	31.0	16
RB50X25	50 x 25mm	50.1	31.0	16
RB50X32	50 x 32mm	50.1	31.0	16
RB63X20	63 x 20mm	63.1	38.0	16
RB63X25	63 x 25mm	63.1	38.0	16
RB63X32	63 x 32mm	63.1	38.0	16
RB63X50	63 x 50mm	63.1	38.0	16
RB75X50	75 x 50mm	75.1	44.0	16
RB75X63	75 x 63mm	75.1	44.0	16
RB90X50	90x 50mm	90.1	51.0	16
RB90X63	90x 63mm	90.1	51.0	16
RB90X75	90x 75mm	90.1	51.0	16
RB90X75	110 x90mm	110.1	61.0	16
RB110X63	110 x63mm	110.1	61.0	16
RB160X90	160 x 90mm	160.2	86.0	16
RB160X110	160 x 110mm	160.2	86.0	16
RB200X160	200 x 160mm	200.2	106.0	10
RB225X160	225 x 160mm	225.3	119.0	16

UPVC MILLIMETER SIZE PRESSURE PIPES AND FITTINGS

(DIN 8063 ; PN-16)

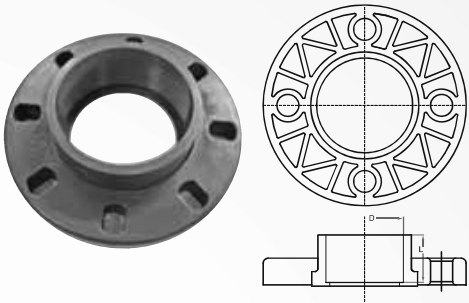

Flanges with stub				
Code	Size	D	L	PN
FL63S	63 mm	63.10	38.0	16
FL75.2.5S	75 mm	75.10	44.0	16
FL90S	90 mm	90.10	51.0	16
FL4.110S	110 mm	110.10	61.0	16
FL160S	160 mm	160.20	86.0	16
FL200S	200 mm	200.2	106.0	10

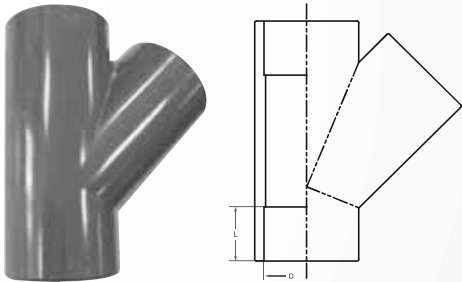

WYE 45°				
Code	Size	D	L	PN
Y25	25 mm	25.1	19.0	16
Y32	32 mm	32.1	22.0	16
Y40	40 mm	40.1	26.0	16
Y50	50 mm	50.1	31.0	16
Y63	63 mm	63.1	38.0	16

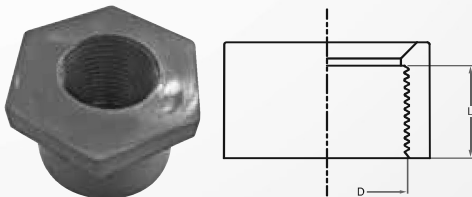

Female Reducer Bush ; BSP female thread				
Code	Size	D	L	PN
FTRRB25X0.5	25 x 1/2"	25.1	19.0	16
FTRRB32X0.5	32 x 1/2"	32.1	22.0	16
FTRRB32X0.75	32 x 3/4"	32.1	22.0	16



UPVC MILLIMETER SIZE PRESSURE PIPES AND FITTINGS

(DIN 8063 ; PN-16)

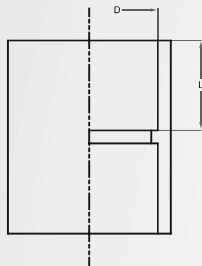

Converter Socket

Code	Size	D	L	PN
S20X0.5	20 x 1/2"	20.1 / 21.3	16.0 / 16.5	16
S25X0.75	25 x 3/4"	25.1 / 26.7	19.0 / 19.5	16
S32X1	32 x 1"	32.1 / 33.5	22.0 / 22.5	16
S50X1.5	50 x 1 1/2"	50.1 / 48.2	31.0 / 30.0	16
S63X2	63 x 2"	63.1 / 60.3	38.0 / 36.0	16
S90X3	90 x 3"	90.1 / 88.8	51.0 / 50.5	16
S110X4	110 x 4"	110.1 / 114.2	61.0 / 63.0	16

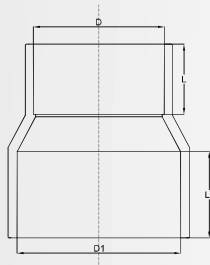

Reducing Socket

Code	Size	D1 / D	L1 / L	PN
RS200X160	200 x 160mm	200.2 / 160.2	106.0 / 86.0	10



FLOW DATA

Flow Chart for uPVC PIPES NOMINAL DIAMETER ½" TO 12"

The accompanying flow chart has been calculated on the mean bore of UPVC pipes manufactured in different classes according to PN Rating BS EN ISO1452: 2: 2000 These standards are based on pipes made to inch diameters and the diagram has been prepared on the basis of imperial units; metric equivalents of velocity and a separate scale for rate of flow in litres per second are incorporated.

The smooth bore of UPVC pipes, which are not subject to modulation, together with long pipe lengths, enables them to be treated as hydraulically smooth where they are used for the conveyance of potable water supply. Sewage pumping mains are in certain circumstances, liable to acquire coatings of limes which may reduce their flow capacity.

To use the chart it is only necessary to visually locate the appropriate intersection points to ascertain the relationship between pipe dimension, flow and loss of head and if required, the mean velocity of flow.

The charts has been prepared using the **Colebrook = white Flow equation.**

$$V = -2\sqrt{2gDi} \cdot \text{Log} \left(\frac{ks}{3.7D} \frac{2.51\vartheta}{D\sqrt{2gDi}} \right)$$

Where

- V = Velocity in metres per second
- g = gravitational acceleration (a value of 9.807 M/s has been assumed)
- i = Hydraulic gradient
- ϑ = Kinetic Viscosity (a value of 1.141×10^{-6})
- Ks = linear measure of roughness in mm. = 0.003 mm
- D = mean internal diameter of pipe (manufactured to B.S.EN ISO 1452-2:2000)

K. VALUE

The frictional losses occasioned by flow through fittings are approximately proportional to the square of the liquid velocity.

The losses can be determined by the use of the following formula.

$$H = \frac{Kv^2}{2g}$$

Where

- H = loss of head
- V = liquid velocity
- g = acceleration due to gravity
- K = coefficient dependent on type of fitting

various Values for K are:-

90° Elbow	K = 1.00
45° Elbow	K = 0.4
22 1/2° Elbow	K = 0.2
90° Bend	K = 0.2
45° Bend	K = 0.1
22 1/2° Bend	K = 0.05
90° Tee flow in line	K = 0.35
90° Tee flow in to or from ranch	K = 1.20
Gate valve: Open	K = 0.12
¼ closed	K = 1.0
½ closed	K = 6.0
¾ closed	K = 24.0
Globe valve: open	K = 10.0
Butterfly valve: open	K = 0.3



FLOW CHART FOR PVC - U PIPES

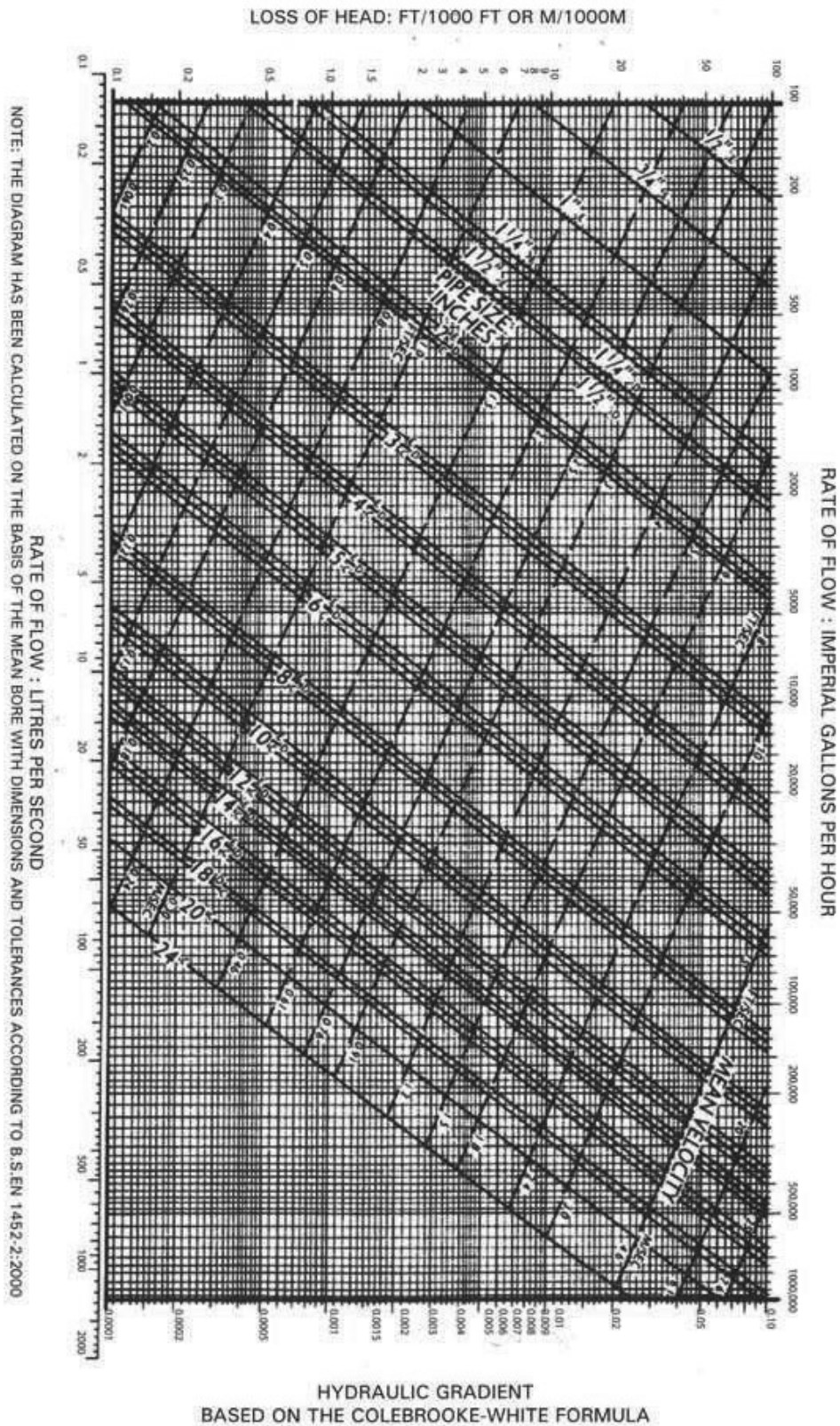

TRENCH WORK

The line and level of the pipe and hence buried depth of the pipeline, will have been predetermined at the design stage. The trench should not be excavated too far in advance of pipe laying and should be backfilled as soon as possible, **however joints should be left exposed until testing has been successfully completed.**

The width of the trench at ground level will depend on the type of subsoil and buried depth of the pipeline. The minimum width of the trench at the pipe springing line should be as narrow as practicable but not less than the pipe diameter plus 300mm. The maximum width of the trench at the crown of the pipe must not exceed the pipe diameter plus 600mm.

TRENCH FORMATION

a) DIRECT LAYING

If the pipe is to be laid directly onto the trench bottom make sure that the trench formation is composed of:-

Stable, uniform, fine-grained soil, with no large flints or stones, or other protuberances which might cause point-loading on the pipe.

When laying the pipe directly the trench formation should be trimmed to an even finish which will provide continuous support to the pipe. Additional excavation will be required at the position of the pipe sockets to ensure proper joint assembly and pipe support.

b) PIPE LAYING ON BEDDING

If the formation is unsuitable for direct laying the trench will need to be excavated to a further depth of minimum of 100 mm below the underside of the pipe

This should be made up with a suitable bedding material as below. In extreme conditions such as waterlogged or unstable ground it may be necessary to increase the thickness of the bedding material.

If guidance is required please consult our technical department. Pipelines laid through rock should always be laid on a minimum of 100mm bed of suitable bedding materials.

TRENCH WORK

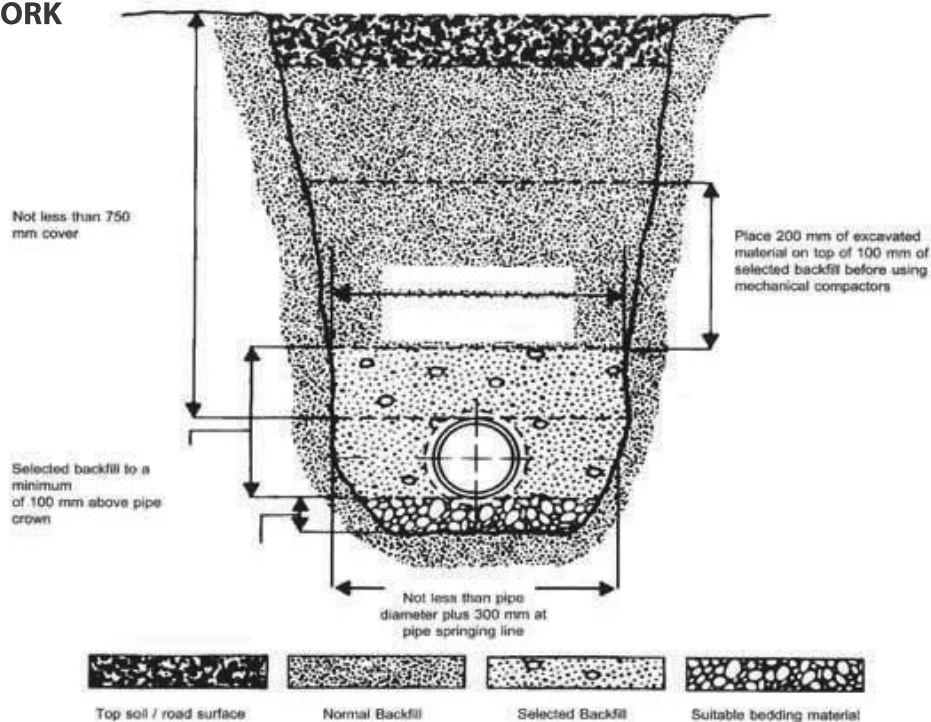



BEDDING MATERIAL

The bedding material selected may be available from excavated trench material or may need to be imported from another source. The material should be granular in nature, free from large stones, debris or frozen matter, and preferably fine grained in nature. Materials such as clay or hard chalk will break up when wetted should not be used. Suitable materials are free draining coarse sand and nominal single size gravel with rounded or angular particles. Gravels should be normal single size 10mm or 5 to 10 mm graded, preferably with angular particles which have good self compacting properties.

BACKFILL

Following satisfactory bedding and pipe laying, selected material should be placed in the trench in layers not exceeding 100 mm, each layer being thoroughly compacted by hand. The selected material should have a maximum particle size of 75mm and be free from topsoil, stones, tree roots and other debris which may be harmful to the pipe. The initial backfilling of selected material should continue to a minimum height of 100 mm above the crown of the pipe.

The bedding material should be placed carefully in the trench and properly compacted by hand to ensure a sound continuous bed for the pipes. Particular attention should be paid to the socket holes to ensure correct placement and compaction of bedding material in this area. **Bricks or other forms of temporary pipe support should never be left in the trench.**

Above this level normal backfilling procedures should be adopted including compaction to prevent subsequent settlement of the trench infill. Heavy mechanical compactors should not be used until there is a minimum 300 mm layer of material above the crown of the pipe. Any trench sheeting should be carefully withdrawn during the backfilling and infill process, to allow proper compaction to occur.



AVERAGE QUANTITIES OF SOLVENT CEMENT, CLEANER AND LUBRICANT REQUIRED FOR uPVC PIPE JOINTS USING 500ML CONTAINERS

SOLVENT CEMENT		SOLVENT CLEANER		LUBRICANT FOR UPVC PIPES WITH RING JOINTS	
Size of pipe	Qty(500ML)	Size of pipe	Qty(500ML)	Size of pipe	Qty(500ML)
1/2"	212	1/2"	141.35	0	0
3/4"	168	3/4"	112	0	0
1"	134	1"	89.35	0	0
1-1/4"	86	1-1/4"	57.35	0	0
1-1/2"	62	1-1/2"	41.35	0	0
2"	38	2"	25.35	2"	50
2-1/2"	24	2-1/2"	16	2-1/2"	0
3"	17	3"	11.35	3"	44
4"	10	4"	6.7	4"	39
5"	6.5	5"	4.35	5"	26
6"	4.5	6"	3	6"	22
7"	3.4	7"	2.3	7"	20
8"	2.6	8"	1.75	8"	16
9"	2	9"	1.35	9"	13
10"	1.7	10"	1.15	10"	11
12"	1.2	12"	0.8	12"	9

DEFLECTION

The Loc-Ring Internal Socket permits an angular deflection at the joint 2/3. The introduction of joint deflection is, however, generally unnecessary in an inherently flexible UPVC pipeline. Sufficient flexibility is provided by individual pipe lengths to enable gentle curves to be negotiated without imparting deflection at the joints. As a general guide the cold bending radius (R) of UPVC pipe length can be calculated as follows:

$$R = 250 \times \text{External Diameter}$$

Where a shorter radius of curvature is required, then uPVC formed bends must be introduced.

THERMAL MOVEMENT

Research has shown that in buried High Pressure installation, below ground temperatures remain constant and little attention need be given to the accommodation of thermal movement. It is only necessary to consider the effect of ambient temperatures during laying operations. Where solvents welded joints are being used the pipe line should be allowed to assume thermal stability after laying before final connections are made and anchor block positioned. No precautions are necessary using push-fit joints which are self connecting.

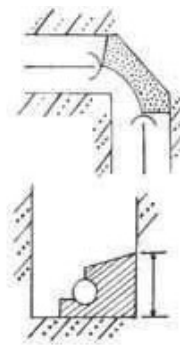

PVC BEND THRUST FORCES

When a pipeline is constructed using push-fit joint separation due to internal pressure and resulting thrust forces must be prevented. This is achieved using concrete thrust blocks at directional changes, branches, end caps, valves, etc. The design of UPVC pipes provides a safety factor of 2:1 after a life of 50 years at maximum working pressure. In designing thrust blocks it is logical to apply a similar factor of safety after calculating thrust forces on the maximum foreseeable pressure.

In view of the flexible nature of UPVC it is desirable in thrust block design to permit the largest possible area of contact between fitting concerned and the concrete blocks so that a restraint against excessive flexing as well as a thrust is provided (Fig.1). This feature, in certain soil conditions, may also be applied to solvent welded pipelines which need so support against thrust but which can benefit by flexing restraint at abrupt directional changes. Thrust blocks concrete should not be allowed to encase the fitting as the external diameter of a UPVC pipe must be left free to distend due to pressure fluctuation. The block may be designed as shown in fig.1 or if total encasement is preferred the fitting should first be wrapped in several layers of heavy gauge polythene film prior to concreting to provide freedom of movement and a barrier against abrasion.



BACK-FILLING AND CONSOLIDATION

It is good practice to arrange back-filling can progress to follow closely behind main laying. UPVC pipe can be laid with such speed that backfilling can progress simultaneously with pipe-laying.

The initial pipe back-filling should be of reasonably compatible material (compaction factor 0.3 or less) and free from sharp stones or other debris, which, on compaction can cause detrimental point loading on the pipeline. This initial backfilling should be thoroughly compacted by hand ramming.

Mechanical ramming of subsequent backfill should not commence until least 30cms. Of hand consolidated cover is attained. Where pipes have less than 76cms Of cover, consideration should always be given to the likelihood of heavy vehicular traffic loadings.

The encasement of UPVC pipe in concrete is both wasteful and destructive. It converts a tough flexible pipeline into a grid beam of limited flexural strength. At cover depths of 60cm and more, protection by normal, well compacted granular surround is generally adequate. At shallower cover depths under roads, protection is best afforded by use of concrete slabs upon a cushion of granular fill or by passing the pipeline through a protective pipe duct of greater diameter.

INSTALLATION – ABOVE GROUND

Where u PVC High Pressure mains or services are specified for above ground situations the following notes should be considered where applicable.

FROST PROTECTION

Like most materials u PVC becomes prone to impact damage as the temperature drops below zero. Pipe-runs should therefore be sited or protected in such manner as will prevent accidental damage in conditions of extreme cold.

Due to the extremely low thermal conductivity of the material it is unlikely that the contents of a u PVC pipeline will freeze in normal UK winter temperatures. However abnormal climatic conditions and periods of “no-flow” should be considered and exposed pipe work lagged accordingly.

WORKING PRESSURE

The maximum pressure ratings of u PVC pipes have been calculated on the basis that the pipeline temperature is no greater than 20° C. where the pipe temperature is likely to be exceeded then the maximum pressure rating must be reduced if the full operational life-expectancy of the pipeline is to be maintained.

It is unlikely that such modification will be necessary due to mains water temperatures, but where a watermain is in an exposed location it will be necessary to reduce the pipe pressure rating by 2% for each C by which the ambient temperature exceeds 20°C.

THERMAL MOVEMENT

Where the temperature of a u PVC pipeline is likely to vary due to atmospheric temperature it is important to plan the variations in pipeline length which may arise as a result of temperature differences.

Expansion and contraction can be calculated using the formula:

$$dL = \alpha \times L \times dt$$

Where

- dL = Change in the length in millimeters.
- α = 0.8 mm/m/°C - (PVC)
- L = Original length of pipe in meters.
- dt = Total temperature range in °C

Calculated of expansion and contraction should take account of the minimum and maximum foreseeable temperature conditions.

When the total length variation of the pipeline has been established, the positioning of both support and anchor brackets can be determined.

Anchor brackets can be so arranged to sub-divide the total length variation and to control movement in a specific direction. Support brackets must allow the pipeline to move freely. It is normally possible like correct bracket arrangements to direct movement in such a manner that this is accommodated by directional changes in the line.

Expansion bellows may be used to accommodate excessive movement but in such instance the pipes so connected must be restrained against possible separation.

Any lines valves must be firmly anchored and independently supported so that no stresses are transmitted to the pipeline.

Pipe bracket spacing for PVC-U for liquids with a density of 1 g/cm³

d	DN	Pipe brackets intervals L for SDR21 / S 10 / PN10 pipes in mm at pipe wall temperature:				
		≤20 °C	30 °C	40 °C	50 °C	60 °C
20	½	1100	1050	1000	900	700
25	¾	1200	1150	1050	950	750
32	1	1350	1300	1250	1100	900
40	1 ¼	1450	1400	1350	1250	1000
50	1 ½	1600	1550	1500	1400	1150
63	2	1800	1750	1700	1550	1300
75	2 ½	2000	1900	1850	1700	1450
90	3	2200	2100	2000	1850	1550
110	4	2400	2300	2250	2050	1750
125	-	2550	2450	2400	2200	1850
140	5	2700	2600	2500	2300	1950
160	6	2900	2800	2700	2500	2100
180	-	3100	2950	2850	2650	2200
200	-	3250	3150	3000	2800	2350
225	8	3450	3300	3200	2950	2500
250	-	3650	3500	3350	3100	2600
280	10	3750	3700	3550	3300	2750
315	12	4100	3900	3750	3500	2950
400	16	4600	4450	4250	3950	3300

For other SDR multiply the values given in the table with the following factor:
 SDR 13.6/S 6.3/PN 16 with 1.08

SDR11 /s 5/pn20 with 1.15

The pipe bracket spacing given in the table may be increased by 30% in the case of vertical pipe runs, i.e. multiply the values given by 1.3

USEFUL EQUIVALENTS

BRITISH TO METRIC		METRIC TO BRITISH	
1 inch	= 25.4 millimetres	1 millimetre	= 0.0394 inch
1 foot	= 0.3048 metre	1 metre	= 3.28 feet
1 mile	= 1.609 kilometres	1 kilometre	= 0.6214 mile
1 square mile	= 2.59 km ²	1 square kilometre	= 0.386sq.mile
1 acre	= 0.4047 hectare	1 hectare=10,000m ²	= 2.471 acre
1 cubic foot	= 28.32 litres	1 cubic metre=1000litres	= 35.31 cubic feet
1 cubic yard	= 0.76 cubic metre		= 1.31 cubic yards
1 gallon	= 4.546 litres		= 219.97 gallons
1 pound	= 0.4536 killograme	1 kilogram	= 2.205 pounds
1 m.g.d	= 0.05261m ³ /s	1 cubic metre per second	= 19.01 million gallons per day(m.g.d)
1 lbf/per square inch	= 0.07031 kgf/cm ²	1 killograme force per cm ²	= 14.223 lbf per sq.inch
1 pound force (lbf)	= 4.448 newton(N)	1 kilo newton per m ²	= 0.145lbf/in ²
1 lbf/in ²	= 6.895kN/m ²	1 tonne=1000kg=	0.984 U.K.tons
Accelaration due to gravity	= 9.807m/s ²	1 newton	= 0.2248 pound force
		1 bar=29.530 in Hg	= 14.5038lbf/in ²



TEMPERATURE CONVERSIONS

The number in the centre of the three columns will be converted from the FARENHEIT to CENTIGRADE by reading to the left and from CENTIGRADE to FARENHEIT by reading to the right.

		°C ←			→ °F						
-17.78	0	32.0	-1.11	30	86.0	15.56	60	140.0	32.2	90	194.0
-17.22	1	33.8	-0.56	31	87.8	16.1	61	141.8	32.8	90	195.8
-16.67	2	37.4	0	32	89.6	16.7	62	143.6	33.3	92	197.6
-16.11	3	37.4	0.56	33	91.4	17.2	63	145.4	33.9	93	199.4
-15.56	4	39.2	1.11	34	93.2	17.8	64	147.2	34.4	94	201.2
-15.00	5	41.0	1.67	35	95.0	18.3	65	149.0	35.0	95	203.0
-14.44	6	42.8	2.22	36	96.8	18.966	66	150.8	35.6	96	204.8
-13.89	7	44.6	2.78	37	98.6	19.467	67	152.6	36.1	97	206.6
-13.33	8	46.4	3.33	38	100.4	20.068	68	154.4	36.7	98	208.4
-12.78	9	48.2	3.89	39	102.2	20.669	69	156.2	37.2	99	210.2
-12.22	10	50.0	4.44	40	104.0	21.170	70	158.0	37.8	100	212.0
-11.67	11	51.8	5.00	41	105.8	21.771	71	159.8	40.6	105	221.0
-10.56	12	55.4	5.56	42	107.6	22.272	72	166.1	43.3	110	230.0
-11.11	13	53.6	6.11	43	109.4	22.873	73	163.4	46.1	115	239.0
-10.00	14	57.2	6.67	44	111.2	23.374	74	165.2	48.9	120	248.0
-9.44	15	59.0	7.22	45	113.0	23.975	75	167.0	51.7	125	257.0
-8.89	16	60.8	7.78	46	114.8	24.476	76	168.8	54.4	130	266.0
-8.33	17	62.6	8.33	47	116.6	25.077	77	170.6	57.2	135	275.0
-7.78	18	64.4	8.89	48	118.4	25.6	78	172.4	60.0	140	284.0
-7.22	19	66.2	9.44	49	120.2	26.1	79	174.2	62.8	145	293.0
-6.67	20	68.0	10.00	50	122.0	26.7	80	176.0	65.6	150	302.0
-6.61	21	69.8	10.56	51	123.8	27.2	81	177.8	68.3	155	311.0
-5.56	22	71.6	11.11	52	125.6	27.8	82	179.6	71.1	160	320.0
-5.00	23	73.4	11.67	53	127.4	28.3	83	181.4	73.9	165	329.0
-4.44	24	75.2	12.22	54	129.0	28.9	84	183.2	76.7	170	338.0
-3.89	25	77.0	12.78	55	131.0	23.4	85	185.0	79.4	175	347.0
-3.33	26	78.8	13.33	56	132.8	30.0	86	186.8	82.2	180	356.0
-2.78	27	80.6	13.89	57	134.6	30.6	87	188.6	85.0	185	365.0
-2.22	28	82.4	14.44	58	136.4	31.1	88	190.4	87.8	190	374.0
-1.67	29	84.2	15.00	59	138.2	31.17	89	192.2	90.6	195	383.0

HYDROSTATIC TESTING

The length of test section will be determined by practical reasons such as availability of water, or the number of pipes, fittings and joints to be tested. Long pipelines should be tested in section as main laying progresses.

The pipe length to be tested may be blanked off using a blank Iron or steel flange previously drilled and tapped for test equipment connection and strutted as necessary against end thrust. The blank flange may be attached to the pipeline by a Viking Johnson Flange Adaptor or similar.

Testing should preferably not be carried out against closed valves. All charging and testing should preferably be carried out from the lowest point of the under test section and all testing equipment should be located at this point. The pressure gauge also should be located at the lowest point or adjustment must be made for the level of the pressure gauge relative to the pipe's position.

Prior to testing, care should be taken to ensure that all anchor blocks have attained adequate maturity and that any solvent welded joints included in the pipe system have developed full strength. Correct support and anchorage of any above ground sections of the pipeline is also necessary. Underground pipelines should be back filled, taking particular care to consolidate around lengths which may have been deflected to negative curves. All joints may be left exposed until testing is completed.

With the stand pipe, valves and pressure gauge assembled, filling of the main can begin. The main should be charged slowly, preferably from the lowest point with any air cock in the "open" position. They should be closed in sequence from the lowest point only when water, visibly free from aeration, is being discharged through them. Satisfactorily charged, the main should be allowed to stand overnight to allow any residual air to "settle-out" and percolate to the pipe soffit. Re-venting is then necessary and any water deficiency should be made up.

Pressure testing can then begin by pumping slowly until the required test pressure is attained. A single or double cylinder hand pump should be used for this purpose. Mechanical pumps are not recommended unless incorporating a pre-set blow-off mechanism.

The hydrostatic testing specification will be at the discretion of the responsible engineer but should not exceed 1 1/2 times the designed working pressure of the lowest rated component in the system and time duration of 24hours. under, Hydrostatic pressure

Prior to the test, all the installed pipe line should have air release valves. Special attention must be taken to release entrapped air completely. Testing shall commence only after the calibrated pressure gauge stabilizers. Care should be taken for smaller diameter pipes and all the pipes must be visually inspected before installation.

A permissible water loss of 3 liters per kilometer of pipe per 25mm normal bore, per 3 bar of test pressure, per 24hours, may be considered reasonable.

Air testing is not recommended if, however, for practical reasons, pneumatic testing is necessary, this should be limited to a maximum pressure of 1.5 bar. Air leakage can be detected by applying soap solution to the joints or by pre-ordourising the air with Ethyl Mercaptan. This will reduce the time duration of another wise long - term pneumatic test.

During any air - pumping operations no one should be working on or near the test section and precautions should be taken to avoid heavy objects striking the main whilst under pneumatic pressure. The following notes provide a brief guide to the installation of PVC Water Mains and Services. The subject is dealt with in detail in British Standard Code of Practice CP312 Part 2 1973, available from the British Standards Institution.

INSPECTION AND TESTING

When the system has been fully installed all pipe work and fittings should be visually inspected and hydraulically tested. Joints should be exposed until hydraulic testing has been successfully completed.

VISUAL INSPECTION

The system should be visually inspected to ensure that the correct installation procedures have been followed and that the pipes and fittings are adequately supported and restrained in the prescribed manner.

HYDRAULIC TESTING

The length of the section under test will be determined by practical considerations such as availability of water 1000 metres of nominal diameter 12 pipe has a capacity of approximately 15,400 galls) and the number of joints or fittings to be tested.

a) Trust forces

During installation the pipe line should have been suitably anchored to resist thrust at changes of direction and fixed points such as branches and hydrant connections. Testing should not take place until any in-situ concrete used as anchorage has matured and attained its required strength (normally a minimum of 7 days after placing).

Similarly solvent weld joints should be allowed to stand for a minimum of 24 hours before testing at 1 ½ times working pressure is carried out. For lower test pressures allow one hour per 15 psi test pressure.

b) Charging the Mains

The test section should be isolated, where necessary, from the rest of the system. A blank end connection drilled and tapped for test equipment. Will be required and should be installed on a suitable flange face. If no flange face is not available, the blank flange can be incorporated by means of a Viking Johnson Flange Adaptor or similar fitting.

Alternatively a suitable expanding stopper may be used. The blank flange or stopper and all the other blank ends on the system should be adequately strutted to resist the thrust developed as result of the internal pressure (a normal diameter 12 pipe with an internal pressure of 9 bar/ 130.5 psi will exert a thrust of 6.3 tons).

Testing should not be carried out against closed waves.

The system should be filled from its lowest point with all air valves and control valves in the open position. Care should be taken to avoid pressure surges and to ensure that all air is expelled from the pipeline (the presence of air can seriously affect the results of pressure test operations). Air valves should be closed as filling proceeds when the air valves are seen to be discharging water free from aeration.

When fully charged, the system should be allowed to stand for a period of 24 hours with the air valves closed to allow any residual air to proclate to the pipe soffit. During this period the system can be visually examined for leakage. The system should then be revented and any water deficiency made up.

c) Pressurising

When Charging is complete the pressure test equipment should be connected to the system via the blank flange or stopper. The equipment should consist of a single or double cylinder hand pump, a pressure gauge suitably graduated and preferably calibrated before use and press hoses to connect to a water supply and the blank flange or stopper.

The system should be pressurized slowly using the hand pump until the pressure gauge indicates the required value. The test pressure will be determined by the engineer responsible but should not exceed 1 ½ times the nominal working pressure of lowest rated component of the pipe system.

The duration of the test should be not less than one hour and not greater than 24 hours during which time the system should be isolated from the test pump.

ASSESSMENT OF TEST

The test is assessed on the basis of the amount of water required to maintain the test pressure during the prescribed period. This amount of water should not exceed that calculated by the following formula:

2 Litres per kilometer of pipe, per metre of nominal bore per metre head of test pressure per 24 hours.

As specified in W.A.A. "Civil Engineering Specifications for the Water Industry"

For example, the permissible water loss for 1 kilometre to 6 diameter PN 12 pipe when tested at PN 18 (180 metres head) pressure would be $2 \times 0.16 \times 1.0 \times 180 = 57.6$ litres per 24 hours or 2.4 litres per hour.

Any defects revealed during testing and any case of failure to meet the prescribed requirements should be rectified and the system retested until a satisfactory result is obtained. It may be helpful to retest the mains in sections to assist in fault location.

GENERAL GUIDANCE NOTES

RESISTANCE TO BIOLOGICAL ATTACK/GROWTH

uPVC pipes and fittings will not deteriorate under attack from bacteria or other microorganisms and will not provide a food source to micro- organisms, macro-organisms and fungi. Recent research has shown that certain elastomeric sealing rubbers can be susceptible to the support of microbiological growth. The water industry has specified that elastomers for use as sealing rings in potable water pipes should not be capable of supporting microbiological growth.

RESISTANCE TO WEATHERING

It is well know that thermoplastic materials may be affected by prolonged exposure to high levels of solar radiation. Exposure to sunlight for prolonged periods has two effects on uPVC pipes and fittings.

a) Surface Degradation: caused by high levels of ultra violet radiation, which manifests itself as discolouration and crazing of the surface of the uPVC.

b) Solar Gain: surface temperature of the uPVC pipes and fittings can reach as high as 16°C above the ambient temperatures in areas such as the Middle East.

Surface degradation of uPVC pipes and fittings causes a slight deterioration in the impact properties in addition to the colour changes. To protect the uPVC pipes from UV degradation, two coats of Emulsion type paint (water based), preferably white colour applied to the pipe work. All pipes and fittings must be cleaned



hand de-greased with pipe cleaner and the surface should be toughened slightly with fine emery paper, to allow paint to adhere.

However, research has shown that this and other properties such as hydrostatic burst strength, tensile strength and resistance to negative pressure are still above the British Standard requirements even after prolonged periods of exposure.

Solar gain due to exposure to direct or indirect sunlight can raise the surface temperature of pipes and fittings and this can lead to problems of ovalisation and longitudinal bending during storage.

However these effects can be avoided if the pipes and fittings are properly stored. Please refer to page no. 7 for recommendations on storage and handling.

RESISTANCE TO ABRASION & TUBERCULATION

uPVC pipes have excellent abrasion resistance properties. The nature of uPVC is such that the material gradually erodes over a large area, localized pitting does not occur.

Comparisons are difficult because of the variations occurring according to the abrasive fluid and number of cycles. However, in tests using the same percentage concentration and duration time, uPVC pipes exhibited an abrasive resistance some 2.5 times greater than mild steel.

uPVC pipe is not subject to the effects of tuberculation caused by corrosion by-products. Soluble encrustants, such as calcium carbonate, do not precipitate onto the walls of uPVC pipes.

INSITU BENDING

GENERAL

One of the practical features of uPVC pipes is their ability to bend when cold. The benefits of this cold bending property can be utilized during installation and when the pipe is in service. During installation pipes can be cold bent as a means of overcoming certain topographical or man-made obstructions without recourse to the use of purpose made bends.

During service the pipe has an inbuilt ability to take up ground movements caused by subsidence or differential settlement without undue stresses being incurred in the pipe wall.

PRACTICAL CONSIDERATIONS

It can be shown that as the pipe diameter increases the force required to affect the bending radius quoted increases.

The force required can place practical limitations on the maximum pipe diameter considered suitable for bending during installation. CP312: part 2: 1973 refers to a limiting size of nominal diameter 6.

For larger diameters the decision to attempt cold bending will depend upon available resources, site conditions and ambient temperatures. The following points must be considered in all cases:

- (a) Cold bending should not be attempted at ambient temperatures less than 5°C
- (b) The trailing socket must be securely fixed in position before the pipe is bent.
- (c) On no account must the trailing socket be subject to angular deflection and hence additional stresses.

(d) Bending should be carried out manually wherever possible.

(e) If mechanical pulling devices are used the pipe must be adequately protected from damage. Metal chains, stings, hooks or straps must not come into direct contact with the pipe.

(f) The pipe must be securely fixed in its, radiused position before laying proceeds. uPVC pipe has a "memory" and will re straighten itself if it is not secured.

(g) Every precaution shall be taken during the drawing operation to ensure the safety of site personnel.

EXPANSION AND CONTRACTION

In common with a number of engineering materials, unplasticized PVC will expand and/or contract under the influence of various in pipe and ambient temperatures. The Coefficient of Thermal Expansion Contraction of uPVC pipes which is equal to 6.0×10^{-5} per C is relatively high compared with another materials. Due count should be taken of possible expansion or contraction when installing uPVC pipes which will be subjected to variations in temperature either immediately following installation or in their service life time.

EXPANSION AND CONTRACTION ALLOWANCE

The length by which a particular length of uPVC pipe will expand or contract under a given variation in temperature is given by:

If the installation is made up of pipes with Loc Ring Integral Sockets the expansion/contraction can normally be accommodated within the socket without recourse to special fittings or pipe arrangements.

In above ground installations the solvent weld, jointing system is normally adopted and in this case special provisions will need to be made to accommodate movement resulting "from" expansion or contraction.

Please consult our Technical Department in these cases.

EXTERNAL COMPRESSIVE LOADS

SOIL AND TRAFFIC LOADS

Under normal operating conditions it is not necessary to confirm the performance of a uPVC pressure pipe for resistance to soil and traffic loadings.

In these conditions the stress resulting from the internal pressure greatly outweighs the soil and traffic load stresses.

However, in certain circumstances where mains are expected to stand empty for long periods of time, engineers may wish to confirm the structural capabilities of the pipe system under soil and traffic load conditions.

Please consult the MPI Technical Department for further information.

THRUST RESTRAINT

A uPVC pipeline operating under internal pressure will generate thrust forces at any change of direction, reduction in diameter, blank end or closed valve.

Allowance should be made to accommodate the thrust forces developed which would otherwise cause deflection, extension or joint separation in the pipeline.

It is most important that the thrust forces are calculated using the maximum internal pressure to which the pipeline is likely to be subjected.

This in the majority of cases, is the site inspection test pressure (usually 1½ times the working pressure).

In above ground installations purpose made struts or fixed brackets will be required to design resist the developed thrust modified by an appropriate factor of safety.

In below ground installation the normal method used for thrust resistance is to construct an anchor block at the point at which the thrust is developed.

The purpose of the anchor block is to transfer the thrust load to the surrounding ground and the decision on load bearing capabilities of the ground must be made at the design stage.

This will depend on the nature of the surrounding ground and will determine the dimensions of the thrust block required to resist the calculated thrust force.

When partially or completely surrounding uPVC pipes or fittings in concrete the pipe or fitting should be wrapped in heavy gauge polyethylene sheet which allow the pipe to decent slightly under the action of internal pressure and avoid stress concentration at the rigid/ flexible interface.

PIPE SUPPORT

In many non-buried situations the need arise to provide pipe supports to ensure that the weight of the pipe and its contents are adequately supported.

The recommended maximum support spacing given are for uPVC pressure pipes operating under the following conditions:-

1. Contents density 1 g/cc
2. Operating pressure PN 9
3. Horizontal pipe runs.

Change in length and flexible sections

Introduction

General

Thermoplastics are subject to greater thermal expansion and contraction than metals. Pipes installed above ground, against walls or in ducts, especially those exposed to temperature variations, require changes in length to be taken up in order to prevent extra strain on the pipes. Length changes can be taken up by:

- a) Flexible sections
- b) Compensators

Flexible sections are the most common solution, being the simplest and the most economical. The calculations for and the positioning of flexible sections are therefore described in detail.

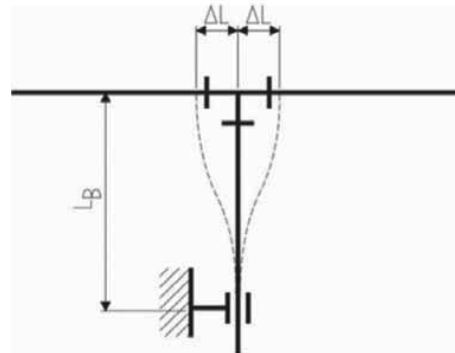
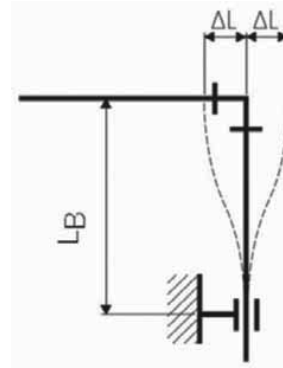

Fundamentals

The low modulus of elasticity of thermoplastics allows changes in length to be taken up by special pipe sections, where pipe supports are positioned so that they can take advantage of the natural flexibility of the material. The length of such sections is determined by the diameter of the pipeline and the extent of the thermal expansion to be compensated. Flexible sections arise naturally at any branching or change in direction of the pipeline. The movement LB of the flexible section as a result of a change L in the length must not be restrained by fixed pipe brackets, protrusions wall, girders or the like.

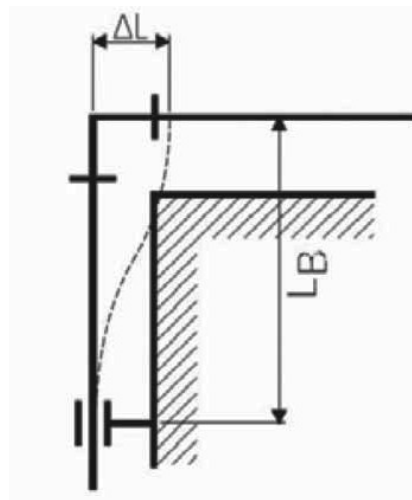

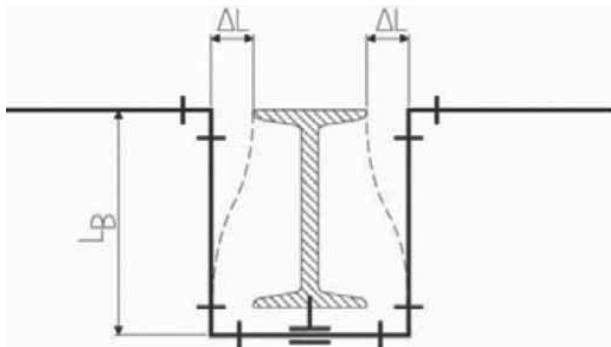

Calculation of change in length

The change in length caused by temperature can be calculated using the following formula:

$$\Delta L = L \Delta T \alpha$$

with:

- ΔL = temperature-related change in length (mm)
- L = length of the pipe section (m)
- ΔT = difference of temperature (K)
- α = coefficient of linear expansion (mm / m K)

Installation of metric industrial piping systems
Change in length and flexible sections

Coefficients of linear expansion of polymers:

Material	α in mm/m K
PVC-U	0.08 - 0.07

Tip : If the operating temperature is higher than the installation temperature, then the pipe expands. If, on the other hand, the operating temperature is lower than the installation temperature, then the pipe contracts in length.

The installation temperature must therefore be incorporated into the calculations as well as the maximum and minimum operating temperatures.

It is preferable to use "+" to indicate expansion of the pipe and "-" to indicate contraction.

The larger change in length is the one to be used for determining the required length of the flexible section.



Calculating of length of the flexible section

The required length of the flexible section can be calculated using the following formula:

$$L_B = \sqrt{\frac{3 d_a \Delta L E_{cm}}{\sigma_b}}$$

with:

- d_a = pipe outside diameter (mm)
- ΔL = change in length (mm)
- E_{cm} = average bending creep modulus for t = 25 a (N/mm²)
- b = permitted bending stress for t = 25a (N/mm²)

Remark : Because E_{cm} and b are depending on time, temperature and stress, the calculation of L_B is very difficult. Therefore the following diagrams should be used instead of the formula.

Boundary conditions for using the diagram

For easy determination of the required length of flexible section please use the following diagrams. Please take into account the given boundary conditions.

- Assembly temperature T_M = 20 °C
- T_B Operating temperature
- ΔT = T_B - T_M
- allowable bending stress 15 % of v
- PN 16.. 6
- Coefficient of friction of the pipe in the loose brackets 0.5

Information:

The following diagrams show the required flexible sections for strait pipe lengths of 10 m or 70 m. Exceeding the maximally permissible straight pipe distance would lead to buckling of the pipe due to the too large friction in the pipe clamps. Therefore the maximally possible pipe length is to consider depending on the pipe diameter =>above the hatched range.

Example: Determining the required flexible section

Calculating the relevant change in length

The example of an ABS process pipe serves to illustrate the procedure:

Length of piping from the fixed point to the branch point where the change in length is to be taken up:

- L = 8 m.
- Installation temperature: T_M = 20 °C
- Max. working temperature: T₃₅ = 1 °C
- Min. working temperature: T₂₀₋ = 2 °C

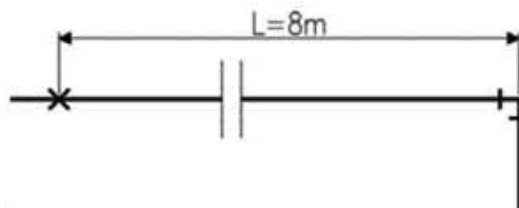

PRESSURE EQUIVALENTS TABLE

BAR	ibf/in ²	FEET HEAD	Kg/cm ²	METRES HEAD
0.1	1.45	3.35	0.1	1.02
0.2	2.9	6.69	0.2	2.04
0.3	4.35	10.04	0.31	3.06
0.4	5.8	13.38	0.41	4.08
0.5	7.25	16.73	0.51	5.10
0.6	8.7	20.07	0.61	6.12
0.7	10.15	23.42	0.71	7.22
0.8	11.6	26.76	0.82	8.16
0.9	13.05	30.11	0.92	9.18
1.0	14.5	33.46	1.02	10.2
1.1	15.95	36.8	1.12	11.22
1.2	17.4	40.15	1.22	12.24
1.3	18.86	43.49	1.33	13.26
1.4	20.31	46.84	1.43	14.82
1.5	21.76	50.18	1.53	15.3
1.6	23.21	53.53	1.63	16.35
1.7	24.66	56.87	1.73	17.34
1.8	26.11	60.22	1.84	18.36
1.9	27.56	63.57	1.94	19.37
2.0	29.01	66.91	2.04	20.39
2.1	30.46	70.26	2.14	21.41
2.2	31.91	73.60	2.24	22.43
2.3	33.36	76.95	2.35	23.45
2.4	34.81	80.29	2.45	24.47
2.5	36.26	83.64	2.55	25.49
2.6	37.71	86.98	2.65	26.51
2.7	39.16	90.33	2.75	27.53
2.8	40.61	93.68	2.86	28.55
2.9	42.06	97.02	2.96	29.57
3.0	43.51	100.37	3.06	30.59
3.1	44.96	103.71	3.16	31.61
3.2	46.41	107.06	3.26	32.63
3.3	47.86	110.40	3.37	33.65
3.4	49.31	113.75	3.47	34.67
3.5	50.76	117.09	3.57	35.69
3.6	52.21	120.44	3.67	36.71
3.7	53.66	123.79	3.77	37.73
3.8	55.11	127.13	3.88	38.75
3.9	56.56	130.48	3.98	39.77
4.0	58.02	133.82	4.08	40.79
4.1	59.47	137.17	4.18	41.81
4.2	60.92	140.51	4.28	42.83
4.3	62.37	143.86	4.38	43.85
4.4	63.82	147.2	4.49	44.87
4.5	65.27	150.55	4.59	45.89
4.6	66.72	153.90	4.69	46.91
4.7	68.17	157.24	4.79	47.93
4.8	69.62	160.59	4.89	48.95
4.9	71.07	163.93	5.00	49.97
5.0	72.52	167.28	5.10	50.99
5.1	73.97	170.62	5.20	52.01
5.2	75.42	173.97	5.30	53.03
5.3	76.87	177.31	5.40	54.05
5.4	78.32	180.66	5.51	55.07
5.5	79.77	184.01	5.61	56.08
5.6	81.22	187.35	5.71	57.10
5.7	82.67	190.70	5.81	58.12
5.8	84.12	194.04	5.91	59.14
5.9	85.57	197.39	6.02	60.16
6.0	87.02	200.73	6.12	61.18
6.1	88.47	204.08	6.22	62.20
6.2	89.92	207.42	6.32	63.22
6.3	91.37	210.77	6.42	64.24
6.4	92.82	214.12	6.53	65.26
6.5	94.27	217.46	6.63	66.28
6.6	95.73	220.81	6.73	67.30
6.7	97.18	224.15	6.83	68.32
6.8	98.63	227.50	6.93	69.34
6.9	100.08	230.84	7.04	70.36
7.0	101.53	234.19	7.14	71.38
7.1	102.98	237.53	7.24	72.40
7.2	104.43	240.88	7.34	73.42
7.3	105.88	244.23	7.44	74.44
7.4	107.33	247.57	7.55	75.46
7.5	108.78	250.92	7.65	76.48

BAR	ibf/in	FEET HEAD	Kg/cm	METRES HEAD
7.6	110.23	254.26	7.75	77.50
7.7	111.68	257.61	7.85	78.52
7.8	113.13	260.95	7.95	79.54
7.9	114.58	264.3	8.06	80.56
8	116.03	267.64	8.16	81.58
8.1	117.48	270.99	8.26	82.60
8.2	118.93	274.33	8.36	83.62
8.3	120.38	277.68	8.46	84.64
8.4	121.83	281.03	8.57	85.66
8.5	123.28	284.37	8.67	86.68
8.6	124.73	287.72	8.77	87.70
8.7	126.18	291.06	8.87	88.72
8.8	127.63	294.41	8.97	89.74
8.9	129.08	297.75	9.08	90.76
9.0	130.53	301.1	9.18	91.78
9.1	131.98	304.44	9.28	92.79
9.2	133.43	307.79	9.38	93.81
9.3	134.89	311.14	9.48	94.83
9.4	136.34	314.48	9.59	95.85
9.5	137.79	317.83	9.69	96.87
9.6	139.24	321.17	9.79	97.89
9.7	140.69	324.52	9.89	98.91
9.8	142.14	327.86	9.99	99.93
9.9	143.59	331.21	10.10	100.95
10.0	145.04	334.55	10.20	101.97
10.1	146.49	337.9	10.30	102.99
10.2	147.94	341.25	10.40	104.01
10.3	149.39	344.59	10.50	105.03
10.4	150.84	347.94	10.61	106.05
10.5	152.29	351.28	10.71	107.07
10.6	153.74	354.63	10.81	108.09
10.7	155.19	357.97	10.91	109.11
10.8	156.64	361.32	11.01	110.13
10.9	158.09	364.66	11.12	111.15
11.0	159.54	368.01	11.22	112.17
11.1	160.99	371.36	11.32	113.19
11.2	162.44	374.7	11.42	114.21
11.3	163.89	378.05	11.52	115.23
11.4	165.34	381.39	11.63	116.25
11.5	166.79	384.74	11.73	117.27
11.6	168.24	388.08	11.83	118.29
11.7	169.69	391.43	11.93	119.31
11.8	171.14	394.77	12.03	120.33
11.9	172.6	398.12	12.14	121.35
12.0	174.05	401.47	12.24	122.37
12.1	175.5	404.81	12.34	123.39
12.2	176.95	408.16	12.44	124.41
12.3	178.4	411.5	12.54	125.43
12.4	179.85	414.85	12.65	126.45
12.5	181.3	418.19	12.75	127.47
12.6	182.75	421.54	12.85	128.49
12.7	184.2	424.88	12.95	129.51
12.8	185.65	428.23	13.05	130.53
12.9	187.1	431.58	13.15	131.55
13.0	188.55	434.92	13.26	132.57
13.1	190.0	438.27	13.36	133.59
13.2	191.45	441.61	13.46	134.61
13.3	192.9	444.96	13.56	135.63
13.4	194.35	448.3	13.66	136.65
13.5	195.8	451.65	13.77	137.67
13.6	197.25	455.00	13.87	138.69
13.7	198.70	458.34	13.97	139.71
13.8	200.15	461.69	14.07	140.73
13.9	201.60	465.03	14.17	141.75
14.0	203.05	468.38	14.28	142.77
14.1	204.50	471.72	14.38	143.79
14.2	205.95	475.07	14.48	144.81
14.3	207.40	478.41	14.58	145.83
14.4	208.85	481.76	14.68	146.85
14.5	210.31	485.10	14.79	147.87
14.6	211.76	488.45	14.89	148.89
14.7	213.21	491.80	15.00	149.91
14.8	214.66	495.14	15.09	150.93
14.9	216.11	498.49	15.19	151.95
15.0	217.56	501.83	15.30	152.97

MATERIAL PROPERTIES OF UPVC

PVC pipes and fittings exhibit excellent resistance to aggressive environments, both naturally occurring and as a result of industrial activity.

RESISTANCE TO CORROSION

uPVC pipes and fittings are resistant to almost all type of corrosion, whether chemical or electrochemical in nature. Since uPVC is a non conductor, galvanic and electro chemical effects do not occur in uPVC pipe systems.

Because it is non metallic, the material is totally resistant to all forms of metallic corrosion. Aggressive waters resulting from both high sulphate soils and low hardness waters will not attach u PVC in any way.

uPVC pipes and fittings can also be considered resistant to a wide range of industrial waters and chemicals and can offer advantages in long term system life and maintenance costs.

CHEMICAL RESISTANCE

The resistance uPVC pipes and fittings to the chemical agents listed below has been drawn from CP312: Part 1: 1973 'General Principles and Choice of Materials'.

Ratings for the EPDM seals used in the High Pressure System have been Included, where the uPVC rating differs from the EPDM rating or where further information on chemicals not listed here is required, refer to the MPI Technical Department.



CHEMICAL RESISTANCE TABLE

Medium Name	CONCENTRATION	rating u PVC	@20°C EPDM
Acetaldehyde	Technically pure 40% Aqueous solution	- o	+ o
Acetic Acid	Technically Pure Glacial 40% Aqueous 10% Aqueous	o o +	+ o +
Acetic Acid Anhydride	Technically pure	-	+
Acetone	Technically pure Up To 10% Aqueous	- -	+ o
Acrylic Ester	Technically pure	-	o
Acrylonitrile	Technically pure	-	o
ADIPIC Acid	Technically Aqueous	+	+
Alcoholic Spirits (Gin, Whisky Etc.)	(approx 40 % Ethyl Alcohol)	+	o
Aluminium Chloride	10% Acqueous Saturates Acqueous	+ +	+ +
Aluminium Sulphate	10% Acqueous Cold Saturates Acqueous	+ +	+ +
Ammonia	Gaseous Technically pure	+	+
Ammonium Acetate	Aqueous all	+	c
Ammonium Carbonate	50% Aqueous	+	+
Ammonium Chloride	Aqueous 10% Acqueous Cold Saturated	+ +	+ +
Ammonium Hydrogen Fluoride	50 % Aqueous	+	+
Ammonium Hydroxide	Acqueous Cold Saturated	+	+
Ammonium Nitrate	Technically pure 40% Aqueous solution	+ +	+ +
Ammonium Phosphate	Aqueous all	+	+
Ammonium Sulphate	10% Aqueous Acqueous Saturated	+ +	+ +
Ammonium Sulphide	Aqueous All	+	+
Amyl Acetate	Technically pure	-	+
Amyl Alcohol	Technically pure	+	+
Aniline	Technically pure	-	o
Aniline Hydrochloride	Acqueous Saturated	+	o
Antimony Trichloride	90% Aqueous	+	+
Aqua Regia		+	c
Arsenic Acid	80% Aqueous	+	+
Barium Hydroxide	Acqueous Saturated	+	+
Barium Salts	Aqueous All	+	c
Beef Tallow Emulsion Sulphonated	Usual Commercial	+	c
Beer	Usual Commercial	+	+
Benzaldehyde	Saturated Acqueous	-	+
Benzene	Technically pure	+	c
Benzine	Free of lead and aromatic compounds	+	c
Benzoic Acid	All Aqueous	+	+
Benzyl Alcohol	Technically pure	o	o
Bleaching Dye	12.5% active chlorine Aqueous	+	+
Borax	All Aqueous	+	+
Boric Acid	All Aqueous	+	+
Brandy	Usual Commercial	+	+
Brine, Sea Water		+	+
Bromine Liquid	Technically pure	-	c

KEY + Recommended o Conditionally Recommended
- Not Recommended c Consult MPI Tech Service Dept.

Medium Name	CONCENTRATION	rating u PVC	@20°C EPDM
Bromine Vapours	High	-	c
Bromine Water	Saturated Aqueous	+	c
Butadiene		+	c
Butane	Technically pure	+	c
Butanol	Technically pure	+	
Butyl Acetate	Technically pure	-	
Butyl Phenol	Technically pure	o	c
Butylene Glycol	Technically pure	+	
Butylene Liquid	Technically pure	+	c
Butynediol	Aqueous 10%	+	c
Butyric Acid	Technically pure	+	c
Calcium Chloride	Saturated Aqueous all	+	+
Calcium Hydroxide	Aqueous Saturated	+	+
Calcium Hypochloride	Cold Saturated Aqueous	+	+
Calcium Nitrate	50% Aqueous	+	+
Carbon Dioxide (Carbonic acid)	Technically pure anhydrous technically pure moist	+ +	+ +
Carbon Disulphide	Technically pure	-	c
Carbon Tetrachloride	Technically pure	-	-
Caustic Potash Solution	50% Aqueous	+	+
Caustic Soda Solution	upto 10% Aqueous upto 40% Aqueous 50% Aqueous	+ + +	+ + +
Caustrial Hydrate	Technically pure	-	c
Chorethanol	Technically pure	-	c
Chloric Acid	10% Aqueous 20% Aqueous	+ +	c c
Chlorine	Moist 90% gaseous anhydrous tech. pure Liquid, tech.pure	o o -	+ + o
Chlorine Water	Saturated	o	o
Chloroacetic Acid Mono	Technically pure 50% Aqueous	+ +	+ +
Chlorobenzene	Technically pure	-	c
Chloroform	Technically pure	-	-
Chloro Methane (Methyl Cholride)	Technically pure	-	-
Chlorosulphonic Acid	Technically pure	o	c
Chrome Alum	Cold Saturated Aqueous	+	+
Chromic Acid	up to 50% Aqueous All Aqueous	+ +	c c
Chromic Acid +Sulphuric Acid +Water	50 g 15 g 35 g	+	c
Cider		+	+
Citric Acid	10% Aqueous	+	+
Clophenes	Technically pure	-	c
Coal Gas (Benzene Free)		+	c
Coconut Fat Alcohol	Technically pure	+	c
Coconut Oil	Technically pure	+	+
Compressed Air Containing Oil		o	o
Copper Salts	All Aqueous	+	+
Corn Oil	Technically pure	o	c

Medium Name	CONCENTRATION	rating u PVC	@20°C EPDM
Cresol	up to 90% aqueous	o	c
Crotonic Aldehyde	Technically pure	-	c
Cyclohexane	Technically pure	-	-
Cyclohexanol	Technically pure	+	+
Cyclohexanone	Technically pure	-	o
Densodrine W		+	c
Detergents	for usual washing lathers	+	+
Dextrine (Strach Gum)	usual commercial	+	c
Dibutyl Ether	Technically pure	-	-
Dibutyl Phthalate	Technically pure	-	+
Dibutyl Sebacate	Technically pure	-	-
Dichloroacetic Acid	Technically pure 50% Aqueous	+	+
Dichlorobenzene	Technically pure	-	-
Dichlorethylene	Technically pure	-	-
Diesel Oil		+	+
Diethylamine	Technically pure	o	c
Diglycolic Acid	30% aqueous	+	+
Di-Isobutyl Ketone	Technically pure	-	c
Dimethyl Formamide	Technically pure	-	o
Dimethylamine	Technically pure	o	-
Dinonyl Phthalate	Technically pure	-	-
Dioctyl Phthalate	Technically pure	-	-
Dioxone	Technically pure	-	+
Ethyl Acetate	Technically pure	-	+
Ethyl Alcohol	Technically pure 96%	+	+
Ethyl Alcohol + Acetic Acid		+	+
Ethyl Benzene	Technically pure	-	-
Ethyl Chloride	Technically pure	-	+
Ethyl Ether	Technically pure	-	o
Ethylene Chloride	Technically pure	-	c
Ethylene Diamine	Technically pure	o	c
Ethylene Glycol	Technically pure	+	+
Ethylene Oxide	Technically pure Liquid	-	c
Fatty Acids	Technically pure	+	+
Fatty Alcohol Sulphonate	aquaous	+	+
Fertilizers Salts	aquaous	+	+
Flourine	Technically pure	o	o
Flousilicic Acid	32% aqueous	+	+
Formaldehyde	40% aqueous	+	+
Formamide	Technically pure	-	c
Formic Acid	upto 50% aqueous techically pure	+	+
Frigen 12 (Freon 12)	Technically pure	+	+
Fruit Juices		+	+
Fruit Pulp		+	+
Fuel Oil		+	c
Furfury Alcohol	Technically pure		
Gelatine	all aqueous	+	+
Glucose	all aqueous	+	+

Medium Name	CONCENTRATION	rating u PVC	@20°C EPDM
Glycerine	Technically pure all aqueous	+	+
Glycocoll (Glycin)	10% aqueous	+	c
Glycolic Acid	37% aqueous	+	o
Heptane	Technically pure	+	c
Hexane	Technically pure	+	c
Hydrazine Hydrate	aqueous	+	c
Hydrobromic Acid	aqueous 50%		
Hydrochloric Acid	5% aqueous 10% aqueous upto 30 % aqueous 36% aqueous	+	+
Hydrocyanic Acid	Technically pure	+	+
Hydrofluoric Acid	70% aqueous 50% aqueous, upto 40 % aqueous,	+	o
Hydrogen	Technically pure	+	+
Hydrogen Chloride	Technically pure, gaseous	+	c
Hydrogen Peroxide	10% aqueous 30% aqueous	+	+
Hydrogen Sulphide	techincally pure saturated aqueous	+	+
Hydroxilamine Sulphate	all aqueous	+	c
Iodine Solution	65% iodine in ethonol	-	o
Iron Salts	all aqueous	+	+
Iso-Octane	Technically pure	+	+
Isoprophyl Alcohol	Technically pure	+	+
Isoprophyl Ether	Technically pure	-	c
Lactic Acid	10% aqueous	+	+
Lanolin	Technically pure	+	c
Lead Acetate	aqueous saturated	+	+
Linseed Oil	Technically pure	+	c
Liquers		+	c
Lubricating Oil		+	c
Lubricating Oil Free Of Aromatic Compounds		+	c
Magnesium Salts	all aqueous	+	+
Maleic Acid Malic Acid	cold saturated aqueous 1% aqueous	+	c
Marmalade		+	+
Mercury	pure	+	+
Mercury Salts	cold saturated aqueous	+	+
Methane	Technically pure	+	c
Methanol	all	+	+
Methyl Acetate	Technically pure	-	c
Methyl Amine	32% acqeous	o	c
Methyl Bromide	Technically pure	-	c
Methyl Chloride	Technically pure	-	c
Methyl Ethyl Ketone	Technically pure	-	+
Methyl Chloride	Technically pure	-	c
Milk		+	+
Mineral Water		+	+

KEY + Recommended o Conditionally Recommended
- Not Recommended c Consult MPI Tech Service Dept.



Medium Name	CONCENTRATION	rating u PVC	@20°C EPDM
Mixed Acid (I) Sulphuric Nitric Water	48%	+	+
	49%		
	3%		
	50%	+	+
	31%		
	19%		
	10%	+	+
	20%		
	70%		
Mixed Acid (I) Sulphuric Nitric Water	3 parts 1 part 2 parts	o	o
Mixed Acid (I) Sulphuric Nitric Water	30% 60% 10%	+	+
Molasses		+	+
Molasses Wort		+	+
Monochloroacetic Acid Ethyl Ester	technically pure	o	c
Monochloroacetic Acid Methyl Ester	technically pure	o	c
Morphalin	technically pure	-	c
Mowilith D	usual commercial	+	c
Naphthalene	technically pure	-	c
Nickel Salts	cold saturated aqueous	+	+
Nitric Acid	6.3% aqueous	+	+
	upto 40% aqueous	+	+
	65% aqueous	o	o
	100%	-	c
Nitrobenzene	technically pure	-	c
Nitrotoluene	technically pure	o	c
Nitrous Gases	low, wet & dry	+	c
Oleic Acid	technically pure	+	o
Oleum	10% SO3	+	c
Oleum Vapours	traces	+	c
Olive Oil		+	c
Oxalic Acid	cold saturated aqueous	+	+
Oxygen	all	+	+
Ozone	up to 2% in air	+	+
	cold saturated aqueous	+	+
Palm Oil, Palm Net Oil		+	c
Paraffin Emulsions	usual commercial aqueous	+	c
Parrafin Oil		+	c
Perchloric Acid	10% aqueous	+	c
	70% aqueous	o	c
Perchloroethylene	technically pure	-	c
Petroleum	technically pure	+	c
Petroleum Ether	technically pure	+	c
Petroleum Jelly	technically pure	o	c
Phenol (Carbolic Acid)	up to 10% aqueous	+	c
	up to 90% aqueous	o	c
Phenylhydrazine	technically pure	-	c
Phenylhydrazine Hydrochloride	aqueous	o	c
Phosgene	liquid technically pure	-	c
	gaseous technically pure	+	c

Medium Name	CONCENTRATION	rating u PVC	@20°C EPDM
Phosphoric Acid	up to 30% aqueous	+	c
	50% aqueous	+	c
	85% aqueous	+	c
Phosphorous Chlorides		-	-
Phosphorous Trichlorides		c	c
Phosphorous Pentachloride		c	
Phosphorous Oxychloride	technically pure	-	+
Phosphorous Pentoxide	technically pure	+	c
Photographic Developer	usual commercial	+	c
Photographic Emulsion		+	c
Photographic Fixer	usual commercial	+	c
Phthalic Acid	saturated aqueous	+	c
Picric Acid	1% aqueous	+	c
Potash(Potassium Carbonate)	cold saturated aqueous	+	+
Potassium / Aluminium Sulphates (Alum)	50% aqueous	+	+
Potassium Bichromate	saturated aqueous	+	+
Potassium Borate	10% aqueous	+	+
Potassium Bromate	cold saturated aqueous	+	+
Potassium Bromide	all aqueous	+	+
Potassium Chloride	cold saturated aqueous	+	+
Potassium Chloride	all aqueous	+	+
Potassium Chromate	cold saturated aqueous	+	+
Potassium Cyanide	cold saturated aqueous	+	+
Potassium Iodide	cold saturated aqueous	+	+
Potassium Nitrate (Saltpetre)	50% aqueous	+	+
Potassium Perchlorate	cold saturated aqueous		c
Potassium Permanganate	cold saturated aqueous	+	c
Potassium Persulphate	all aqueous	+	+
Potassium Phosphates	all aqueous	+	+
Potassium Sulphate	all aqueous	+	+
Propane	technically pure liquid	+	c
	technically pure, gaseous	+	c
Propanol	technically pure	+	+
Propargyl Alcohol	7% aqueous	+	c
Propionic Acid	50% aqueous	+	c
	technically pure	+	c
Propylene Glycol	technically pure	+	+
Propylene Oxide	technically pure	o	c
Pyridine	technically pure	-	c
Ramasit Fabric Water Prrofiging Agents	usual commercial	+	+
Slicon Oil		+	c
silver Salts	Cold saturated aqueous	+	+
soap Solution	All aqueous	+	+
sosium acetate	All aqueous	+	+
sodium Bicarbonate	Cold saturated aqueous	+	+

KEY + Recommended o Conditionally Recommended
- Not Recommended c Consult MPI Tech Service Dept.



Medium Name	CONCENTRATION	rating pvc-u	@20°C epdm
sodium Bisulphate	10% aqueous	+	+
sodium Bisulphate	All aqueous	+	+
sodium Bromate	All aqueous	+	c
sodium Bromide	All aqueous	+	+
sodium Carbonate (Soda)	Cold saturated aqueous	+	+
sodium Chlorate	All aqueous	+	+
sodium Chloride	All aqueous	+	+
sodium Chloride	Up to 10%aqueous	o	+
sodium Chromate	Up to 10%aqueous	+	c
sodium Disulphite	All aqueous	+	c
sodium Dithionite (Hydrosulphite)	Up to 10%aqueous	+	c
sodium Fluoride	Cold saturated aqueous	+	+
sodium Hypochlorite	12.5% aactive chlorine aqueous	+	c
sodium Iodine	All aqueous	+	c
sodium Nitrate	Cold saturated aqueous	+	+
sodium Nitrate	Cold saturated aqueous	+	+
sodium Oxalate	Cold saturated aqueous	+	c
sodium Persulphate	Cold saturated aqueous	+	c
sodium Phosphate	Cold saturated aqueous	+	+
sodium Silicate	Cold saturated aqueous	+	+
sodium Sulphate	Cold saturated aqueous	+	+
sodium Sulphide	Cold saturated aqueous	+	+
sodium Thiosulphate	Cold saturated aqueous	+	+
spindle Oil		o	c
spinning Bath Acids Containing Carbon Disulphide	100mg CS 2/1	+	c
stannous Chloride	Cold saturated aqueous	+	c
starch Solution	All aqueous	+	+
starch Syrup	Usual commercial	+	c
stearic Acid	Technically pure	+	c
succinic Acid	All aqueous	+	c
sugar Syrup	Usual commercial	+	c
sulphur	Technically pure	o	+
sulphur Dioxide	Technically pure anhydrous	+	+
	all moist	+	+
	technically pure liquid	-	+
sulphur Trioxide		-	c
sulphuric Acid	Up to 40%aqueous	+	+
	up to 60%aqueous	+	+
	up to 80%aqueous	+	+
	90%aqueous	+	+
	96%aqueous	+	+
sulphurous Acid	Saturated aqueous	+	c
sulphuric Chloride	Technically pure	-	c
tallow	Technically pure	+	c
Tannic Acid	All Aqueous	+	+
Tanning Extracts From Plant	Usual	+	c

Medium Name	CONCENTRATION	rating pvc-u	@20°C epdm
Tartaric Aid	All Aqueous	+	c
Tetrachloroethane	Technically pure	-	c
Tetreathyl Lead	Technically pure	+	c
Tetrahydrofurane	Technically pure	-	o
Tetrahydronaphtalene	Technically pure	-	c
Thionyl Chloride	Technically pure	-	c
Toluene	Technically pure	-	c
Thionylphosphate	Technically pure	-	+
Trichloroethane	Technically pure	-	c
Trichloroacetic Acid	Technically pure	o	o
	50% aqueous	+	o
Trichloro Ethane	Technically pure	-	c
Tricresyl Phosphate	Technically pure	-	+
Triethanolamine	Technically pure	o	c
Troctyl Phosphate	Technically pure	-	c
Turpentine Oil	Technically pure	+	c
Urea	up to 30% aqueous	+	c
Urine	Technically pure	+	+
Vegetables Oils & Fats	Technically pure	+	+
Vinegar	Technically pure	+	+
Vinyl Acetate	Technically pure	-	+
Viny Chloride	Technically pure	-	+
Viscose Spinning Solution		+	c
Waste Gase	all	+	c
Containing Carbon Dioxide			
Carbon Mono Xide	all	+	+
Hydrochloric Acid	all	+	+
Hydrogen Flouride	Traces	+	+
Nitrous Gases	Traces	+	+
Sulphur Dioxide	Traces	+	+
Sulphur Trioxide	Traces	+	+
Sulphuric Acid	all	+	+
Water	Condensed	+	+
Water	distilled deionised	+	+
Water	drinking	+	+
Water	waste without organic solvent	+	+
Wax Alcohol	Technically pure	+	+
Wetting Agents	up to 5% aqueous	+	+
Wines (Red& White)	Usual Commercial	+	+
Wine Vinegar	Usual Commercial	+	+
Yeast	All Aqueous	+	+
Yeast Wort	Working Concentration	+	+
Xylene	Technically pure	-	c
Zinc Salts	All Aqueous	+	+

KEY + Recommended o Conditionally Recommended
 - Not Recommended c Consult MPI Tech Service Dept.



NOTE

A large rectangular area filled with horizontal grey lines, intended for handwritten notes.

WHY CHOOSE MODERN PLASTIC INDUSTRY LLC ?

- Proven research capability and ability to provide products to suit customer application needs.
- Pipes & fittings at a competitive price.
- Technical service and installation backup.
- One stop facility - wide range of pipes & fittings in UPVC (SWR Drainage), UPVC high pressure, CPVC & PP Compression.
- Prompt deliveries in-house manufacturing facilities for all the pipes and fittings in UAE.
- Quality and reliability - according to international standards, Quality management system (ISO 9001 & kite-mark).
- Operational excellence - precision manufacturing according to the standards using state of the art machinery.
- Duty exemption in GCC countries.
- Service - 24 hours customer service.

Means customer satisfaction and operational excellence.....



صناعة البلاستيك الحديثة (ش.ذ.م.م.)

MODERN PLASTIC INDUSTRY (L.L.C.)
(A Member of Al Shirawi Group of Companies)

ص.ب: 31550، دبي - ا.ع.م، تليفون: +971-4-8851300، فاكس: +971-4-8851301، عنوان الانترنت
P.O. Box: 31550, Dubai - U.A.E., Tel.: +971-4-8851300, Fax: +971-4-8851301
E-mail: marketing@mpi.ae Web Location: <http://www.mpi.ae>

