

Filtration Catalogue

irritec[®] Filtration
don't wait for rain[®] Catalogue

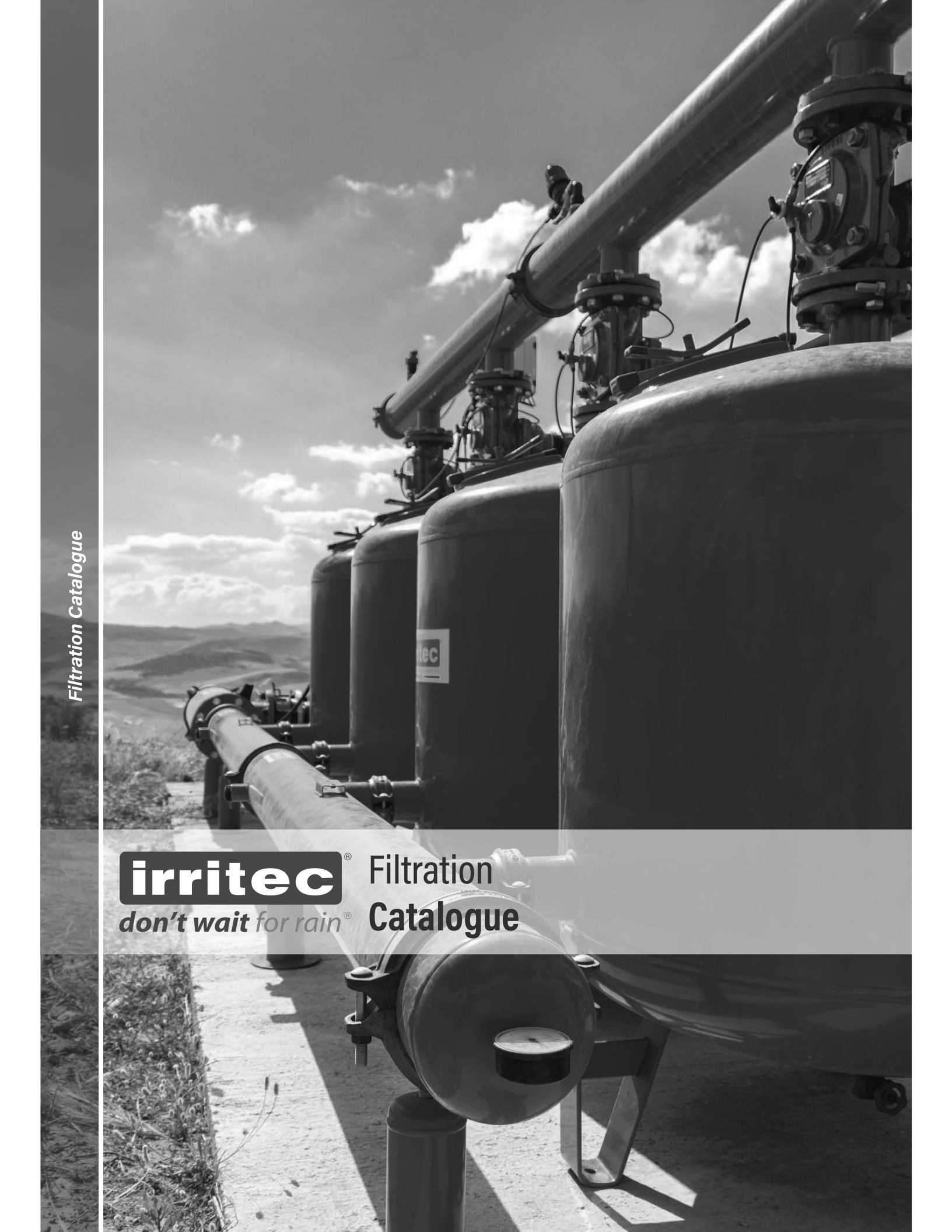

Through its direct presence and widespread international sales network, Irritec[®] follows farmers around the world, assisting them in the choice, design, installation and use of the most appropriate irrigation systems.

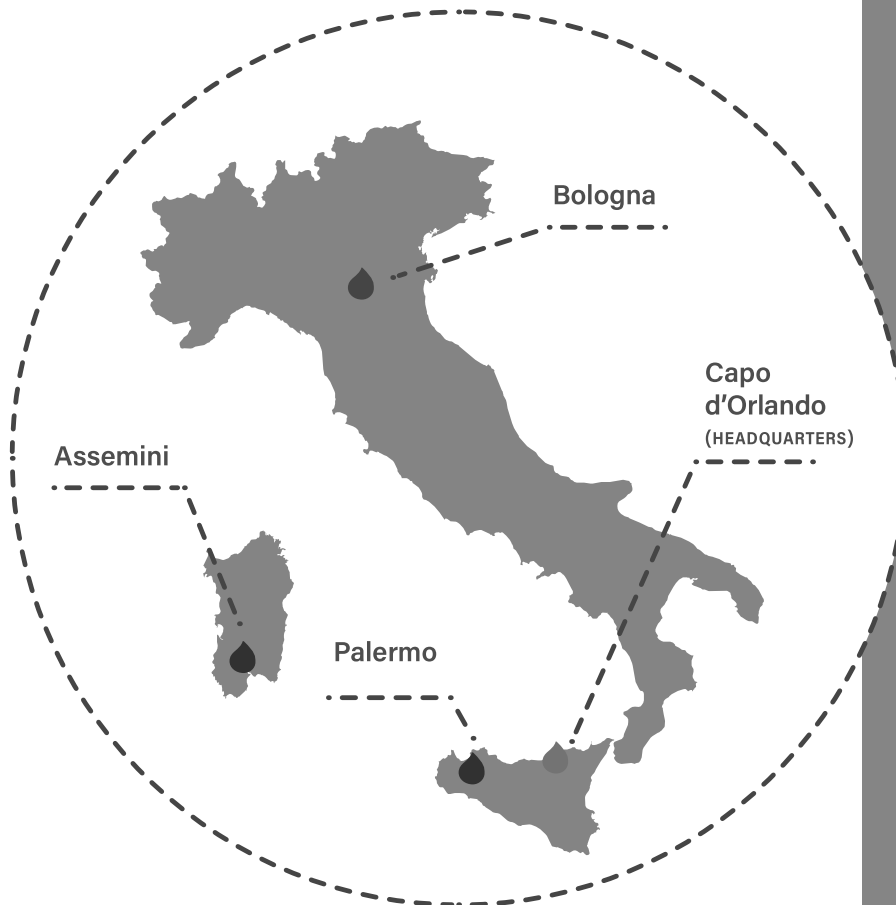

Fresno
USA

Valdosta
USA

Querétaro
MEXICO



PRODUCTION AND SALES SITES



SALES OFFICES



LOGISTICS CENTRES



since

1974

irritec

*A global brand
established in Sicily*

16



*Production and
commercial sites*

+100



Countries in the world

>950



*Professionals
worldwide*

We make life easier for those who take care of the plants, for work and for passion. We work to ensure that every drop is used as well as possible, avoiding the waste of the resources

CONTENTS

6	Manual plastic models	84	Automatic screen filters
8	Rotofilters	85	Filtaworx
10	TGG - TGF	87	FW050 - 100
11	THG - THF	89	FW100EX - 350
12	TIG - TIF		
13	DHF	92	Filter automation kit
14	DIF	93	Filter automation kits
15	EZFilters	94	KTB
18	CEV	95	KPB
19	CHP	96	KFB
20	CGP	97	KFA
21	iFilters	98	KCB
24	YHG - YHF	99	KCA
25	YGG - YGF	100	Certifications
26	YFV		
27	YEV		
28	YDV		
29	YCV		
30	HFP		
32	Automatic plastic models		
34	Rotodisk automatic		
36	TAF		
37	RSL		
40	DAF		
41	RDL		
44	Metal filters		
46	Sand Media Filters		
48	EUV		
51	GCV		
53	ECV		
56	HCV		
58	Accessories for sand media filter batteries		
60	Sand Media Dual Filters		
62	ER		
65	EM		
68	EQ3V		
70	Media Screen Filters		
72	EPV		
73	EPV90°		
74	ESV		
75	EDV		
76	EDV90°		
77	Media Screen Semi Automatic Filters		
79	EAV		
80	EBV		
81	Hydrocyclone		
82	EIV		
83	ETS batteries		

Filtration | Manual plastic models

Irritec's range of plastic filters covers all the requirements of modern irrigation systems. The range of models is characterised by great practicality and robustness. Irrigation system protection is guaranteed by the reliability of all the filtering elements available. Manual plastic filters are used in a wide range of applications:

from the compact in-line filters ideal for residential irrigation (installation into a valve box) to the large filters of the Rotofilters lines ideal for agricultural irrigation of any surface area (secondary and sector filtration).





NON APRIRE LA FASCETTA QUANDO IL FILTRO È IN PRESSIONE
DO NOT OPEN CLAMP WHILE FILTER IS UNDER PRESSURE
NO ABRIR LA ABRAZADERA CON PRESSION EN EL FILTRO
NE PAS OUVRIR LORSQUE LE FILTRE EST SOUS PRESSION

iritec

3
AIR

0-100

0-100

OPEN
10071
18
17
16
15
14
13
12
11
10
9
8
7
6
5
4
3
2
1
0

ROTO Filters™



Flow rate
 Up to 100 m³/h

Filtering Surface
 850 - 3960 cm²

Diameters
 2" - 4"



Filtration Degree (mesh)

Standard filtration degree: 120 mesh

75
 (200 micron)

120
 (130 micron)

155
 (100 micron)

Advantages

- ✓ Easy to **install and maintain**
- ✓ **Irritec Rotodisk**: improves filtration efficiency and delays filter clogging
- ✓ **Extensive range** of models and optionals available

Options

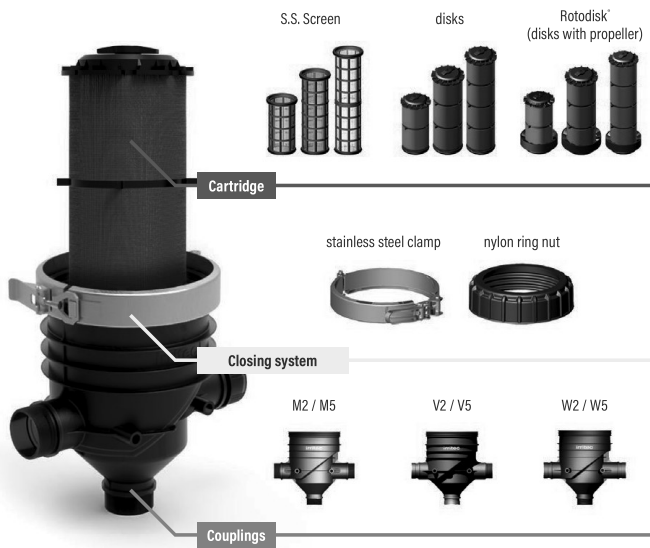

ROTODISK

Rotodisk Technology

Thanks to the baffles at the base, the "Rotodisk" filtering element generates a centrifugal force that keeps some of the solids away from the filtering cartridge, delaying clogging of the filter.

ROTO Filters™

General technical specifications

General Specifications

CONNECTION TYPE	Male threaded (BSP/NPT and/or Grooved)
	Flanged (only DHF and DIF models)
FILTERING CARTRIDGE	Stainless steel screen
	Disks
	Rotodisk
CLOSING SYSTEM	Stainless Steel Clamp or Ring Nut
DISCHARGE	Female Thread 3/4" BSP
PRESSURE GAUGE CONNECTIONS	Female threads 1/4" BSP







Construction materials

BODY	Reinforced polyamide
COVER	Reinforced polyamide
FILTERING ELEMENT	Stainless steel screen: Polypropylene + stainless steel screen Poly screen: Polypropylene + Polyester screen Disks: Polypropylene disks and structure
TIGHTENING RING NUT (mod. TGG, THG TIG)	Reinforced polyamide
CLOSING CLAMP (mod. TGF, THF & TIF)	Stainless Steel AISI 304

Conditions of use

PH RANGE	4$pH$$11$
MAX TEMPERATURE	60 °C / 140 °F
MAX PRESSURE	10 bar at 20°C

Selecting the correct model

DIAMETER		2"		3"		4"	
MODEL	TG*	TH*	TI*	DHF	DIF		
							
General Specifications	FILTRATION DEGREE	75 - 120 - 155 mesh (200 - 130 - 100 micron)					
	CLOSING MECHANISM	Nylon ring nut - Stainless Steel Clamp			Stainless Steel Clamp		
	MAXIMUM FLOW RATE	30 m³/h		50 m³/h		100 m³/h	
	FILTERING SURFACE	960 cm² (850 screen)	1470 cm² (1290 screen)	1980 cm² (1720 screen)	2940 cm² (2580 screen)	3960 cm² (3440 screen)	
	FILTERING CAPACITY	MEDIUM	HIGH	MEDIUM	GOOD	VERY HIGH	GOOD
Applications	 AGRICULTURE	Primary Filtration (Good quality well water) Secondary Filtration (Safety and/or sector filters)					
	 LANDSCAPE	Primary Filtration (Good quality well water)					

TGG - TGF



Description

2" filter with compact filtering element. Small footprint and possibility of in-line or 90° installation. Stainless Steel screen, Disk or Rotodisk filtering elements. Closing system with 2 options: stainless steel clamp (mod. TGF) or reinforced polyamide Ring Nut (mod. TGG). Its compact size makes it ideal for use as a sector filter.

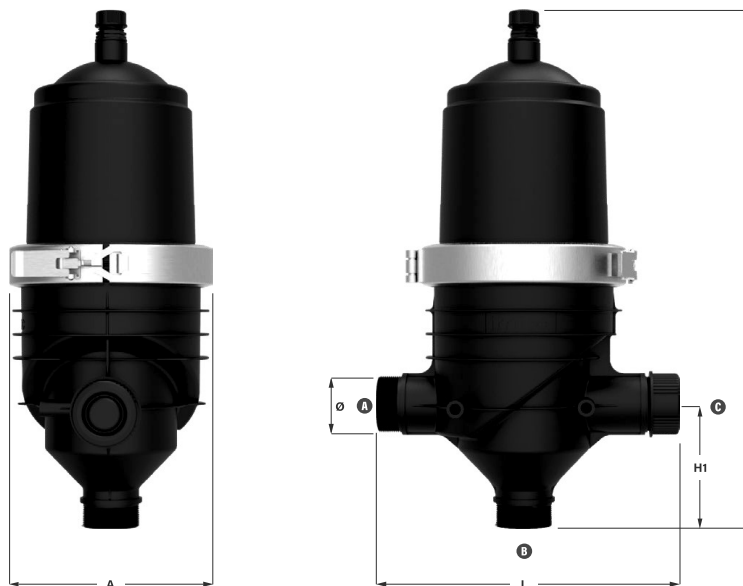

Diameter	Closure	Filtering Element	Code	PN	Maximum flow rate (m³/h)	Filtering Surface (cm²)	L (mm)	A (mm)	H (mm)	H1 (mm)	Weight (kg)
2"	Ring nut	stainless steel screen	IFTGGGixyyFON	10	30	830	310 (M) 327 (V, W)	250	510	130	4.5
		disks	IFTGGGDxyyFON			960					5.6
		Rotodisk	IFTGGGExyyFON			960					5.7
	Stainless Steel Clamp	stainless steel screen	IFTGFGixyyFON			830					4.2
		disks	IFTGFGDxyyFON			960					5.3
		Rotodisk	IFTGFGExyyFON			960					5.4

Filtering Cartridge

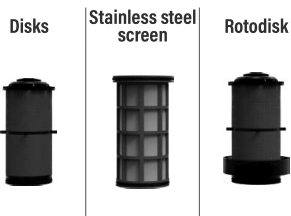

Connections

yy: connections (replace with:)

Ref.	A	B	C
M2	BSP	BSP	BSP
V2	GRV	GRV	BSP
W2	GRV	BSP	GRV
M5	NPT	NPT	NPT
V5	GRV	GRV	NPT
W5	GRV	NPT	GRV

BSP: male thread BSP - NPT: male thread NPT - GRV: grooved

Filtration degree (mesh)

x: mesh (replace with:)

Ref.	Mesh	Micron	Colour
H	75	200	
L	120	130	
N	155	100	

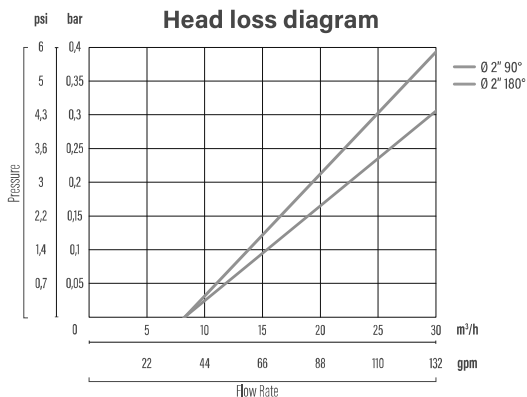

TGG



TGF



THG - THF **ROTO**Filters™

Description

Available in 2" or 3" versions. Both in-line or 90° installation possible. Stainless Steel screen, Disk or Rotodisk filtering elements. Closing system with 2 options: stainless steel clamp (mod. THF) or reinforced polyamide Ring Nut (mod. THG).

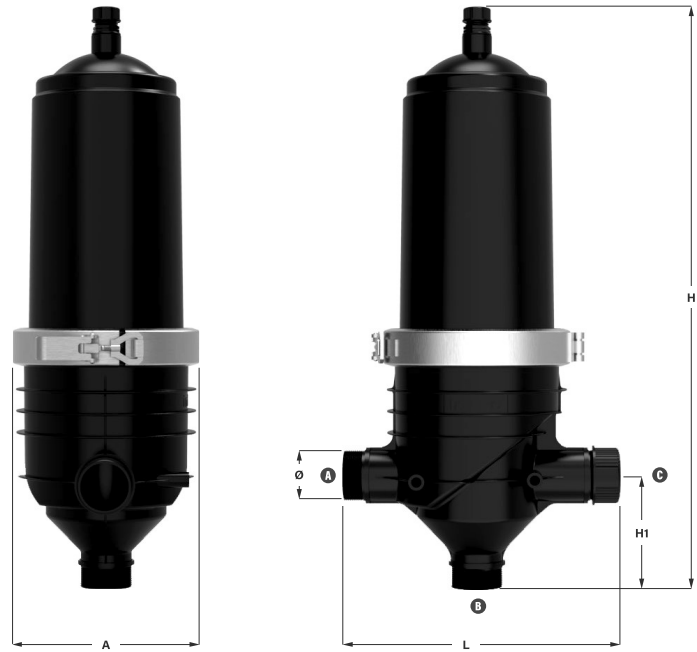

Diameter	Closure	Filtering Element	Code	PN	Maximum flow rate m ³ /h	Filtering Surface cm ²	L (mm)	A (mm)	H (mm)	H1 (mm)	Weight (kg)	
2"	Ring nut	Stainless Steel Screen	IFTHGGixyyFON	10	30	1290	310 (M) 327 (V, W)	250	660	130	5.5	
		Disks	IFTHGGDxyyFON			1470					6.9	
		Rotodisk	IFTHGGExyyFON			1470					7	
	Stainless Steel Clamp	Stainless Steel Screen	IFTHFGixyyFON			1290					5.2	
		Disks	IFTHFGDxyyFON			1470					6.6	
		Rotodisk	IFTHFGExyyFON			1470					6.7	
3"	Ring nut	Stainless Steel Screen	IFTHGIlxyyFON		10	50	1290	310 (M) 327 (V, W)	250	670	140	5.7
		Disks	IFTHGIDxyyFON				1470					7.1
		Rotodisk	IFTHGIExyyFON				1470					7.2
	Stainless Steel Clamp	Stainless Steel Screen	IFTHFIixyyFON				1290					5.4
		Disks	IFTHFIDxyyFON				1470					6.8
		Rotodisk	IFTHFIExyyFON				1470					6.9

Filtering Cartridge

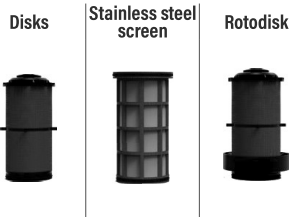

Connections

yy: connections (replace with:)

Ref.	A	B	C
M2	BSP	BSP	BSP
V2	GRV	GRV	BSP
W2	GRV	BSP	GRV
M5	NPT	NPT	NPT
V5	GRV	GRV	NPT
W5	GRV	NPT	GRV

BSP: male thread BSP - NPT: male thread NPT - GRV: grooved

Filtration degree (mesh)

x: mesh (replace with:)

Ref.	Mesh	Micron	Colour
H	75	200	
L	120	130	
N	155	100	

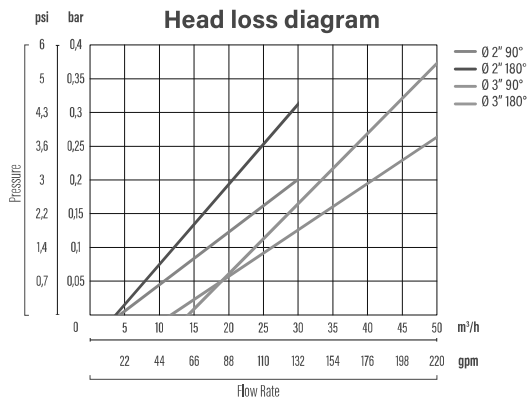

TIG - TIF **RGTG Filters™**

Description

3" filter with large surface area filtering element (1980 cm²). Both in-line or 90° installation possible. Closing system with 2 options: stainless steel clamp (mod. TIF) or reinforced Polyamide Ring Nut (mod. TIG) - Due to its high filtering capacity it is ideal for use as a safety filter (in conjunction with a hydrocyclone or quartzite).

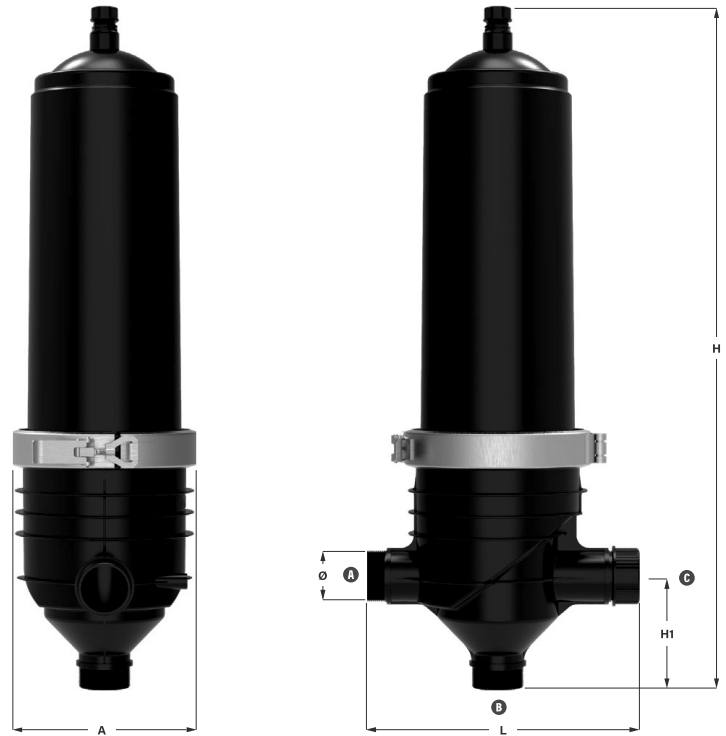

Diameter	Closure	Filtering Element	Code	PN	Maximum flow rate (m ³ /h)	Filtering Surface (cm ²)	L (mm)	A (mm)	H (mm)	H1 (mm)	Weight (kg)			
2"	Ring nut	Stainless steel screen	IFTIGGIxyyFON	10	30	1720	310 (M) 327 (V, W)	250	780	130	6.3			
		Disks	IFTIGDxyyFON			1980					8.1			
		Rotodisk	IFTIGGExyyFON			1980					8.2			
	Stainless Steel Clamp	Stainless steel screen	IFTIFGIxyyFON			1720					6			
		Disks	IFTIFGDxyyFON			1980					7.8			
		Rotodisk	IFTIFGExyyFON			1980					7.9			
3"	Ring nut	Stainless steel screen	IFTIGIxyyFON		10	50			1720	310 (M) 327 (V, W)	250	790	140	6.5
		Disks	IFTIGIDxyyFON						1980					8.3
		Rotodisk	IFTIGIExyyFON						1980					8.4
	Stainless Steel Clamp	Stainless steel screen	IFTIFIIxyyFON						1720					6.2
		Disks	IFTIFIDxyyFON						1980					8
		Rotodisk	IFTIFIExyyFON						1980					8.1

Filtering Cartridge

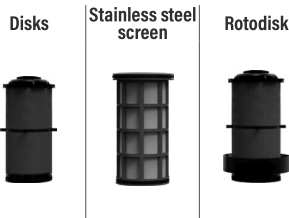

Connections

yy: connections (replace with:)

Ref.	A	B	C
M2	BSP	BSP	BSP
V2	GRV	GRV	BSP
W2	GRV	BSP	GRV
M5	NPT	NPT	NPT
V5	GRV	GRV	NPT
W5	GRV	NPT	GRV

BSP: male thread BSP - NPT: male thread NPT - GRV: grooved

Filtration degree (mesh)

x: mesh (replace with:)

Ref.	Mesh	Micron	Colour
H	75	200	
L	120	130	
N	155	100	

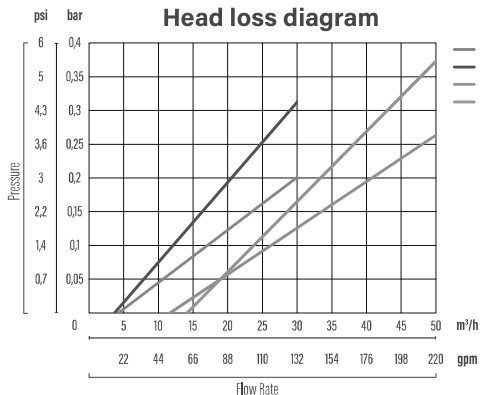

DHF

ROTO Filters™
Twin

Description

Filter with double filtering element, available in 3" and 4" sizes. Also available with flanged connection (DN80 DN100). Its very high filtering capacity makes it ideal for use as a main filter for well water or as a back-up filter (downstream from a quartzite filter) for surface water.

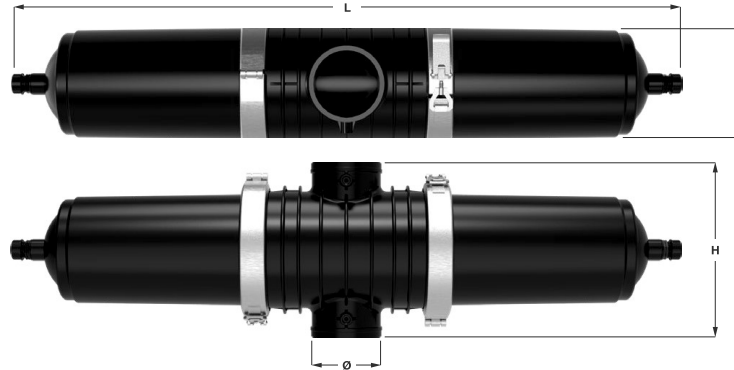

Diameter	Filtering Element	Code	PN	Maximum flow rate (m³/h)	Filtering Surface (cm²)	L (mm)	A (mm)	H (mm)	Weight (kg)
3" / DN80	Stainless steel screen	IFDHFIlxyyF0N	10	50	2580	1020	250	330	12 (M, W) 14 (F)
	Disks	IFDHFIDxyyF0N			2940				15 (M, W) 17 (W)
	Rotodisk	IFDHFIExyyF0N							
4" / DN 100	Stainless steel screen	IFDHFLixyyF0N	10	100	2580	1020	250	345 (M) 390 (W, F)	12 (M, W) 14 (F)
	Disks	IFDHFLDxyyF0N			2940				15 (M, W) 17 (W)
	Rotodisk	IFDHFLExyyF0N							

Filtering Cartridge

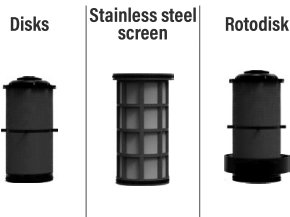

Connections

yy: connections (replace with:)

Ref.	A	B
M2	BSP	BSP
M5	NPT	NPT
W0	GRV	GRV
F0	FLA	FLA

BSP: male thread BSP - NPT: male thread NPT - GRV: grooved

Filtration degree (mesh)

x: mesh (replace with:)

Ref.	Mesh	Micron	Colour
H	75	200	
L	120	130	
N	155	100	

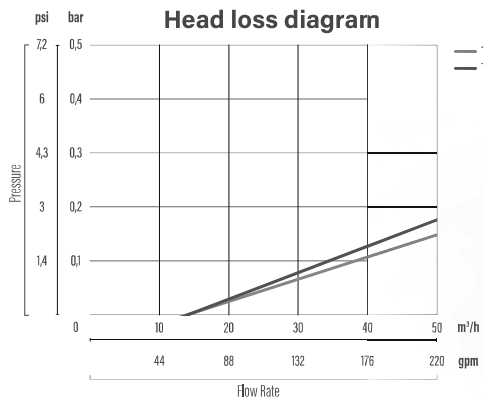

Description

4" filter with large surface area double filtering element (2 x 1980 cm²). Also available with flanged connection DN100. Its very high flow rate and filtering capacity makes it ideal for use as a main filter for well water or as a back-up filter (downstream from a quartzite filter) for surface water.

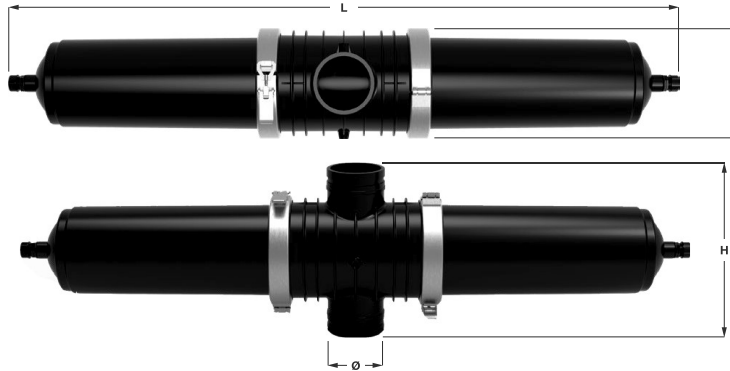

Diameter	Filtering Element	Code	PN	Maximum flow rate (m ³ /h)	Filtering Surface (cm ²)	L (mm)	A (mm)	H (mm)	Weight (kg)
4" / DN 100	Stainless steel screen	IFDIFLxxyFON	10	100	3440	1265	250	345 (M) 390 (W, F)	13 (M, W) 15 (F)
	Disks	IFDIFLDxxyFON			3960				16 (M, W) 18 (F)
	Rotodisk	IFDIFLExxyFON							

Filtering Cartridge

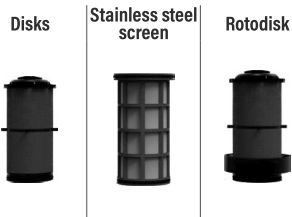

Connections

yy: connections (replace with:)

Ref.	A	B
M2	BSP	BSP
M5	NPT	NPT
W0	GRV	GRV
F0	FLA	FLA

BSP: male thread BSP - NPT: male thread NPT - GRV: grooved

Filtration degree (mesh)

x: mesh (replace with:)

Ref.	Mesh	Micron	Colour
H	75	200	
L	120	130	
N	155	100	

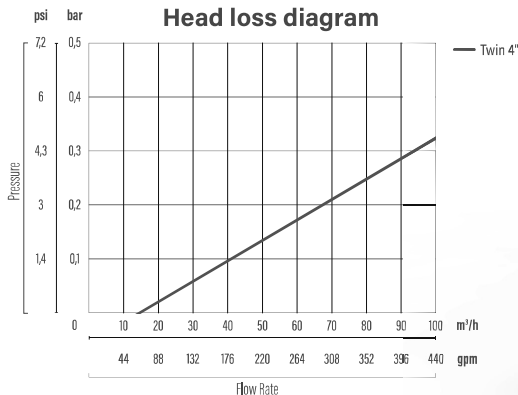

Filtration Catalogue - Plastic manual filters - EZ Filters



EZ Filters



Flow rate
 Up to 50 m³/h

Filtering Surface
 220 - 1470 cm²

Diameters
 1" - 3"



Filtration Degree (mesh)

Standard filtration degree: 120 mesh

75
 (200 micron)

120
 (130 micron)

155
 (100 micron)

Model **CEV**

20
 (800 micron)



200
 (80 micron)

Advantages

- ✓ **Easy** opening and closing system
- ✓ Built with **highly resistant and durable** plastic materials
- ✓ Good value for money

Options

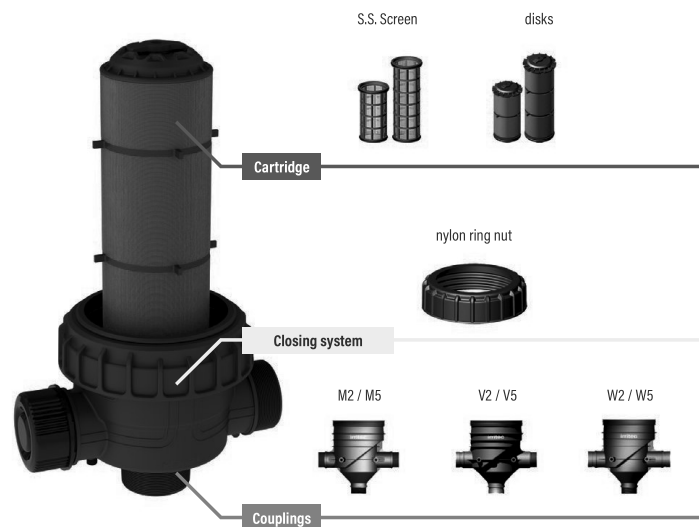

EZ Filters

General technical specifications

General Specifications

CONNECTION TYPE	Male threaded (BSP/NPT and/or Grooved)
FILTERING CARTRIDGE	Stainless steel screen
	Polyester Screen (mod. CEV)
	Disks
CLOSING MECHANISM	Nylon ring nut
DISCHARGE	Male Threaded 3/4" BSP
PRESSURE GAUGE CONNECTIONS	Male Threaded 3/4" BSP







Construction materials

BODY	Polypropylene
COVER	Polypropylene
FILTERING ELEMENT	Stainless steel screen: Polypropylene + stainless steel screen Poly screen: Polypropylene + Polyester screen
	Disks: Polypropylene disks and structure
TIGHTENING RING NUT	Reinforced polyamide
GASKETS	NBR

Conditions of use

PH RANGE	4<pH<11
MAX TEMPERATURE	60 °C / 140 °F
MAX PRESSURE	8 bar a 20°C - 10 bar a 20°C (mod. CEV)

Selecting the correct model

DIAMETER	1"	2"		3"		
MODEL	CEV 	CGP 	CHP 	CGP 	CHP 	
General Specifications	20 - 30 - 50 - 75 - 100 - 120 - 155 - 200 mesh		75 - 120 - 155 mesh			
	800 - 500 - 300 - 200 - 160 - 130 - 100 - 80 micron		200 - 130 - 100 micron			
	Polypropylene cover		Nylon nut			
	7 m³/h		30 m³/h		50 m³/h	
	260 cm² (rete 220)		960 cm² (screen 830)	1470 cm² (screen 1290)	960 cm² (screen 830)	1470 cm² (screen 1290)
FILTERING CAPACITY	MEDIUM		GOOD	VERY HIGH	LOW	MEDIUM
Applications	 AGRICULTURE Accessory filtration (tanks, machinery, etc.)		Secondary filtration (security and/or sector filters)			
	 LANDSCAPE Secondary filtration (Valve Boxes) Primary Filtration (Good quality well water)		Primary Filtration - well water / high quality			

CEV EZ Filters

Description

Inline filter with a "T" design and a high filtering surface. Available in the 1" size. Filter elements in discs, stainless steel mesh, or polyester mesh. Ideal for filtration applications in small and medium irrigation systems and in machinery for fertigation.

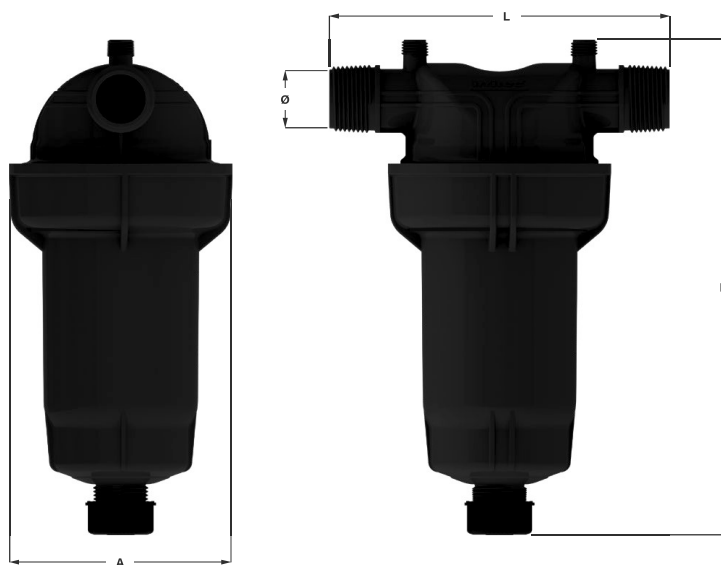

Diameter	Filtering Element	Code	PN	Maximum flow rate (m ³ /h)	Filtering Surface (cm ²)	L (mm)	A (mm)	H (mm)	Weight (kg)
1"	Disks	IFCEVDDxyyCON	10	7	260	170	110	260	0,5
	Stainless steel screen	IFCEVDlxyyCON			220				0,36
	Polyester Screen	IFCEVDPxyyCON							

Filtering Cartridge

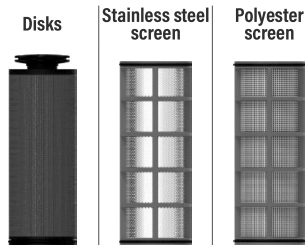

Connections

yy: connections (replace with:)

Ref.	Fittings
M2	Threaded BSP (M/M)
M5	Threaded NPT (M/M)

Filtration degree (mesh)

x: mesh (replace with:)

Ref.	Mesh	Micron	Inox	Poly	Dischi	Colore
E	20	800	✓	✓		
F	30	500	✓	✓		
G	50	300	✓	✓		
H	75	200	✓	✓		
I	100	160	✓	✓		
L	120	130	✓	✓	✓	
N	155	100	✓	✓		
P	200	80	✓	✓		



CHP EZ Filters

Description

Available in 2" or 3" versions. Can be installed in-line or at a 90° angle. Filter elements in stainless steel mesh or discs. Suitable for most irrigation applications.

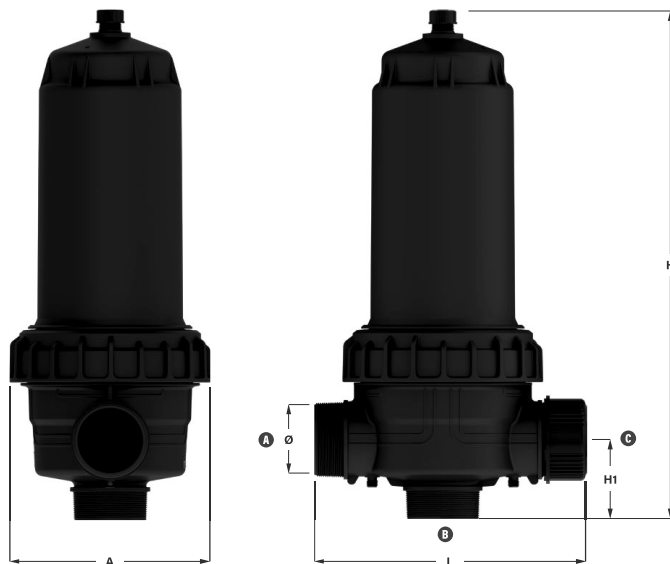

Diameter	Filtering Element	Code	PN	Maximum flow rate (m ³ /h)	Filtering Surface (cm ²)	L (mm)	A (mm)	H (mm)	H1 (mm)	Weight (kg)
2"	Disks	IFCHPGDxyyFON	8	30	1470	290	240	575	76	5,3
	Stainless steel screen	IFCHPGIxxyFON			1290					4,0
3"	Disks	IFCHPIDxyyFON		50	1470	308		595	96	5,7
	Stainless steel screen	IFCHPIIxxyFON			1290					4,4

Filtering Cartridge

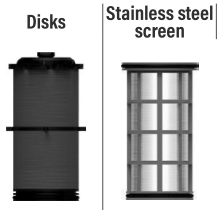

Connections

yy: connections (replace with:)

Ref.	A	B	C
M2	BSP	BSP	BSP
V2	GRV	GRV	BSP
W2	GRV	BSP	GRV
M5	NPT	NPT	NPT
V5	GRV	GRV	NPT
W5	GRV	NPT	GRV

BSP: male thread BSP - NPT: male thread NPT - GRV: grooved

Filtration degree (mesh)

x: mesh (replace with:)

Ref.	Mesh	Micron	Colour
H	75	200	
L	120	130	
N	155	100	



CGP EZ Filters

Description

Filter with a compact filtering element. Reduced size and possibility of installation in-line or at a 90° angle. Filter elements in stainless steel mesh or discs. Thanks to its compactness, it is ideal for use as a sector filter.

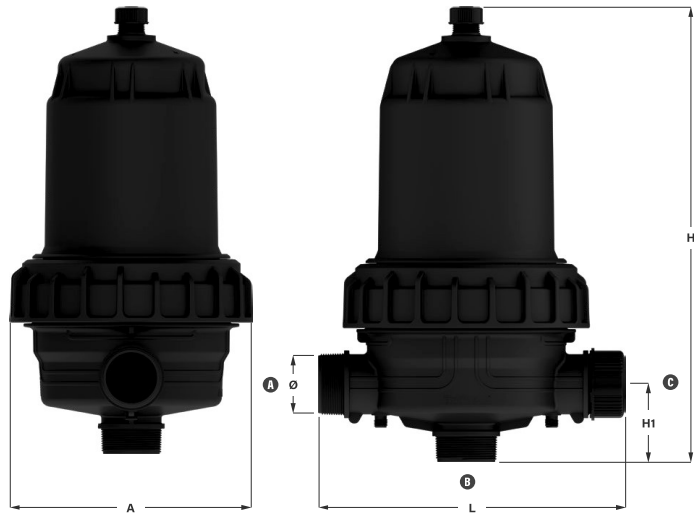

Diameter	Filtering Element	Code	PN	Maximum flow rate (m ³ /h)	Filtering Surface (cm ²)	L (mm)	A (mm)	H (mm)	H1 (mm)	Weight (kg)
2"	Disks	IFCGPGDxyyFON	8	30	960	290	240	436	76	4,0
	Stainless steel screen	IFCGPGIxyyFON			830					3,1
3"	Disks	IFCGPIDxyyFON		50	960	308		456	96	4,4
	Stainless steel screen	IFCGPIIxyyFON			830					3,5

Filtering Cartridge

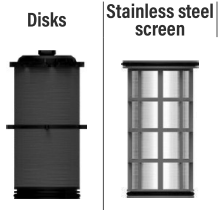

Connections

yy: connections (replace with:)

Ref.	A	B	C
M2	BSP	BSP	BSP
V2	GRV	GRV	BSP
W2	GRV	BSP	GRV
M5	NPT	NPT	NPT
V5	GRV	GRV	NPT
W5	GRV	NPT	GRV

BSP: male thread BSP - NPT: male thread NPT - GRV: grooved

Filtration degree (mesh)

x: mesh (replace with:)

Ref.	Mesh	Micron	Colour
H	75	200	
L	120	130	
N	155	100	





iFilters™



Flow rate
Up to 50 m³/h



Filtering Surface
100 - 1515 cm²



Diameters
3/4" - 3"



Filteration Degree (mesh)

Standard filtration degree: 120 mesh (130 micron)

20
(800 micron)



200
(80 micron)

Advantages

- ✓ Constructed with durable, **high strength plastics**
- ✓ **Small footprint** and highly versatile.
- ✓ Excellent **value for money**

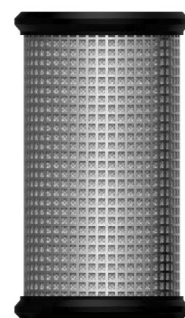
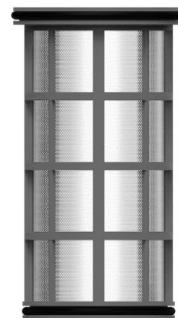

iFilters™

General technical specifications

General Specifications		Construction materials	
CONNECTION TYPE	Male threaded (BSP/NPT) Female threaded (Swivel BSP)	BODY	Polypropylene
FILTERING CARTRIDGE	Stainless steel screen	COVER	Polypropylene
	Disks	FILTERING ELEMENT	Stainless steel screen: Polypropylene + stainless steel screen Poly screen: Polypropylene + Polyester screen Disks: Polypropylene disks and structure
	Polyester Screen		
DISCHARGE	Male Threaded 3/4" BSP (mod. YCV-YDV-YEV-YFV) Female Threaded 3/4" BSP (mod. YGG-YGF-YHG-YHF)	TIGHTENING RING NUT (mod. YGG - YHG)	Reinforced polyamide
PRESSURE GAUGE CONNECTIONS	Male Threaded 1/4" BSP (mod. YDV-YEV-YFV)	CLOSING CLAMP (mod. YGF - YHF)	Stainless Steel AISI 304
	Female Threaded 1/4" BSP (mod. YGG-YGF-YHG-YHF)	GASKETS	NBR

Conditions of use

PH RANGE	4$pH$$11$
MAX TEMPERATURE	60 °C / 140 °F
MAX PRESSURE	8 bar (YFV - YG* - YH*)
	10 bar (YCV - YDV - YEV)

Selecting the correct model

DIAMETER	3/4" - 1"		1" 1/4	1 1/2"	2"	3"
MODEL						
General Specifications	FILTRATION DEGREE: 20 - 30 - 50 - 75 - 100 - 120 - 155 - 200 mesh				75 - 120 - 155 mesh	
	FILTRATION DEGREE: 800 - 500 - 300 - 200 - 160 - 130 - 100 - 80 micron				200 - 130 - 100 micron	
	CLOSING MECHANISM: Polypropylene cover				Nylon ring nut - Stainless Steel Clamp	
	MAXIMUM FLOW RATE: 5 m³/h		10 m³/h		20 m³/h	
	MAXIMUM FLOW RATE: 25 m³/h					
FILTERING SURFACE	100 cm²	170 cm² (screen: 160)	260 cm² (screen: 220)	500 cm² (screen: 450)	960 cm² (830-990 screen)	1470 cm² (1290-1515 screen)
FILTERING CAPACITY	LOW	MEDIUM	MEDIUM	MEDIUM	GOOD	VERY HIGH MEDIUM
Applications	 Accessory filtration (tanks, machinery, etc.)			Secondary filtration (security and/or sector filters)		
	 Secondary filtration (Valve Boxes) Primary Filtration (Good quality well water)			Primary Filtration - well water / high quality		

YHG - YHF



Description

Large in-line filter, available in 2" or 3" sizes. Disk, stainless steel screen or polyester screen filtering elements. Closing system with 2 options: stainless steel clamp (mod. YHF) or reinforced Polyamide Ring Nut (mod. YHG). Ideal as a sector filter or as a primary filter in good quality well water applications

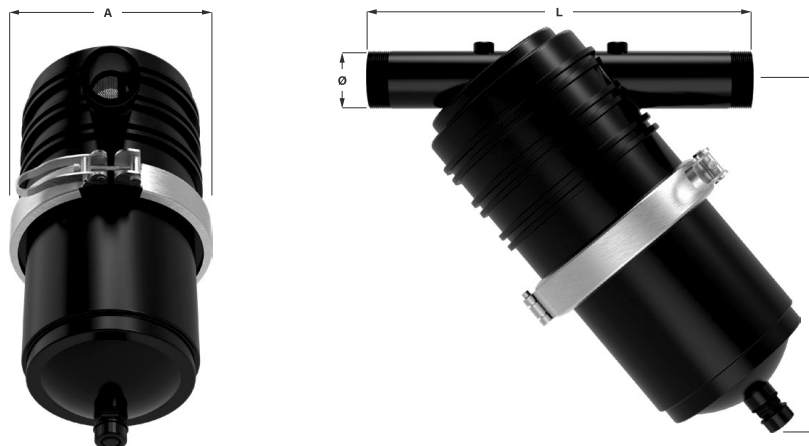

Diameter	Closure	Filtering Element	Code	PN	Maximum flow rate (m ³ /h)	Filtering Surface (cm ²)	L (mm)	A (mm)	H (mm)	Weight (kg)	
2"	Ring nut	Stainless Steel Screen	IFYHGGixyyCON	8	25	1290	400	250	370	3.9	
		Polyester Screen	IFYHGGPxyyCON			1515				4	
		Disks	IFYHGGDxyyCON			1470				5.4	
	Stainless Steel Clamp	Stainless Steel Screen	IFYHFGixyyCON			1290				3.6	
		Polyester Screen	IFYHFGPxyyCON			1515				3.7	
		Disks	IFYHFGDxyyCON			1470				5.1	
3"	Ring nut	Stainless Steel Screen	IFYHGIixyyCON		50	50	1290	446	250	370	4.1
		Polyester Screen	IFYHGIpxyyCON				1515				4.2
		Disks	IFYHGIDxyyCON				1470				5.6
	Stainless Steel Clamp	Stainless Steel Screen	IFYHFlixyyCON				1290				3.8
		Polyester Screen	IFYHFIPxyyCON				1515				3.9
		Disks	IFYHFIDxyyCON				1470				5.3

Filtering Cartridge

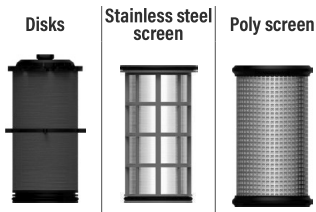

Connections

yy: connections (replace with:)

Ref.	Fittings
M2	Threaded BSP (M/M)
M5	Threaded NPT (M/M)

Filtration degree (mesh)

x: mesh (replace with:)

Ref.	Mesh	Micron	Colour
H	75	200	
L	120	130	
N	155	100	

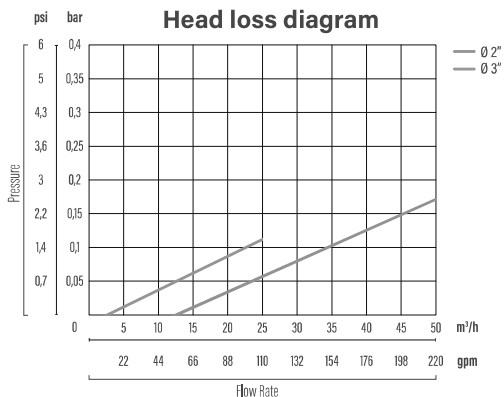

THG

YHF



YGG - YGF



Description

Compact in-line filter available in 2" size. Disk, stainless steel screen or polyester screen filtering elements. Closing system with 2 options: stainless steel clamp (mod. YGF) or reinforced Polyamide Ring Nut (mod. YGG). Its small footprint makes it ideal for use as a sector filter.

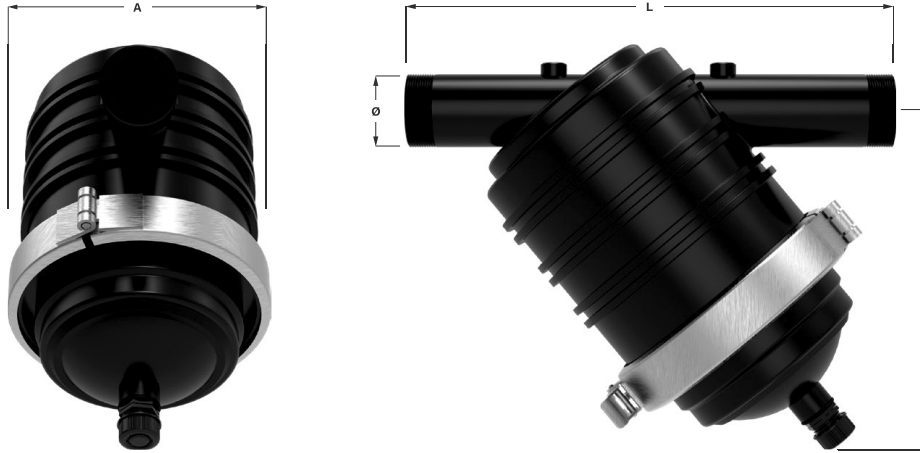

Diameter	Closure	Filtering Element	Code	PN	Maximum flow rate (m³/h)	Filtering Surface (cm²)	L (mm)	A (mm)	H (mm)	Weight (kg)
2"	Ring nut	Stainless steel screen	IFYGGGlxxyCON	8	25	830	400	250	260	3.6
		Polyester Screen	IFYGGGPxyyCON			990				3.5
		Disks	IFYGGGDxyyCON			960				4.4
	Stainless Steel Clamp	Stainless steel screen	IFYGFGlxxyCON			830				3.3
		Polyester Screen	IFYGFGPxyyCON			990				3.2
		Disks	IFYGFGDxyyCON			960				4.1

Filtering Cartridge

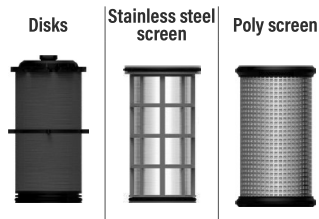

Connections

yy: connections (replace with:)

Ref.	Fittings
M2	Threaded BSP (M/M)
M5	Threaded NPT (M/M)

Filtration degree (mesh)

x: mesh (replace with:)

Ref.	Mesh	Micron	Colour
H	75	200	
L	120	130	
N	155	100	

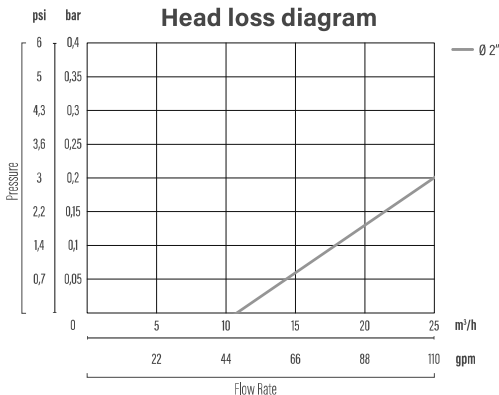

YGG



YGF



Description

Mini version in-line filter, available in 1-1/2" and 2" sizes. Disk, stainless steel screen or polyester screen filtering elements. Small size filter, ideal for secondary filtration applications on small and medium agricultural and residential irrigation systems.

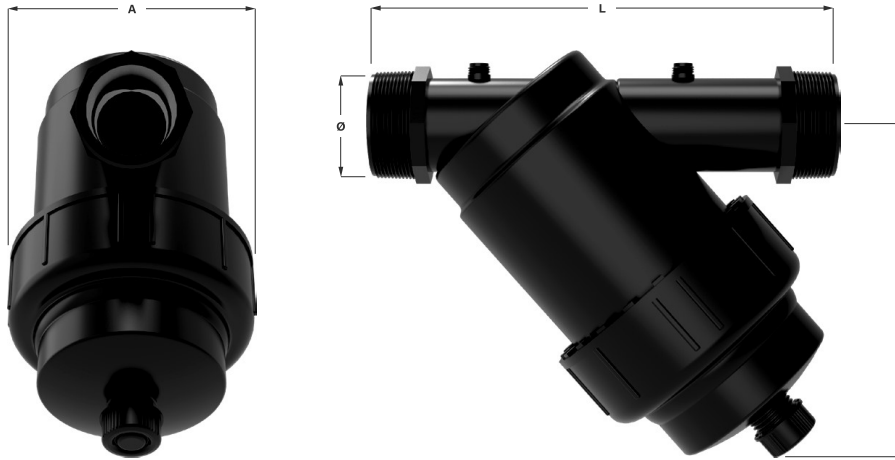

Diameter	Filtering Element	Code	PN	Maximum flow rate (m³/h)	Filtering Surface (cm²)	L (mm)	A (mm)	H (mm)	Weight (kg)
1 1/2"	Stainless steel screen	IFYFVFxxyyCON	8	20	450	258	140	188	0.7
	Polyester Screen	IFYFVPxxyyCON							
	Disks	IFYFVFDxxyyCON							
2"	Stainless steel screen	IFYFVGxxyyCON			450				0.8
	Polyester Screen	IFYFVGPxxyyCON							
	Disks	IFYFVGDxxyyCON							

Filtering Cartridge

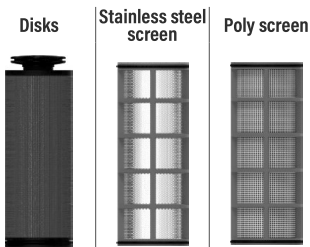

Connections

yy: connections (replace with:)

Ref.	Fittings
M2	Threaded BSP (M/M)
M5	Threaded NPT (M/M)

Filtration degree (mesh)

x: mesh (replace with:)

Ref.	Mesh	Micron	Stainless Steel	Poly	Disks	Colour
E	20	800	✓	✓		
F	30	500	✓	✓		
G	50	300	✓	✓		
H	75	200	✓	✓		
I	100	160	✓	✓		
L	120	130	✓	✓	✓	
N	155	100	✓	✓		
P	200	80	✓	✓		

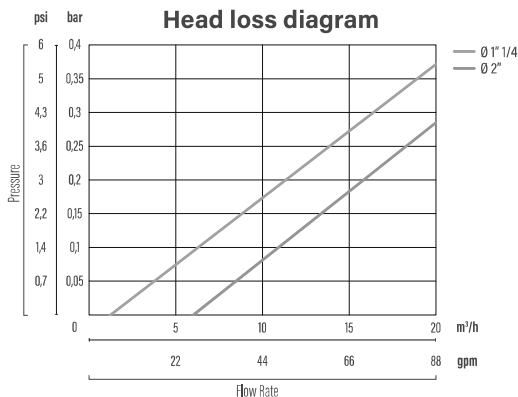

YEV

iFilters

Description

Mini version in-line filter, available in 1-1/4" and 1-1/2" sizes. Disk, stainless steel screen or polyester screen filtering elements. Small footprint filter, ideal for filtration applications on small and medium-sized irrigation systems (valve boxes, pumping unit).

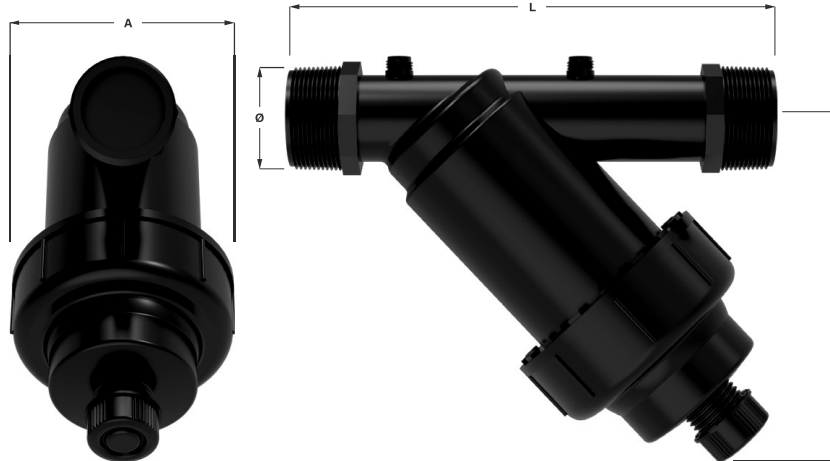

Diameter	Filtering Element	Code	PN	Maximum flow rate (m³/h)	Filtering Surface (cm²)	L (mm)	A (mm)	H (mm)	Weight (kg)
1 1/4"	Stainless steel screen	IFYEVElxxyCON	10	10	220	220	103	152	0.36
	Polyester Screen	IFYEVEPxxyCON			260				
	Disks	IFYEVEDxxyCON			260				
1 1/2"	Stainless steel screen	IFYEVFlxwwCON			220 (M) 225 (W)	220			0.37
	Polyester Screen	IFYEVFPxwwCON				260			
	Disks	IFYEVFDxwwCON				260			

Filtering Cartridge

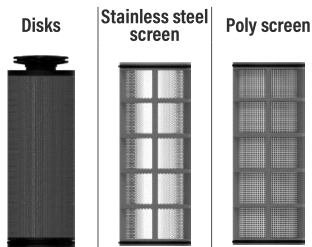

Connections

yy: connections (replace with:)

Ref.	Fittings
M2	Threaded BSP (M/M)
M5	Threaded NPT (M/M)

Connections

ww: connections (replace with:)

Ref.	Fittings
M2	Threaded BSP (M/M)
M5	Threaded NPT (M/M)
W2	Threaded BSP Swivel (F/F)

Filtration degree (mesh)

x: mesh (replace with:)

Ref.	Mesh	Micron	Stainless Steel	Poly	Disks	Colour
E	20	800	✓	✓		
F	30	500	✓	✓		
G	50	300	✓	✓		
H	75	200	✓	✓		
I	100	160	✓	✓		
L	120	130	✓	✓	✓	
N	155	100	✓	✓		
P	200	80	✓	✓		

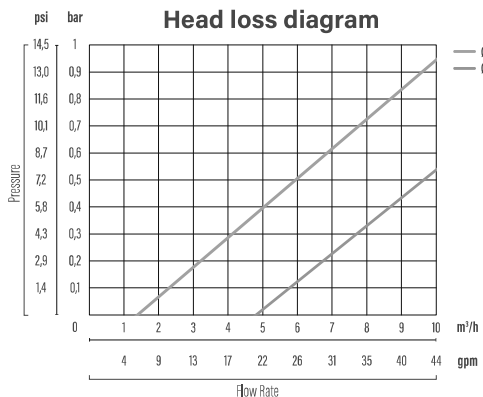

Description

Mini version in-line filter, available in 3/4" and 1" sizes. Disk, stainless steel screen or polyester screen filtering elements. Small footprint filter, ideal for filtration applications on small irrigation systems (valve boxes, pumping unit) and for "accessory" filtration (application on tanks, cisterns and machinery).

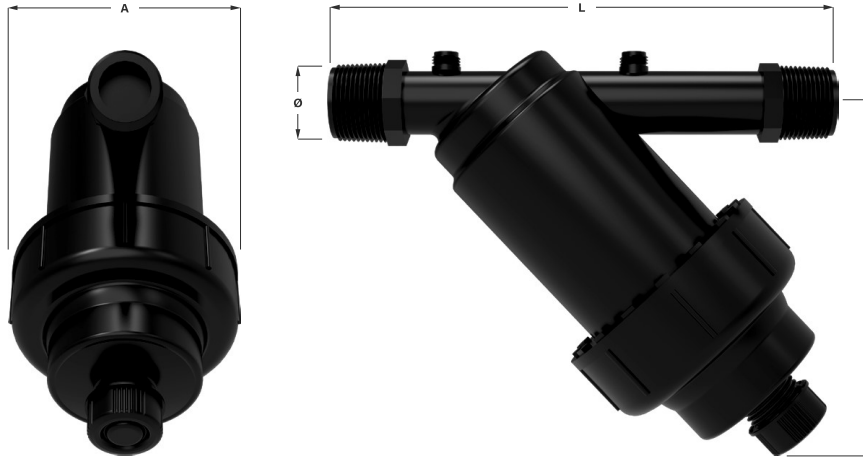

Diameter	Filtering Element	Code	PN	Maximum flow rate (m ³ /h)	Filtering Surface (cm ²)	L (mm)	A (mm)	H (mm)	Weight (kg)
3/4"	Stainless steel screen	IFYDVCxyyCON	10	5	160	152	84	138	0.22
	Polyester Screen	IFYDVCpxyyCON							
	Disks	IFYDVCDxyyCON			170				
1"	Stainless steel screen	IFYDVDlxwwCON			152 (M) 155 (W)	160			0.23
	Polyester Screen	IFYDVDPxwwCON				170			0.31
	Disks	IFYDVDDxwwCON				170			0.31

Filtering Cartridge

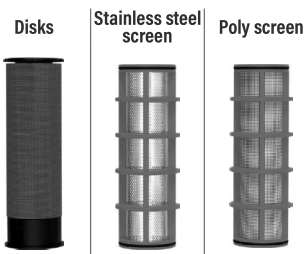

Connections

yy: connections (replace with:)

Ref.	Fittings
M2	Threaded BSP (M/M)
M5	Threaded NPT (M/M)

Connections

ww: connections (replace with:)

Ref.	Fittings
M2	Threaded BSP (M/M)
M5	Threaded NPT (M/M)
W2	Threaded BSP Swivel (F/F)

Filtration degree (mesh)

x: mesh (replace with:)

Ref.	Mesh	Micron	Stainless Steel	Poly	Disks	Colour
E	20	800	✓	✓		
F	30	500	✓	✓		
G	50	300	✓	✓		
H	75	200	✓	✓		
I	100	160	✓	✓		
L	120	130	✓	✓	✓	
N	155	100	✓	✓		
P	200	80	✓	✓		

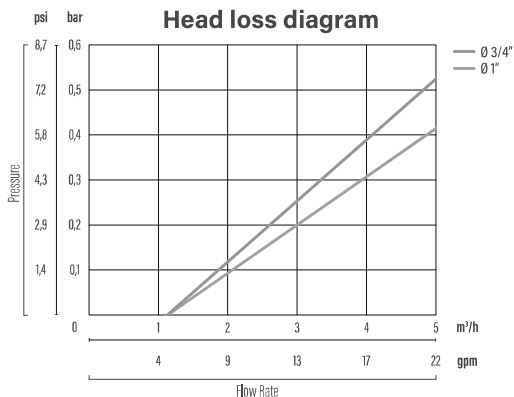

YCV

iFilters

Description

Ultra-compact version in-line filter, available in 3/4" and 1" sizes. Filtering elements: stainless steel screen or polyester screen. Extremely small footprint filter, ideal for secondary filtration applications on small residential irrigation systems (Valve boxes) and for "accessory" filtration (application on tanks, cisterns and machinery).



Diameter	Filtering Element	Code	PN	Maximum flow rate (m³/h)	Filtering Surface (cm²)	L (mm)	A (mm)	H (mm)	Weight (kg)
3/4"	Stainless steel screen	IFYCVClxxySON	10	5	100	123	72	135	0.16
	Polyester Screen	IFYCVCpxxySON							
1"	Stainless steel screen	IFYCVCpxxySON							
	Polyester Screen	IFYCVCpxxySON							0.17

Filtering Cartridge

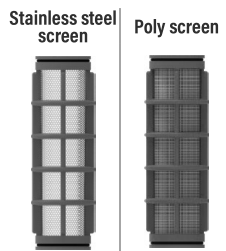

Connections

yy: connections (replace with:)

Ref.	Fittings
M2	Threaded BSP (M/M)
M5	Threaded NPT (M/M)

Filtration degree (mesh)

x: mesh (replace with:)

Ref.	Mesh	Micron	Stainless Steel	Poly	Disks	Colour
E	20	800	✓	✓		
F	30	500	✓	✓		
G	50	300	✓	✓		
H	75	200	✓	✓		
I	100	160	✓	✓		
L	120	130	✓	✓	✓	
N	155	100	✓	✓		
P	200	80	✓	✓		

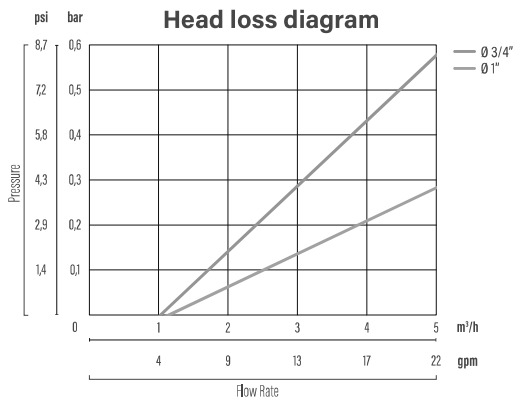

HFP

Description

Centrifugal sand separator (Hydrocyclone) made of plastic material (reinforced polyamide). Available in 2" and 3" sizes. The models are equipped with a large volume collection tank and a manual discharge valve.

Principle of operation

The water enters the cone laterally in a tangential manner. The centrifugal force generated allows the separation of the sand (carried in the outer part of the flow), which is collected in the lower tank. The central part of the flow (solid-free) flows out of the upper outlet.

Advantages

- ✓ Centrifugal separator for well or river water containing sand (and other solids of high specific weight) in suspension
- ✓ Plastic construction
- ✓ High-capacity sand collection tank (supplied equipped with purge valve)
- ✓ TPU protection installed at the base of the cone reduces wear caused by the action of sand.



Flow rate
15 - 52 m³/h



Max Pressure
6 Bar



Diameters
2" - 3"



Couplings	Code	Ø Body (mm)	Flow rate (m ³ /h)	Capacity container (litres)	H (mm)	H1 (mm)	A (mm)	B (mm)	L (mm)	Weight (kg)
2"	IFHFP00M2V0N	206	15÷25	8	940	808	206	151	395	7.6
3"	IFHFP100M2V0N	248	35÷52	10	990	868	248	175	482	9.6

General Specifications

CONNECTION TYPE	Threaded male (BSP)
COLLECTION TANK	Supplied
DISCHARGE	Manual valve
MAX PRESSURE	6 bar

Materials

BODY	Reinforced polyamide
TANK	Reinforced polyamide
CLOSING ELEMENT	Stainless steel clamp and bolt
GASKETS	NBR

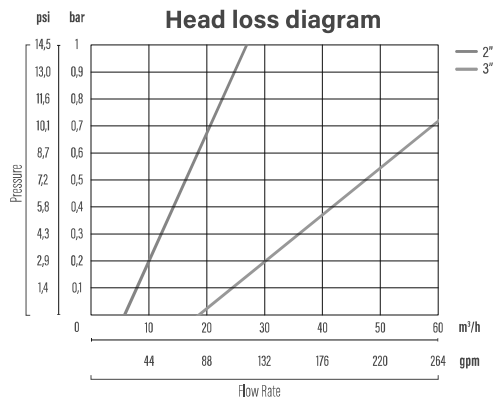

Filtration | Automatic models

The ROTODISK AUTOMATIC range represents a valid solution for the primary filtration of all types of water in an agricultural setting and large green spaces. The range of models makes it possible to manage water flow rates from 20 to 600 m³/h. Fully automatic operation ensures constant efficiency of the irrigation system and

eliminates the need for filter maintenance. Disk filtering elements, with their "three-dimensional" filtration, represent the highest guarantee of reliability for your installations.





ROTODISK®

A U T O M A T I C

Advantages

- ✓ **Irritec Rotodisk®**, device that improves filtration efficiency and slows filter clogging.
- ✓ **Self-cleaning filtering element** guarantees highly efficient backwashing and low water consumption.
- ✓ **Maintenance made easy** without the use of special tools



Filtration

The ROTODISK filtering element generates a centrifugal force that keeps solid particles away from the disks, slowing the rate of clogging. Water passes over the surface of grooved disks and solids are trapped in the filtering element.

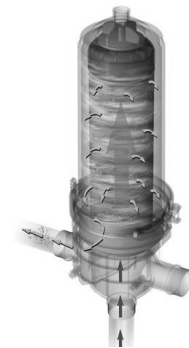

Backwash

Reversing the flow across the filter mass causes the cartridge to decompress and allows the individual disks to separate. The water, through small tangential jets, strikes the surface of the disks, causing them to rotate and ensuring a complete and effective cleaning.



ROTODISK[®]

A U T O M A T I C

PRODUCT RANGE: Automatic single and dual head models



TAF

Automatic disk filter

Diameter: 2" -3"

Maximum flow rate: 24 m³/h (2") | 32 m³/h (3")

Filtering Surface: 1,450 cm²

Filtration degree

75 - 120 - 155 mesh | 200 - 130 - 100 micron



RSL

In-line automatic disk filter batteries

Automatic disk filter batteries with IN-LINE arrangement. Compact and lightweight, they are ideal for application in small to medium/large systems (up to 190 mc/h) on all types of water.



DAF

Double-head automatic disk filter

Diameter: 4"

Maximum flow rate: 64 m³/h

Filtering Surface: 2,900 cm²

Filtration degree

75 - 120 - 155 mesh | 200 - 130 - 100 micron

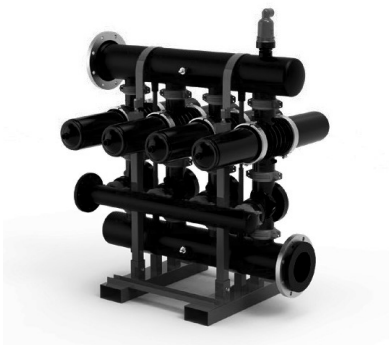

RDL

Double head automatic disk filter battery

DOUBLE HEAD automatic disk filtration batteries Capable of handling high volumes of water while maintaining great portability and a small footprint. Ideal for large installations (190 - 640 mc/h) on all types of water.

TAF

ROTDISK[®]
AUTOMATIC

Description

Rotodisk Automatic filter with single filtering element: to implement the backwash system a battery must be assembled, complete with appropriate backwash valves, manifolds (inlet, outlet and discharge) and a filter automation kit.

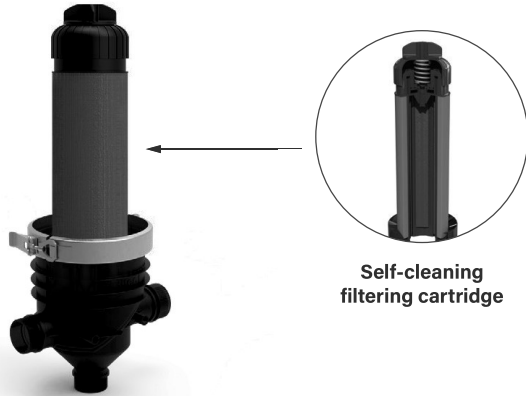

Self-cleaning filtering cartridge

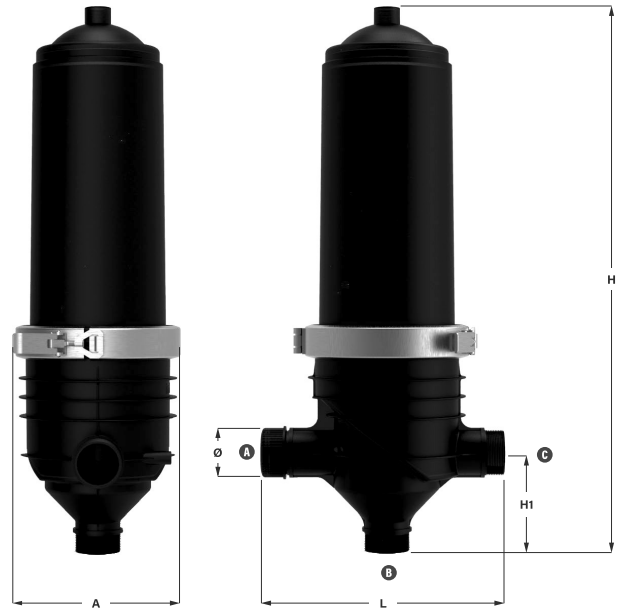

Internal	Code	PN	Max flow rate (m ³ /h)	Filtering Surface (cm ²)	Min pressure backwash (bar)	Min flow rate backwash (m ³ /h)	L (mm)	A (mm)	H (mm)	H1 (mm)	Weight (kg)
2"	IFTAFGExyyFON	10	24	1450	2.8	9	310 (M) 327 (V, W)	250	720	140	8
3"	IFTAFIExyyFON		32								

General Specifications

CONNECTION TYPE	Male threaded (BSP/NPT and/or Grooved)
FILTERING CARTRIDGE	Automatic
CLOSING SYSTEM	Stainless Steel Clamp
DISCHARGE	Female Thread 3/4" BSP (not perforated)
PRESSURE GAUGE CONNECTIONS	Female threads 1/4" BSP

Conditions of use

PH RANGE	4 < pH < 11
MAX TEMPERATURE	60 °C / 140 °F
MAX PRESSURE	10 bar at 20°C

Connections

yy: connections (replace with:)

Ref.	A	B	C
M2	BSP	BSP	BSP
V2	GRV	GRV	BSP
W2	GRV	BSP	GRV
M5	NPT	NPT	NPT
V5	GRV	GRV	NPT
W5	GRV	NPT	GRV

BSP: male thread BSP - NPT: male thread
NPT - GRV: grooved

Filtration degree (mesh)

x: mesh (replace with:)

Ref.	Mesh	Micron	Colour	No. of Disks per filtering cartridge
H	75	200		280
L	120	130		321
N	155	100		350

Recommended flow rate (m³/h) according to water quality

Model	Flow rate Maximum	Medium Quality	Poor Quality	Very poor Quality
2"	24	20	17	15
3"	32	25	19	15

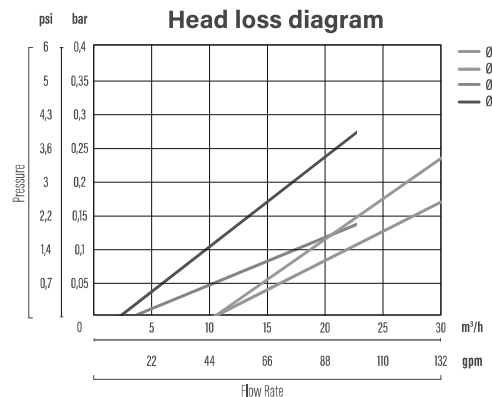
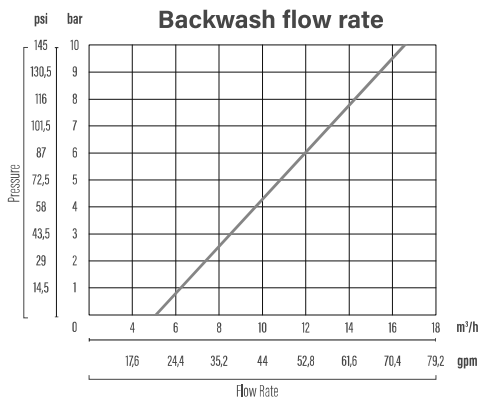

RSL

ROTODISK
AUTOMATIC

Description

Automatic disk filter batteries with IN-LINE arrangement. Compact and lightweight, they are ideal for primary and secondary filtration in small to medium/large systems (up to 190 m³/h) on all types of water.



Flow rate
24 - 192 m³/h



Filtering Surface
1450 - 8700 cm²



Diameters
2" - 8"



Filtration Degree (mesh)

Standard filtration degree: 120 mesh

75
(200 micron)

120
(130 micron)

155
(100 micron)

Advantages

- ✓ **Easy to install** and maintain (no tools required for maintenance)
- ✓ Constructed with durable, **high strength plastics**
- ✓ **Small footprint** and highly versatile.







Construction materials

BACKWASH VALVES	Reinforced polyamide
GROOVED COUPLINGS	Cast iron
SUPPORTS	Painted Steel Stainless Steel
MANIFOLDS	High-density polyethylene

Conditions of use

PH RANGE	4 < pH < 11
MAX TEMPERATURE	60 °C / 140 °F
MAX PRESSURE	10 bar at 20°C

Selecting the correct model

MANIFOLDS DIAMETER		2"	3"DN80	4"		6"		4"	6"		8"			
No. OF ELEMENTS PER DIAMETER		1 x 2"	2 x 2"	2 x 2"	3 x 2"	4 x 2"	5 x 2"	6 x 2"	2 x 3"	3 x 3"	4 x 3"	5 x 3"	5 x 3"	6 x 3"
MODEL														
General Specifications	CONNECTION TYPE	Threaded F			Flanged									
	FILTRATION DEGREES	75 - 120 - 155 mesh (200 - 130 - 100 micron)												
	BACKWASH VALVE	2"						3"						
	MAXIMUM FLOW RATE	24 m ³ /h	48 m ³ /h	72 m ³ /h	96 m ³ /h	120 m ³ /h	144 m ³ /h	64 m ³ /h	96 m ³ /h	128 m ³ /h	160 m ³ /h	192 m ³ /h		
	FILTERING SURFACE	1450 cm ²	2900 cm ²	4350 cm ²	5800 cm ²	7250 cm ²	8700 cm ²	2900 cm ²	4350 cm ²	5800 cm ²	7250 cm ²	8700 cm ²		
	FILTERING CAPACITY	VERY HIGH						HIGH						
Backwash Data	MINIMUM FLOW RATE	9 m ³ /h												
	DISCHARGE MANIFOLDS DIAMETER	3" GRV / DN80												
	MINIMUM PRESSURE	2.8 bar												
	MIN TIME BACKWASH	20 - 30 seconds												
	WASH CRITERIA	ΔP max 0.5 bar - washing cycles according to water quality												
Applications	 AGRICULTURE	Primary filtration on medium to large sized systems (water quality from POOR to GOOD) Secondary filtration on "problematic" water (water with high lime and clay content)												
	 LANDSCAPE	Main filtration on large sized systems (parks, public green spaces, golf courses etc.)												

Head loss diagram
(single filtering element)

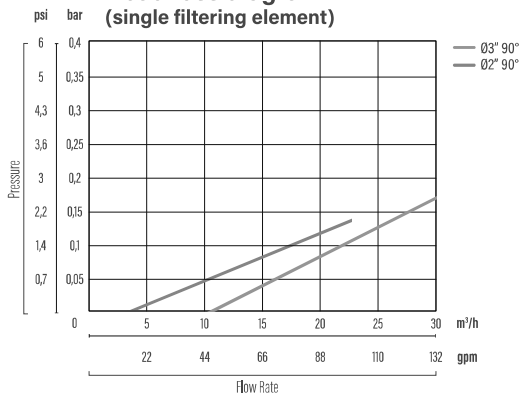

Recommended flow rate (m³/h)
according to water quality

Model	Configuration	Flow rate Maximum	Medium Quality	Poor Quality	Very poor Quality
RSL 2"	1 x 2"	24	20	17	14
	2 x 2"	48	40	34	28
	3 x 2"	72	60	51	42
	4 x 2"	96	80	68	56
	5 x 2"	120	100	85	70
	6 x 2"	144	120	102	84
RSL 3"	2 x 3"	64	50	38	30
	3 x 3"	96	75	57	45
	4 x 3"	128	100	76	60
	5 x 3"	160	125	95	75
	6 x 3"	192	150	114	90

RSL

ROTODISK
AUTOMATIC

Single head

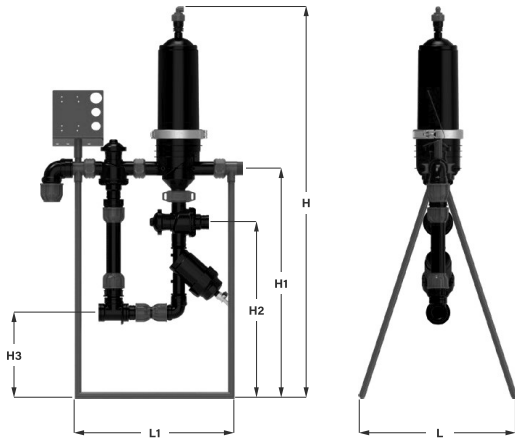

Multi-head

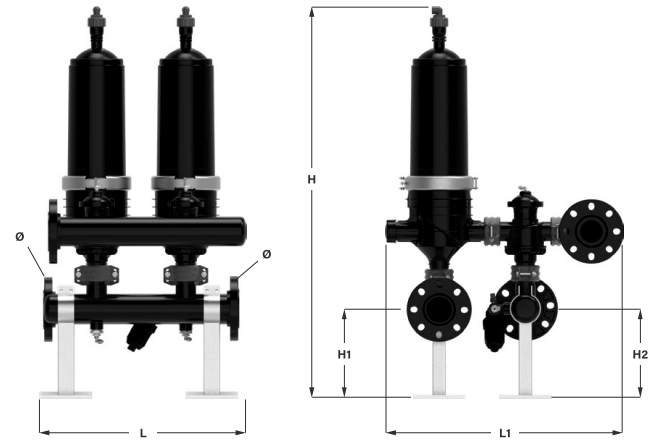

Model	No. of Elements per diameter	Code	Type	Connections	L (mm)	L1 (mm)	H (mm)	H1 (mm)	H2 (mm)	H3 (mm)
2"	1 x 2"	IFRSL201GBGUx	single head	2" Female	660	690	1800	1040	790	410
	2 x 2"	IFRSL202IVPEx	multi-head	DN100	630	870	1280	280	270	
		IFRSL202LVPEx			845					
		IFRSL203LVPEx			845					
		IFRSL204LVPEx			1120					
	IFRSL205PFPEx	1520			1315		315	300		
IFRSL206PFPEx	1790									
3"	2 x 3"	IFRSL302LVPEx	DN100	650	870	1290	290	240		
	3 x 3"	IFRSL303PFPEx	DN150	960						
	4 x 3"	IFRSL304PFPEx		1270		1315	315	265		
	5 x 3"	IFRSL305PFPEx		1580						
	6 x 3"	IFRSL305RFPEx	DN200	1600		1335	355	285		
		IFRSL306RFPEx		1890						

Filtration degree (mesh)

x: mesh (replace with:)

Ref.	Mesh	Micron	Colour
H	75	200	
L	120	130	
N	155	100	

Compatible automation kit ACCESSORIES
(to be ordered separately)

Model	No. of Elements x Diameter	KTB	KPB	KFB	KCB	KFA	KCA
RSL 2"	1 x 2"	✓					
	2 x 2"	✓	✓	✓	✓	✓	✓
	3 x 2"	✓	✓	✓	✓	✓	✓
	4 x 2"	✓	✓	✓	✓	✓	✓
	5 x 2"		✓	✓	✓	✓	✓
	6 x 2"		✓	✓	✓	✓	✓
RSL 3"	2 x 3"	✓	✓	✓	✓	✓	✓
	3 x 3"	✓	✓	✓	✓	✓	✓
	4 x 3"	✓	✓	✓	✓	✓	✓
	5 x 3"		✓	✓	✓	✓	✓
	6 x 3"		✓	✓	✓	✓	✓

KTB



Ref.	Description
IFKTB01IM	1 outlet - 12VDC latch
IFKTB02IM	2 outlets - 12VDC latch
IFKTB03IM	3 outlets - 12VDC latch
IFKTB04IM	4 outlets - 12VDC latch

KFB



Ref.	Description
IFKFB02I0	2 outlets - 12VDC latch
IFKFB03I0	3 outlets - 12VDC latch
IFKFB04I0	4 outlets - 12VDC latch
IFKFB05I0	5 outlets - 12VDC latch
IFKFB06I0	6 outlets - 12VDC latch
IFKFB07I0	7 outlets - 12VDC latch
IFKFB08I0	8 outlets - 12VDC latch
IFKFB09I0	9 outlets - 12VDC latch
IFKFB10I0	10 outlets - 12VDC latch

KCB



Ref.	Description
IFKCBS02IM	2 outlets - 12VDC latch
IFKCBS03IM	3 outlets - 12VDC latch
IFKCBS04IM	4 outlets - 12VDC latch
IFKCBS05IM	5 outlets - 12VDC latch
IFKCBS06IM	6 outlets - 12VDC latch
IFKCBS07IM	7 outlets - 12VDC latch

KPB



Ref.	Description
IFKPBS02IM	2 outlets - 12VDC latch
IFKPBS03IM	3 outlets - 12VDC latch
IFKPBS04IM	4 outlets - 12VDC latch
IFKPBS05IM	5 outlets - 12VDC latch
IFKPBS06IM	6 outlets - 12VDC latch
IFKPBS07IM	7 outlets - 12VDC latch
IFKPBS08IM	8 outlets - 12VDC latch

KFA



Ref.	Description
IFKFAU02I0	2 outlets - 24VAC
IFKFAU04I0	4 outlets - 24VAC
IFKFAU06I0	6 outlets - 24VAC
IFKFAU08I0	8 outlets - 24VAC
IFKFAU10I0	10 outlets - 24VAC

KCA



Ref.	Description
IFKCBS02IM	2 outlets - 12VDC latch
IFKCBS03IM	3 outlets - 12VDC latch
IFKCBS04IM	4 outlets - 12VDC latch
IFKCBS05IM	5 outlets - 12VDC latch
IFKCBS06IM	6 outlets - 12VDC latch
IFKCBS07IM	7 outlets - 12VDC latch

DAF

ROTDISK[®]
AUTOMATIC

Description

Rotodisk automatic filter with double filtering element: to implement the backwash system a battery must be assembled, complete with appropriate backwash valves, manifolds and a filter automation kit.

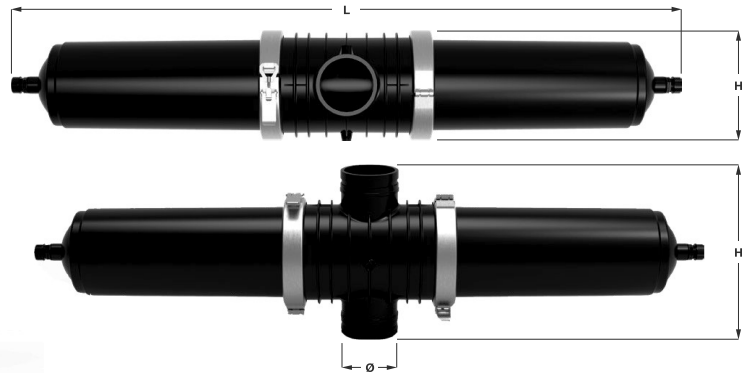

Internal	Code	PN	Max flow rate (m ³ /h)	Filtering Surface (cm ²)	Min pressure backwash (bar)	Min flow rate backwash (m ³ /h)	L (mm)	A (mm)	H (mm)	Weight (kg)
2"	IFDAFLExyyF0N	10	64	2900	2.8	18	1240	250	390	15

General Specifications

CONNECTION TYPE	Male threaded (BSP/NPT and/or Grooved)
FILTERING CARTRIDGE	Automatic
CLOSING SYSTEM	Stainless Steel Clamp
DISCHARGE	Female Thread 3/4" BSP (not perforated)
PRESSURE GAUGE CONNECTIONS	Female threads 1/4" BSP

Connections

yy: connections (replace with:)

Ref.	Type
M2	BSP Male
M5	NPT Male
F0	Flanged
W0	Grooved

Filtration degree (mesh)

x: mesh (replace with:)

Ref.	Mesh	Micron	Colour	No. of Disks per filtering cartridge
H	75	200		560
L	120	130		642
N	155	100		700

Conditions of use

PH RANGE	4<pH<11
MAX TEMPERATURE	60 °C / 140 °F
MAX PRESSURE	10 bar at 20°C

Recommended flow rate (m³/h) according to water quality

Model	Flow rate Maximum	Medium Quality	Poor Quality	Very poor Quality
4"	64	50	38	30

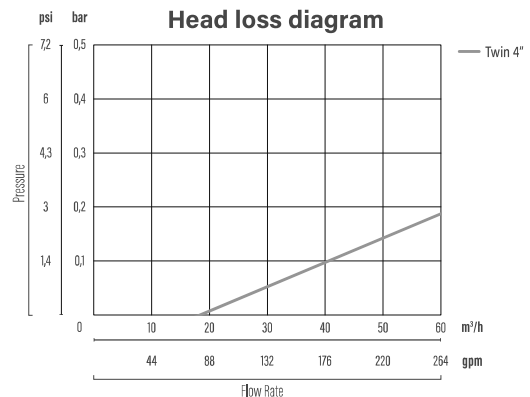
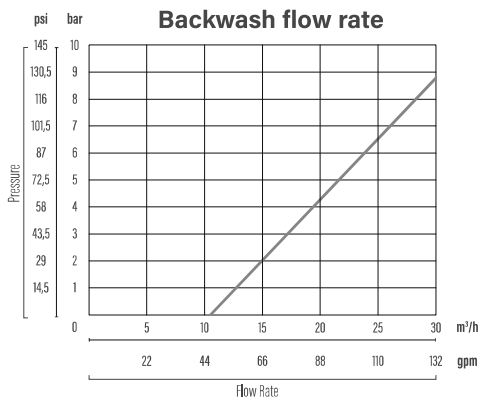

RDL

ROTODISK
AUTOMATIC

Description

DOUBLE HEAD automatic disk filtration batteries. Capable of handling high volumes of water while maintaining great portability and a small footprint. Ideal for large installations (190 - 640 mc/h) on all types of water.



Flow rate
192 - 640 m³/h



Filtering Surface
8700 - 29000 cm²



Diameters
8" - 12"



Filtration Degree (mesh)

Standard filtration degree: 120 mesh

75
(200 micron)

120
(130 micron)

155
(100 micron)

Advantages

- ✓ **Easy to install** and maintain (no tools required for maintenance)
- ✓ Constructed with durable, **high strength plastics**
- ✓ **Small footprint** and highly versatile.



Construction materials

BACKWASH VALVES	Reinforced polyamide
GROOVED COUPLINGS	Cast iron
SUPPORTS	Painted Steel Stainless Steel
MANIFOLDS	High-density polyethylene

Conditions of use

PH RANGE	4<pH<11
MAX TEMPERATURE	60 °C / 140 °F
MAX PRESSURE	10 bar at 20°C

Selecting the correct model

D. MANIFOLDS		8"			10"			12"		
No. OF ELEMENTS PER DIAMETER		3 x 4"	4 x 4"	5 x 4"	6 x 4"	7 x 4"	8 x 4"	9 x 4"	10 x 4"	
MODEL										
General Specifications	CONNECTION TYPE	Flanged								
	FILTRATION DEGREES	75 - 120 - 155 mesh (200 - 130 - 100 micron)								
	BACKWASH VALVE	4" x 4" x 3"								
	MAXIMUM FLOW RATE	192 m ³ /h	256 m ³ /h	320 m ³ /h	384 m ³ /h	448 m ³ /h	512 m ³ /h	576 m ³ /h	640 m ³ /h	
	FILTERING SURFACE	8700 cm ²	11600 cm ²	14500 cm ²	17400 cm ²	20300 cm ²	23200 cm ²	26100 cm ²	29000 cm ²	
	FILTERING CAPACITY	HIGH								
Backwash Data	MINIMUM FLOW RATE	18								
	DISCHARGE MANIFOLDS DIAMETER	DN100								
	MINIMUM PRESSURE	2.8 bar								
	MIN TIME BACKWASH	20 - 30 sec.								
	WASH CRITERIA	ΔP max 0.5 bar - washing cycles according to water quality								
Applications	 AGRICULTURE	Primary filtration on medium to large sized systems (water quality from POOR to GOOD) Secondary filtration on "problematic" water (water with high lime and clay content)								
	 LANDSCAPE	Main filtration on large sized systems (parks, public green spaces, golf courses etc.)								

Head loss diagram
(single filtering element)

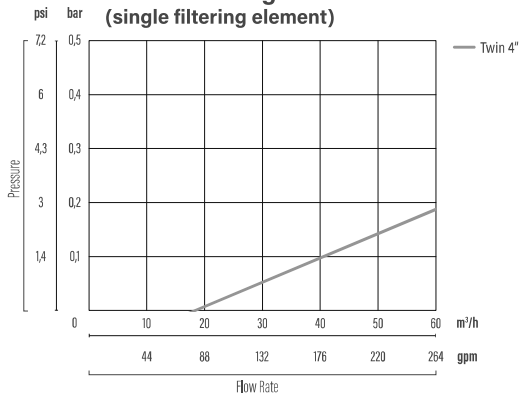

Recommended flow rate (m³/h)
according to water quality

Model	Configuration	Flow rate Maximum	Medium Quality	Poor Quality	Very poor Quality
RDL	3 x 4"	192	150	114	90
	4 x 4"	256	200	152	120
	5 x 4"	320	250	190	150
	6 x 4"	384	300	228	180
	7 x 4"	448	350	266	210
	8 x 4"	512	400	304	240
	9 x 43"	576	450	342	270
	10 x 4"	640	500	380	300

RDL

ROTODISK
AUTOMATIC

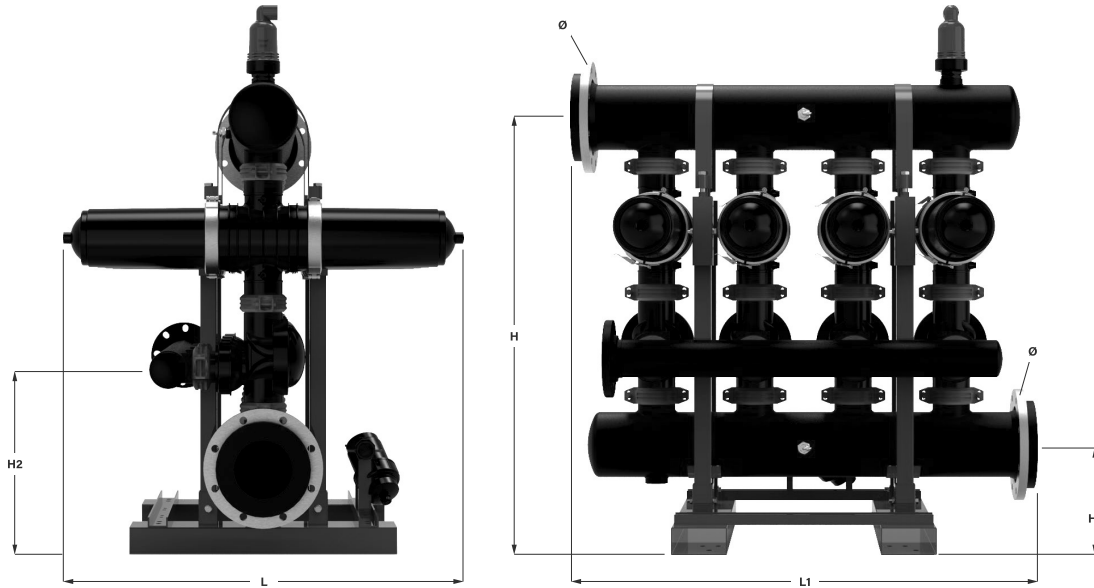

Model	No. of Elements per diameter	Code	Off-take	L (mm)	L1 (mm)	H (mm)	H1 (mm)	H2 (mm)
4"	3 x 4"	IFRDL403RFPEX	DN200	1240	1120	1185	285	630
	4 x 4"	IFRDL404RFPEX			1420			
	5 x 4"	IFRDL405TFPEX			1720			
	6 x 4"	IFRDL406TFPEX	DN250		2020	1235	310	680
	7 x 4"	IFRDL407TFPEX			2320			
	8 x 4"	IFRDL408VFPEX	DN300		2620	1310	350	750
	9 x 4"	IFRDL409VFPEX			2920			
	10 x 4"	IFRDL4010VFPEX			3220			

Filtration degree (mesh)

x: mesh (replace with:)

Ref.	Mesh	Micron	Colour
H	75	200	
L	120	130	
N	155	100	

Compatible automation kit ACCESSORIES
(to be ordered separately)

Model	No. of Elements x Diameter	KTB	KPB	KFB	KCB	KFA	KCA
RDL 4"		Latch Solenoids				24V Solenoids	
	3 x 4"	✓	✓	✓	✓	✓	✓
	4 x 4"	✓	✓	✓	✓	✓	✓
	5 x 4"		✓	✓	✓	✓	✓
	6 x 4"		✓	✓	✓	✓	✓
	7 x 4"			✓	✓	✓	✓
	8 x 4"			✓	✓	✓	✓
	9 x 4"			✓	✓	✓	✓
10 x 4"			✓	✓	✓	✓	



Ref.	Description
IFKTBS01IM	1 outlet - 12VDC latch
IFKTBS02IM	2 outlets - 12VDC latch
IFKTBS03IM	3 outlets - 12VDC latch
IFKTBS04IM	4 outlets - 12VDC latch



Ref.	Description
IFKFS02IO	2 outlets - 12VDC latch
IFKFS03IO	3 outlets - 12VDC latch
IFKFS04IO	4 outlets - 12VDC latch
IFKFS05IO	5 outlets - 12VDC latch
IFKFS06IO	6 outlets - 12VDC latch
IFKFS07IO	7 outlets - 12VDC latch
IFKFS08IO	8 outlets - 12VDC latch
IFKFS09IO	9 outlets - 12VDC latch
IFKFS10IO	10 outlets - 12VDC latch



Ref.	Description
IFKCBS02IM	2 outlets - 12VDC latch
IFKCBS03IM	3 outlets - 12VDC latch
IFKCBS04IM	4 outlets - 12VDC latch
IFKCBS05IM	5 outlets - 12VDC latch
IFKCBS06IM	6 outlets - 12VDC latch
IFKCBS07IM	7 outlets - 12VDC latch



Ref.	Description
IFKPBS02IM	2 outlets - 12VDC latch
IFKPBS03IM	3 outlets - 12VDC latch
IFKPBS04IM	4 outlets - 12VDC latch
IFKPBS05IM	5 outlets - 12VDC latch
IFKPBS06IM	6 outlets - 12VDC latch
IFKPBS07IM	7 outlets - 12VDC latch
IFKPBS08IM	8 outlets - 12VDC latch



Ref.	Description
IFKFAU02IO	2 outlets - 24VAC
IFKFAU04IO	4 outlets - 24VAC
IFKFAU06IO	6 outlets - 24VAC
IFKFAU08IO	8 outlets - 24VAC
IFKFAU10IO	10 outlets - 24VAC



Ref.	Description
IFKCBS02IM	2 outlets - 12VDC latch
IFKCBS03IM	3 outlets - 12VDC latch
IFKCBS04IM	4 outlets - 12VDC latch
IFKCBS05IM	5 outlets - 12VDC latch
IFKCBS06IM	6 outlets - 12VDC latch
IFKCBS07IM	7 outlets - 12VDC latch

Filtration | Metal filters

Irritec's line of metal filters offers complete and extremely robust solutions. The product range is divided into sand media filters, screen filters (both traditional and semi-automatic versions) and hydrocyclone sand separators. The special care taken in the construction and the use of high thickness metal make this filter line the

right solution for the toughest applications and the most difficult waters. Irritec metal filters are also protected by a thick Epoxy paint that protects the metal from corrosive events over a long period of time.





SAND MEDIA FILTERS

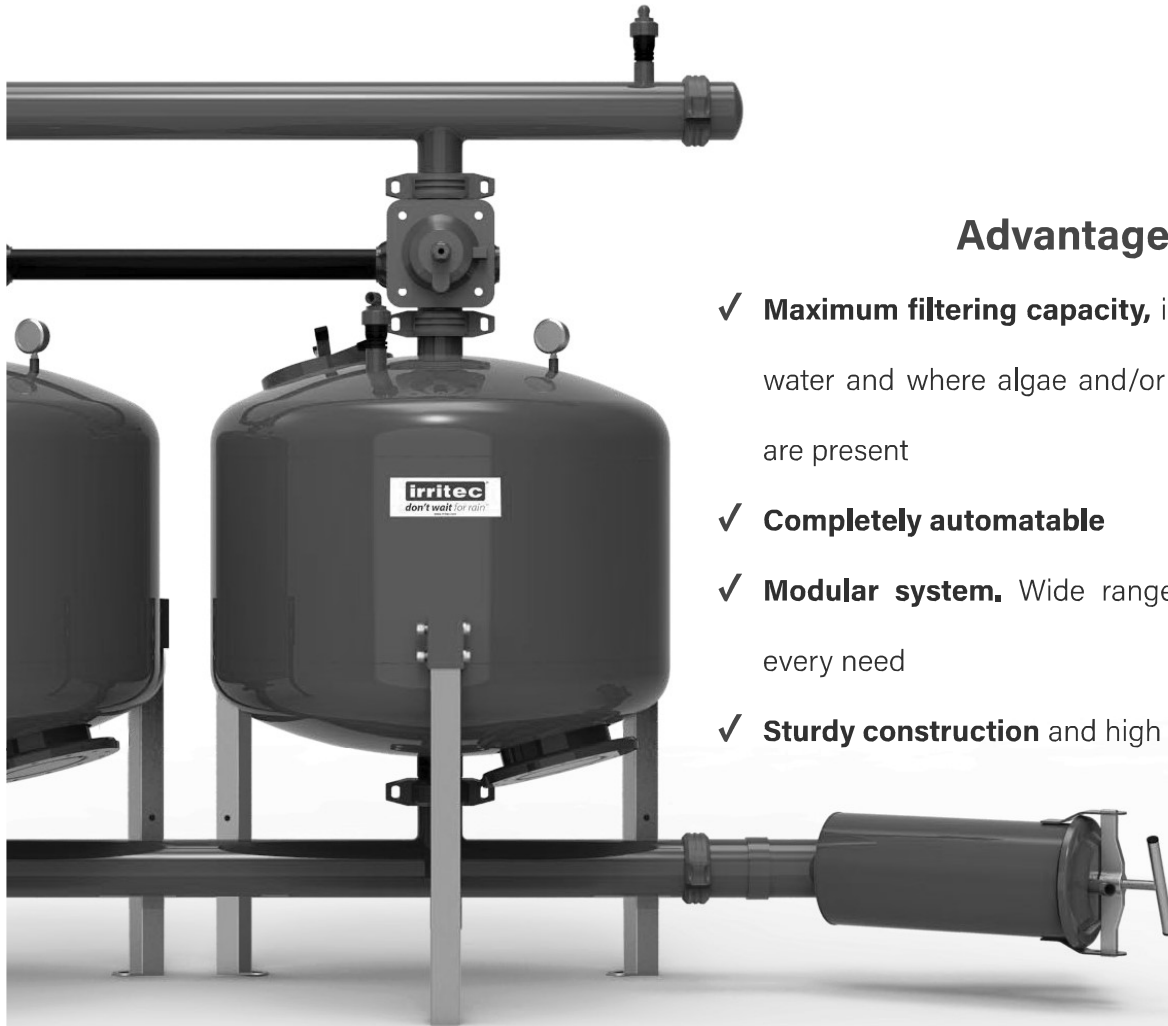

Advantages

- ✓ **Maximum filtering capacity**, ideal for poor quality water and where algae and/or organic substances are present
- ✓ **Completely automatable**
- ✓ **Modular system**. Wide range of models to suit every need
- ✓ **Sturdy construction** and high quality coating

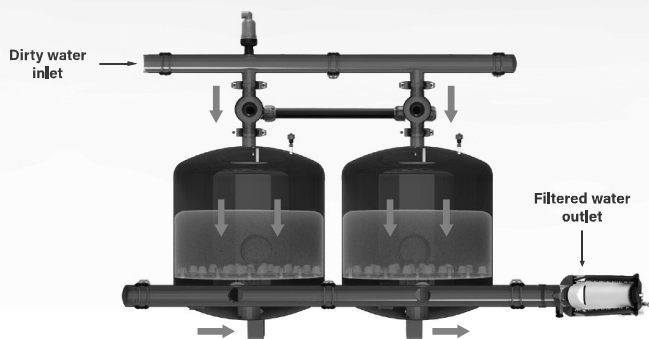

Filtration

Dirty water flows through the sand "filter beds". Impurities in the water remain trapped inside.

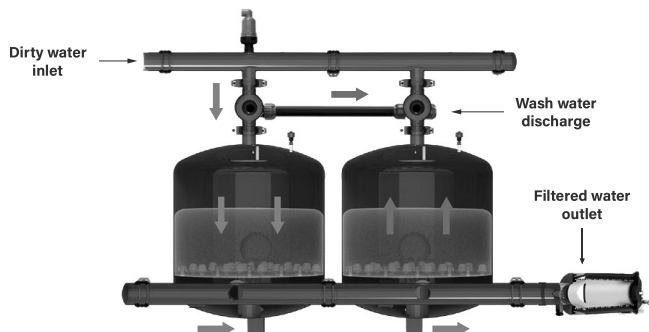

Backwash

Reversing the flow through a filtering element causes the sand bed to expand. Accumulated impurities are expelled during "backwashing" through the discharge manifold. The wash cycle ends after repeating this operation for each filtering element.

SAND MEDIA FILTERS

PRODUCT RANGE: Single element and complete batteries



EUV

- Sand media filtering element with drainage consisting of a plate and "mushroom" diffusers
- Diameters from 320 to 1200 mm - connections from 1" - 4"
- Maximum filtration and wash efficiency



GCV

- Complete filter batteries, consisting of multiple EUV elements and completed with back-up filter and manifolds
- Modular system for any application

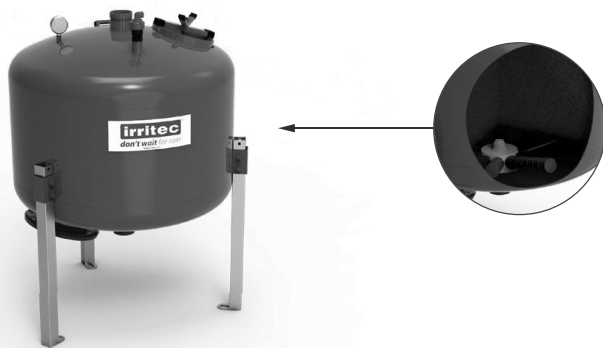

ECV

- Sand media filtering element with drainage consisting of radial arm manifold and "maxi flow" diffusers
- Diameters from 600 to 1200 mm - Connections from 2" - 4"
- Compact, lightweight structure, retractable supports

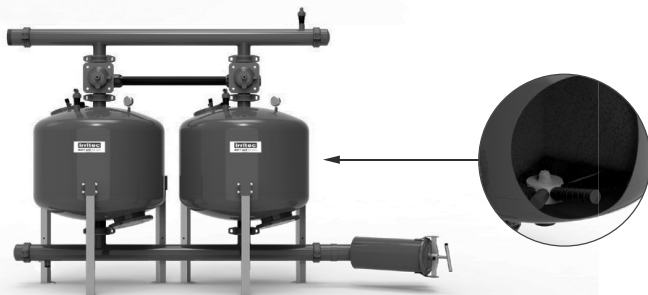

HCV

- Complete filtration batteries, consisting of multiple ECV elements. Complete with back-up filter and manifolds.
- Modular system for any capacity.
- Lighter and more compact design than GCV but same build quality.

EUV

**SAND MEDIA
 FILTERS**

Description

Sand media filter with "plate" and "mushroom" diffuser drainage. Made of high gauge metal and protected by a high quality epoxy paint. Ideal for treating difficult waters (high turbidity, presence of algae and other organic residues).



Flow rate
 3 - 90 m³/h



Filtering Surface
 800 - 11300 cm²



Diameters
 1" - 4"



Advantages

- ✓ Drainage system (plate) with **very high efficiency** in both the filtration and wash stages
- ✓ **Sturdy construction** with high element metal.
- ✓ **Large, easy to open, oval inspection** and load hatches

Construction materials

FILTER BODY	Structural steel
MANIFOLDS	Structural steel
COATING	Polyester powder coating (min. thickness 160 micron)
DIFFUSERS	Polypropylene
FILTERING ELEMENT	Sand (recommended grain size: 0.8 - 1.2 mm)
GASKETS	EPDM
ACCESSORIES	Polypropylene



Conditions of use

PH RANGE	4 < pH < 11
MAX TEMPERATURE	60 °C / 140 °F
MAX PRESSURE	8 bar at 20°C
MIN BACKWASH PRESSURE	2.5 bar

EUV

**SAND MEDIA
FILTERS**

Selecting the correct model

BODY DIAMETER	320 mm	400 mm (16")	500 mm (20")	600 mm (24")	900 mm (36")	1200 mm (48")
CONNECTIONS	1"	1 1/2"	2"		3"	4"
MODEL	Type A				Type B	
						

General Specifications	CONNECTION TYPE	Threaded Female			Threaded Female - Flanged - Grooved		
	FILTERING SURFACE	800 cm ²	1300 cm ²	2000 cm ²	2800 cm ²	6400 cm ²	11300 cm ²
	QUANTITY OF SAND	40 kg	75 kg	100 kg	150 kg	350 kg	800 kg
	MAXIMUM FLOW RATE	6 m ³ /h	11 m ³ /h	18 m ³ /h	28 m ³ /h	62 m ³ /h	90 m ³ /h
	FILTERING CAPACITY	VERY HIGH					

Backwash Data	MINIMUM FLOW RATE	3 m ³ /h	5 m ³ /h	8 m ³ /h	11 m ³ /h	25 m ³ /h	45 m ³ /h
	MINIMUM PRESSURE	2.5 bar					
	MIN TIME BACKWASH	60 - 120 sec.					
	BACKWASH CRITERIA	ΔP max 0.5 bar - washing cycles according to water quality					

Applications	 AGRICULTURE	Primary filtration of "Difficult" water - medium-large systems
	 LANDSCAPE	

EUV

**SAND MEDIA
FILTERS**

Type A

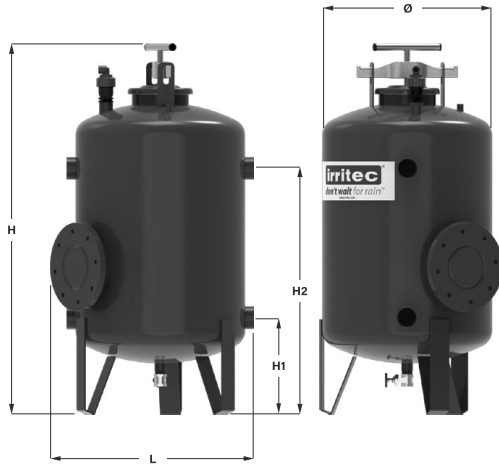

Type B

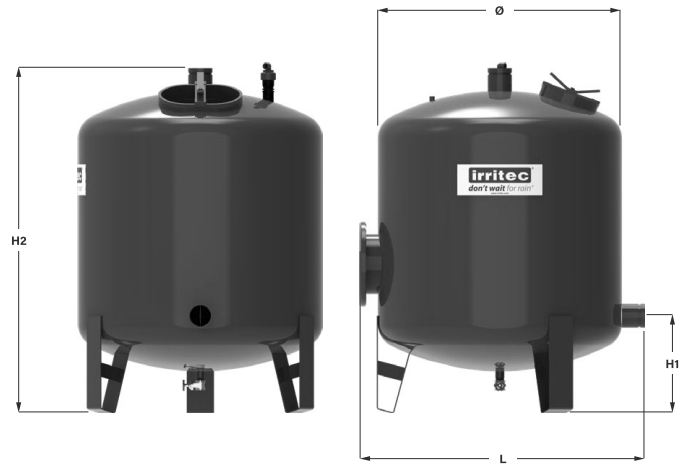

Ø body (mm)	Connections		Code	Type	Number of Nozzles	Flow rate (m³/h)	L (mm)	H1 (mm)	H2 (mm)	Weight (kg)
320	1"	threaded female	IFEUV10H320	-	9	3÷6	320	70	640	35
400	1 1/2"	threaded female	IFEUV15H400	Type A	12	6÷11	450	275	670	43
500	2"	threaded female	IFEUV20H500		15	9÷18	550	340	835	60
600		threaded female	IFEUV20H600		21	14÷28	650	370		70
900	3"	threaded female	IFEUV30H600			52	32÷62		670	400
		grooved	IFEUV30W900	1070	1275					
		flanged	IFEUV30F900	1080	1285			157		
	4"	threaded female	IFEUV40H900	88	35÷65		1050	440	1285	
flanged		IFEUV40F900	1080			1285	160			
1200		threaded female	IFEUV40H1200			35÷90	1350		440	1365
	grooved	IFEUV40W1200	1370	1385						
		flanged	IFEUV40F1200			1380		1400	242	

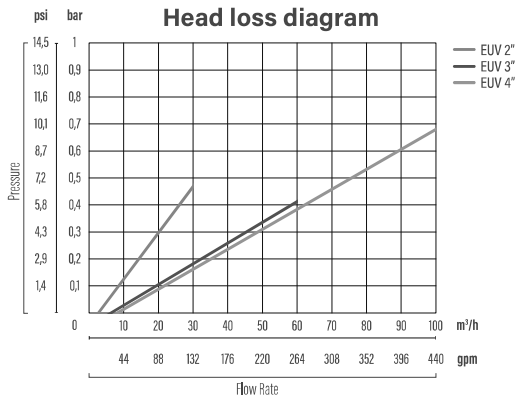
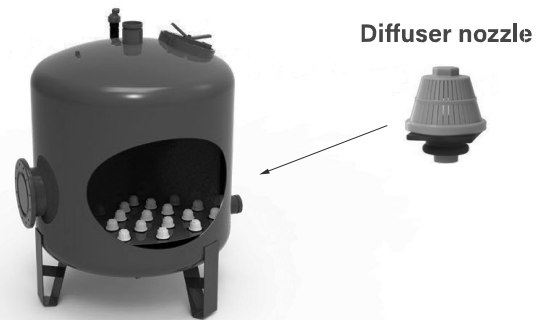

Recommended flow rate (m³/h) according to water quality

Model	Body Diameter	Flow rate Maximum	Medium Quality	Poor Quality	Very poor Quality
EUV	320	6	5	4	3
	400	11	8	6	5
	500	18	12	10	8
	600	28	17	14	11
	900	62	40	30	25
	1200	90	70	55	45

GCV Complete filtration batteries

SAND MEDIA FILTERS

Description

Complete filtration battery consisting of EUV filtering elements, back-up filter, inlet & outlet manifolds, PE discharge manifold, 3-way backwash valves and accessories - automation kit not included (can be ordered separately),



Selecting the correct model

CONFIGURATION	IN LINE									IN PARALLEL						
	600 mm			900 mm			1200 mm			900 mm			1200 mm			
TANKS DIAMETER	600 mm			900 mm			1200 mm			900 mm			1200 mm			
NUMBER OF ELEMENTS	2	3	4	2	3	4	2	3	4	4	5	6	4	5	6	
BACK-UP FILTER	1 x 3"		1 x 4"		1 x 6"		1 x 8"		2 x 6"		1 x 6"		2 x 6"		3 x 6"	
TYPE OF BACK-UP FILTER	EPV															
CONNECTIONS	3"		4"		DN150		DN200		DN150		DN200		DN250			

General Specifications	CONNECTION TYPE	Threaded Female						Flanged								
	NOMINAL PRESSURE	8 bar														
	FILTERING SURFACE (cm ²)	5600	8400	11200	12800	19200	25600	22600	33900	45200	25600	32000	38400	45200	56500	67800
	QUANTITY OF SAND (kg)	300	450	600	700	1050	1400	1600	2400	3200	1400	1750	2100	3200	4000	4800
	NOMINAL FLOW RATE (m ³ /h)	40	60	80	80	120	160	140	210	280	160	200	250	280	350	420

Compatible automation kits (to be ordered separately)

Number of Filters	KTB	KPB	KFB	KCB	KFA	KCA
1	✓	✓	✓	✓	✓	✓
2	✓	✓	✓	✓	✓	✓
3	✓	✓	✓	✓	✓	✓
4	✓	✓	✓	✓	✓	✓
5		✓	✓	✓	✓	✓
6			✓	✓	✓	✓



Ref.	Description
IFKFB02I0	2 outlets - 12VDC latch
IFKFB03I0	3 outlets - 12VDC latch
IFKFB04I0	4 outlets - 12VDC latch
IFKFB05I0	5 outlets - 12VDC latch
IFKFB06I0	6 outlets - 12VDC latch
IFKFB07I0	7 outlets - 12VDC latch
IFKFB08I0	8 outlets - 12VDC latch
IFKFB09I0	9 outlets - 12VDC latch
IFKFB10I0	10 outlets - 12VDC latch



Ref.	Description
IFKTB01I0	1 outlet - 12VDC latch
IFKTB02I0	2 outlets - 12VDC latch
IFKTB03I0	3 outlets - 12VDC latch
IFKTB04I0	4 outlets - 12VDC latch



Ref.	Description
IFKCBS02I0	2 outlets - 12VDC latch
IFKCBS03I0	3 outlets - 12VDC latch
IFKCBS04I0	4 outlets - 12VDC latch
IFKCBS05I0	5 outlets - 12VDC latch
IFKCBS06I0	6 outlets - 12VDC latch
IFKCBS07I0	7 outlets - 12VDC latch



Ref.	Description
IFKPB02I0	2 outlets - 12VDC latch
IFKPB03I0	3 outlets - 12VDC latch
IFKPB04I0	4 outlets - 12VDC latch
IFKPB05I0	5 outlets - 12VDC latch
IFKPB06I0	6 outlets - 12VDC latch
IFKPB07I0	7 outlets - 12VDC latch
IFKPB08I0	8 outlets - 12VDC latch



Ref.	Description
IFKFAU02I0	2 outlets - 24VAC
IFKFAU04I0	4 outlets - 24VAC
IFKFAU06I0	6 outlets - 24VAC
IFKFAU08I0	8 outlets - 24VAC
IFKFAU10I0	10 outlets - 24VAC



Ref.	Description
IFKCBS02I0	2 outlets - 12VDC latch
IFKCBS03I0	3 outlets - 12VDC latch
IFKCBS04I0	4 outlets - 12VDC latch
IFKCBS05I0	5 outlets - 12VDC latch
IFKCBS06I0	6 outlets - 12VDC latch
IFKCBS07I0	7 outlets - 12VDC latch

GCV

**SAND MEDIA
FILTERS**

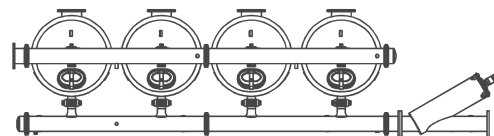
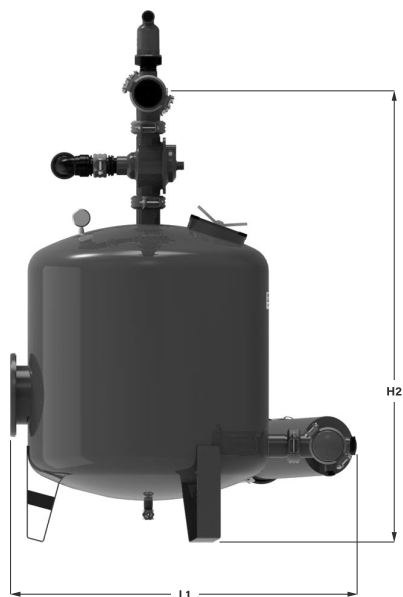

GCV "In line" models

Configuration	Code	Nominal flow rate (m ³ /h)	Connections		L (mm)	L1 (mm)	H (mm)	H1 (mm)
2 x 600	IFGCV6202PIHI	40	3"	threaded female	2700	1150	835	370
3 x 600	IFGCV6203PLHI	60			3600			
4 x 600	IFGCV6204PLHI	80			4400			
2 x 900	IFGCV9302PLHI	80	4"	threaded female	3200	1200	1680	400
3 x 900	IFGCV9303PPFI	120			4500		1710	
4 x 900	IFGCV9304PPFI	160			5500		1710	
2 x 1200	IFGCV1402PPFI	140	DN 150	flanged	4100	1500	1833	440
3 x 1200	IFGCV1403PRFI	210			5000		1865	
4 x 1200	IFGCV1404PRFI	280			6600		1865	

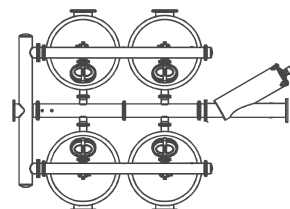

GCV "In parallel" models

Configuration	Code	Nominal flow rate (m ³ /h)	Connections		L (mm)	L1 (mm)	H (mm)	H1 (mm)
4 x 900	IFGCV9304PPFU	160	DN 150	flanged	3700	2640	1680	400
5 x 900	IFGCV9305PRFU	200	DN 200		5000	2700	1710	
6 x 900	IFGCV9306PRFU	250			5500			
4 x 1200	IFGCV1404PRFU	280	DN 250	flanged	5100	3280	1865	440
5 x 1200	IFGCV1405PTFU	350			6200			
6 x 1200	IFGCV1406PTFU	420			6800			

ECV

**SAND MEDIA
FILTERS**

Description

Sand media filter with radial arm and "maxi-flow" diffuser drainage. Made of high gauge metal and protected by a high quality epoxy paint. Ideal for treating difficult waters (high turbidity, presence of algae and other organic residues)



Flow rate
14 - 90 m³/h



Filtering Surface
2800 - 11300 cm²



Diameters
2" - 4"

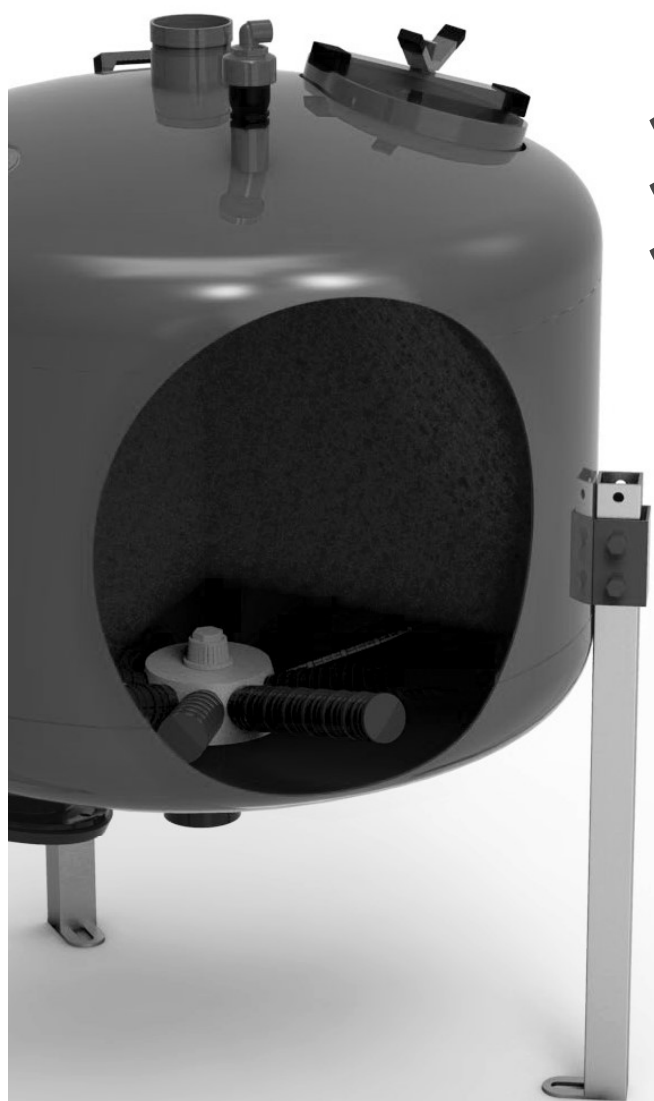

Advantages

- ✓ **Lightweight, compact design** – retractable supports
- ✓ **Sturdy construction** with high gauge metal.
- ✓ Large, easy to open, oval inspection **and load hatches**





Construction materials

FILTER BODY	Structural steel
MANIFOLDS	Structural steel
COATING	Polyester powder coating (min. thickness 160 micron)
DIFFUSERS	Polypropylene
FILTERING ELEMENT	Sand (recommended grain size: 0.8 - 1.2 mm)
GASKETS	EPDM
ACCESSORIES	Polypropylene

Conditions of use

PH RANGE	4<pH<11
MAX TEMPERATURE	60 °C / 140 °F
MAX PRESSURE	8 bar at 20°C
MIN BACKWASH PRESSURE	2.5 bar

Selecting the correct model

MODEL	600 (24")	750 (30")	900 (36")	1200 (48")
CONNECTIONS	2"		3"	4"
MODEL	Type A 		Type B 	
General Specifications	CONNECTION TYPE	Threaded Female		Threaded Female - Flanged - Grooved
	FILTERING SURFACE	2800 cm ²	4400 cm ²	6400 cm ² 11300 cm ²
	QUANTITY OF SAND	150 kg	200 kg	350 kg 800 kg
	MAXIMUM FLOW RATE	28 m ³ /h	42 m ³ /h	62 m ³ /h 90 m ³ /h
	FILTERING CAPACITY	VERY HIGH		
Backwash Data	MINIMUM FLOW RATE	11 m ³ /h	18 m ³ /h	25 m ³ /h 45 m ³ /h
	MINIMUM PRESSURE	2.5 bar		
	MIN TIME BACKWASH	60 - 120 sec.		
	BACKWASH CRITERIA	ΔP max 0.5 bar - washing cycles according to water quality		
Applications	 AGRICULTURE	Primary filtration of "Difficult" water		
	 LANDSCAPE			

ECV

**SAND MEDIA
FILTERS**

Type A

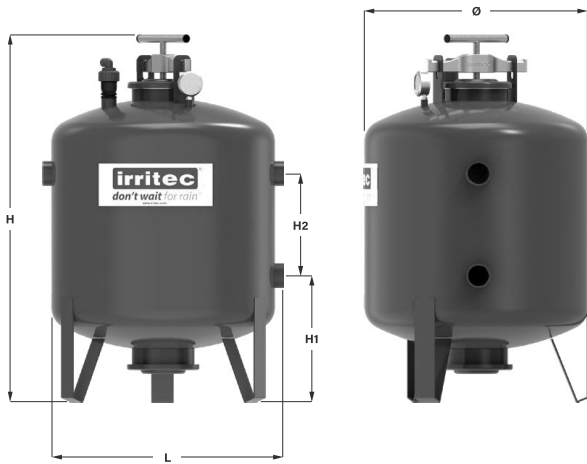

Type B

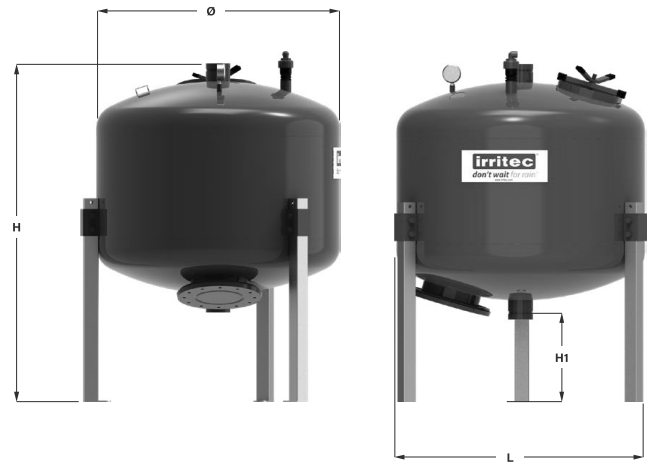

Ø body (mm)	Connections		Code	Type	Number Nozzles	Length Nozzles (mm)	Flow rate (m³/h)	L (mm)	H (mm)	H1 (mm)	H2 (mm)	Weight (kg)						
600	2"	threaded female	IFECV20H600	Type A	6	237	14÷28	650	1000	335	275	70						
750		threaded female	IFECV20H750															
900	3"	threaded female	IFECV30H900	Type B	8	347	32÷62	960	1265	300	-	110						
		grooved	IFECV30W900						1245									
		flanged	IFECV30F900						1200									
1200	4"	threaded female	IFECV40H1200						16			493	35÷90	1320	1340	300	-	220
		grooved	IFECV40W1200												1300			
		flanged	IFECV40F1200												1270			370

Diffuser nozzle

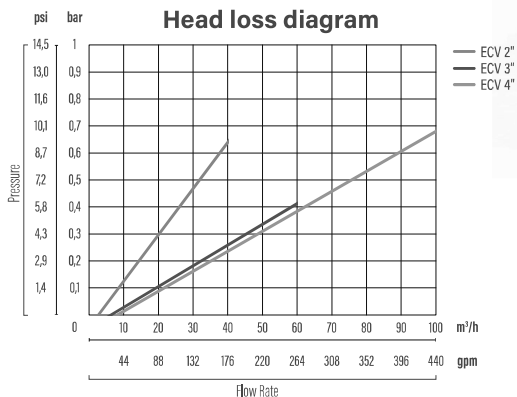
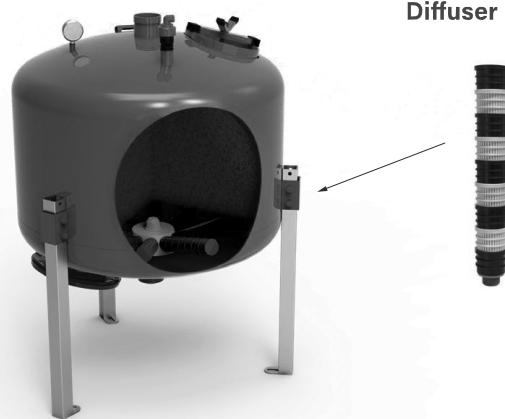

Recommended flow rate (m³/h) according to water quality

Model	Body Diameter	Flow rate Maximum	Medium Quality	Poor Quality	Very poor Quality
ECV	600	28	17	14	11
	750	42	26	22	18
	900	62	40	30	25
	1200	90	70	55	45

HCV Complete filtration batteries

SAND MEDIA FILTERS

Description

Complete filtration battery consisting of ECV filtering elements, mesh back-up filter, inlet & outlet manifolds, PE discharge manifold, 3-way backwash valves and accessories - automation kit not included (can be ordered separately).



Selecting the correct model

CONFIGURATION	IN LINE									IN PARALLEL				
TANKS DIAMETER	600 mm			900 mm			1200 mm			900 mm		1200 mm		
NUMBER OF ELEMENTS	2	3	4	2	3	4	2	3	4	4	6	4	6	
BACK-UP FILTER	1 x 3"		1 x 4"			1 x 6"			1 x 8"	2 x 6"	1 x 6"	2 x 6"		3 x 6"
TYPE OF BACK-UP FILTER	EPV													
CONNECTIONS	3"		4"			DN150			DN200		DN150	DN200		DN250

General Specifications	CONNECTION TYPE	Threaded Female						Flanged					
	NOMINAL PRESSURE	8 bar											
FILTERING SURFACE (cm ²)	5600	8400	11200	12800	19200	25600	22600	33900	45200	25600	38400	45200	67800
QUANTITY OF SAND (kg)	300	450	600	700	1050	1400	1600	2400	3200	1400	2100	3200	4800
NOMINAL FLOW RATE (m ³ /h)	40	60	80	80	120	160	140	210	280	160	250	280	420

Compatible automation kit ACCESSORIES (to be ordered separately)

Number of Filters	KTB	KPB	KFB	KCB	KFA	KCA
	Latch Solenoids				24V Solenoids	
1	✓	✓	✓	✓	✓	✓
2	✓	✓	✓	✓	✓	✓
3	✓	✓	✓	✓	✓	✓
4	✓	✓	✓	✓	✓	✓
5		✓	✓	✓	✓	✓
6			✓	✓	✓	✓



Ref.	Description
IFKFB02I0	2 outlets - 12VDC latch
IFKFB03I0	3 outlets - 12VDC latch
IFKFB04I0	4 outlets - 12VDC latch
IFKFB05I0	5 outlets - 12VDC latch
IFKFB06I0	6 outlets - 12VDC latch
IFKFB07I0	7 outlets - 12VDC latch
IFKFB08I0	8 outlets - 12VDC latch
IFKFB09I0	9 outlets - 12VDC latch
IFKFB10I0	10 outlets - 12VDC latch



Ref.	Description
IFKTBS01IM	1 outlet - 12VDC latch
IFKTBS02IM	2 outlets - 12VDC latch
IFKTBS03IM	3 outlets - 12VDC latch
IFKTBS04IM	4 outlets - 12VDC latch



Ref.	Description
IFKCBS02IM	2 outlets - 12VDC latch
IFKCBS03IM	3 outlets - 12VDC latch
IFKCBS04IM	4 outlets - 12VDC latch
IFKCBS05IM	5 outlets - 12VDC latch
IFKCBS06IM	6 outlets - 12VDC latch
IFKCBS07IM	7 outlets - 12VDC latch



Ref.	Description
IFKCBS02IM	2 outlets - 12VDC latch
IFKCBS03IM	3 outlets - 12VDC latch
IFKCBS04IM	4 outlets - 12VDC latch
IFKCBS05IM	5 outlets - 12VDC latch
IFKCBS06IM	6 outlets - 12VDC latch
IFKCBS07IM	7 outlets - 12VDC latch



Ref.	Description
IFKPBS02IM	2 outlets - 12VDC latch
IFKPBS03IM	3 outlets - 12VDC latch
IFKPBS04IM	4 outlets - 12VDC latch
IFKPBS05IM	5 outlets - 12VDC latch
IFKPBS06IM	6 outlets - 12VDC latch
IFKPBS07IM	7 outlets - 12VDC latch
IFKPBS08IM	8 outlets - 12VDC latch



Ref.	Description
IFKFAU02I0	2 outlets - 24VAC
IFKFAU04I0	4 outlets - 24VAC
IFKFAU06I0	6 outlets - 24VAC
IFKFAU08I0	8 outlets - 24VAC
IFKFAU10I0	10 outlets - 24VAC

HCV SAND MEDIA FILTERS

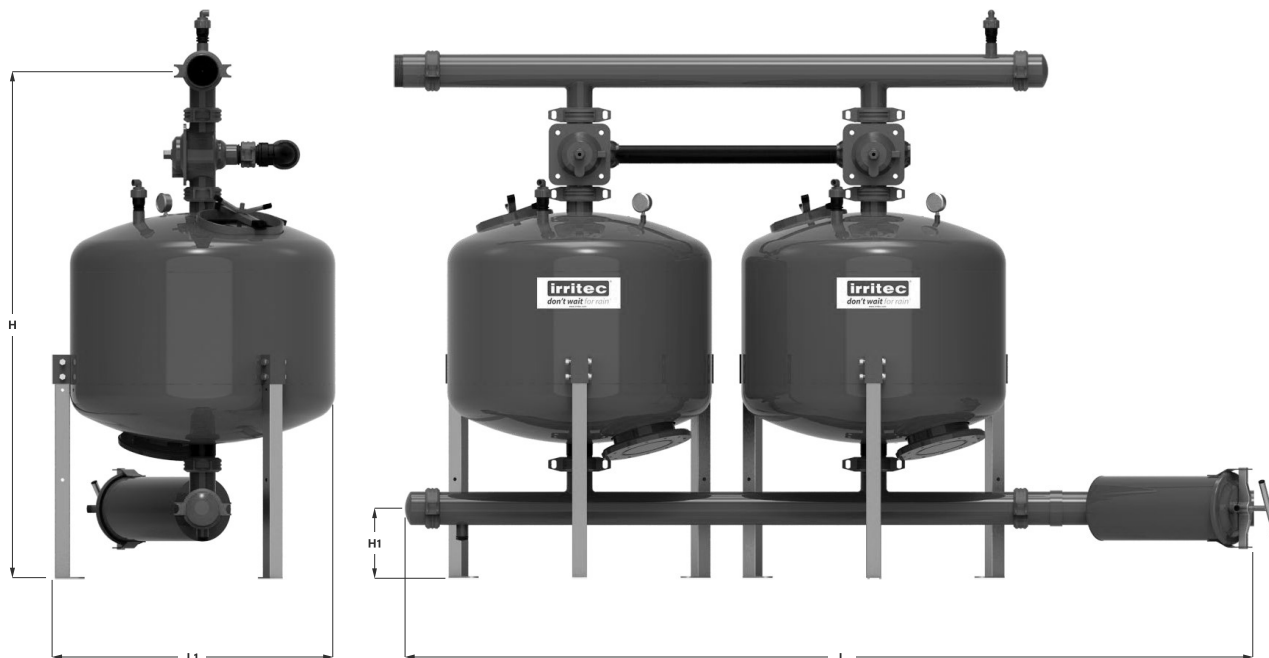

HCV "In line" models

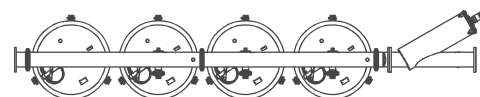

Configuration	Code	Nominal flow rate (m³/h)	Connections		L (mm)	L1 (mm)	H (mm)	H1 (mm)	
2 x 600	IFHCV6202PIHI	40	3"	threaded female	2700	1150	610	335	
3 x 600	IFHCV6203PLHI	60			4"				3600
4 x 600	IFHCV6204PLHI	80							4400
2 x 900	IFHCV9302PLHI	80	DN 150	flanged	3200	1200	1510	180	
3 x 900	IFHCV9303PPFI	120			4500		1570	210	
4 x 900	IFHCV9304PPFI	160			5500	1615			
2 x 1200	IFHCV1402PPFI	140	DN 200	flanged	4100	1500	1710	270	
3 x 1200	IFHCV1403PRFI	210			5000				
4 x 1200	IFHCV1404PRFI	280			6600				

HCV "In parallel" models

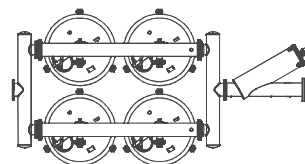

Configuration	Code	Nominal flow rate (m³/h)	Connections		L (mm)	L1 (mm)	H (mm)	H1 (mm)
4 x 900	IFGCV9304PPFU	160	DN 150	flanged	3700	2640	1570	210
6 x 900	IFGCV9306PRFU	250	DN 200		4660	2700	1710	270
4 x 1200	IFGCV1404PRFU	280			4260	3280		
6 x 1200	IFGCV1406PTFU	420	DN 250		6800	3340	1740	310

M10 Flanged/grooved adapter

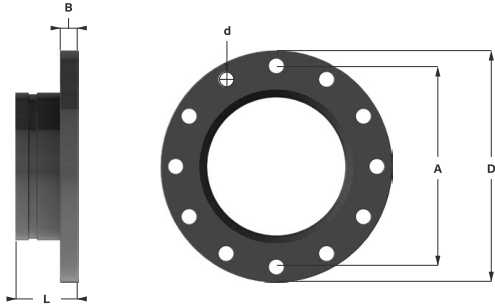

Connections	Code	L (mm)	D (mm)	A (mm)	B (mm)	No. of holes	d (mm)	Weight (kg)
DN 80 - 3"	IFM10V03F03V	110	200	160	20	8	18	5
DN 80 - 4"	IFM10V03F04V	260	200	160	20	8	18	5
DN 100 - 3"	IFM10V04F03V	260	220	180	22	8	18	6
DN 100 - 4"	IFM10V04F04V	110	220	180	22	8	18	6
DN 150 - 6"	IFM10V06F06V	110	285	240	24	8	22	8
DN 200 - 8"	IFM10V08F08V	90	340	295	24	8	22	10

M11 Flanged adapter/female threaded

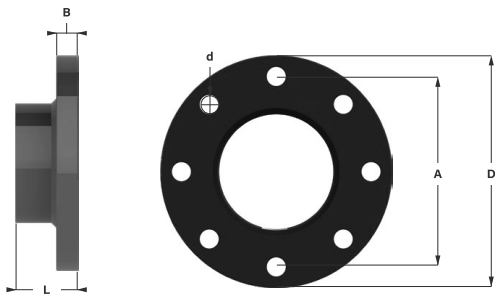

Connections	Code	L (mm)	D (mm)	A (mm)	B (mm)	No. of holes	d (mm)	Weight (kg)
DN 80 - 3"	IFM11V03F03H	55	200	160	20	8	18	5
DN 100 - 4"	IFM11V04F04H	60	220	180	22	8	18	5
DN 125 - 4"	IFM11V05F04H	180	250	210	22	8	18	9
DN 125 - 5"	IFM11V05F05H	65	250	210	22	8	18	6

M14 Grooved plug



Connections	Code	L (mm)	Weight (kg)
2"	IFM14V02	125	0.9
3"	IFM14V03	130	1.1
4"	IFM14V04	135	1.9
6"	IFM14V06	145	2.6
8"	IFM14V08	170	3.2

M16 Flanged adapter

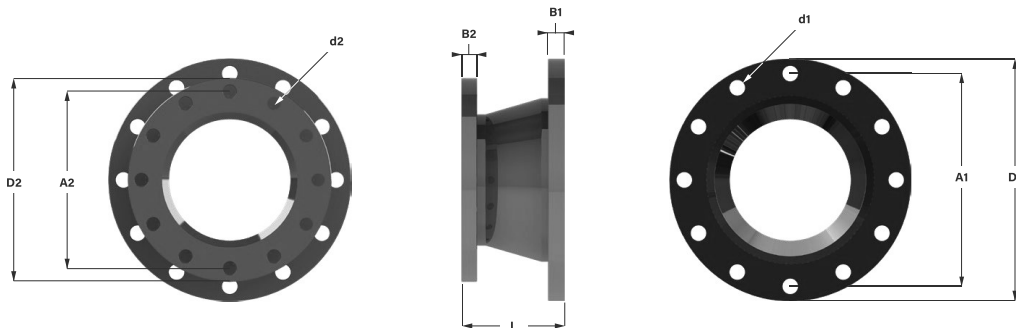

Connections	Code	L1 (mm)	D1 (mm)	A1 (mm)	B1 (mm)	No. of holes 1	d1 (mm)	D2 (mm)	A2 (mm)	B2 (mm)	No. of holes 2	d2 (mm)	Weight (kg)
DN 100 - DN 80	IFM16V04F03F	120	220	180	22	8	18	200	160	20	8	18	10
DN 125 - DN 100	IFM16V05F04F	150	250	210	22	8	18	220	180	22	8	18	11
DN 150 - DN 100	IFM16V06F04F	160	285	240	24	8	22	220	180	22	8	18	13
DN 150 - DN 125	IFM16V06F05F	160	285	240	24	8	22	250	210	22	8	18	15
DN 200 - DN 150	IFM16V08F06F	160	340	295	24	8	22	285	240	24	8	22	20
DN 250 - DN 200	IFM16V10F08F	160	395	350	26	12	22	340	295	24	8	22	25

M21 Grooved adapter/female threaded

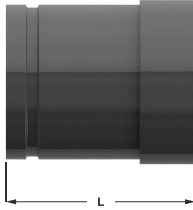

Connections	Code	L (mm)	Weight (kg)
2"	IFM21V02H02V	130	1.1
3"	IFM21V03H03V	135	1.3
4"	IFM21V04H04V	145	1.9

M22 Grooved adapter/female threaded

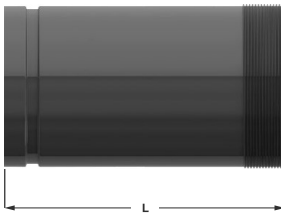

Connections	Code	L (mm)	Weight (kg)
2"	IFM22V02M02V	200	1.5
3"	IFM22V03M03V	200	1.6
4"	IFM22V04M04V	200	1.8

FCV Single outlet manifold with threaded outlets for pressure tapping and venting

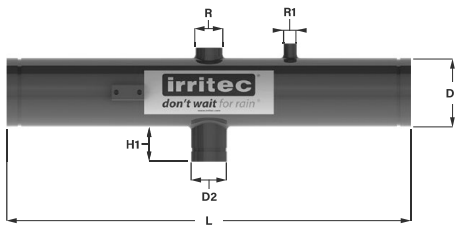

D1 (inch)		D2 (inch)		Code	H1 (mm)	R (inch)	R1 (inch)	L (mm)	Weight (kg)
3"	grooved	2"	grooved	IFFCV0401IV2V	90	1"	3/4"	800	6
4"	grooved	2"	grooved	IFFCV0401LV2V	90	1"	3/4"	800	8
4"	grooved	3"	grooved	IFFCV0501LV3V	80	2"	3/4"	1000	10
6"	grooved	3"	grooved	IFFCV0501PV3V	80	2"	3/4"	1000	17
6"	grooved	4"	grooved	IFFCV0661PV4V	80	2"	3/4"	1320	23
DN 200	flanged	4"	grooved	IFFCV06618F4V	85	2"	3/4"	1320	49

FCV Double outlet manifold with threaded outlets for pressure tapping

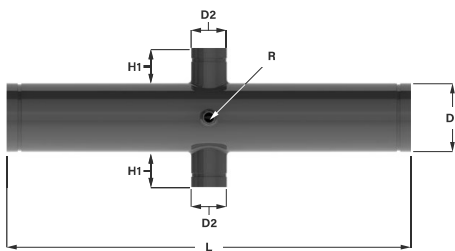

D1 (inch)		D2 (inch)		Code	H1 (mm)	R (inch)	L (mm)	Weight (kg)
6"	grooved	3"	grooved	IFFDV0501PV3V	85	3/4"	1000	18
DN 200	flanged	3"	grooved	IFFDV05018F3V	90	3/4"	1000	45
DN 200	flanged	4"	grooved	IFFDV06618F4V	85	3/4"	1320	53
DN 250	flanged	4"	grooved	IFFDV0661TF4V	85	3/4"	1320	74

SAND MEDIA

DUAL FILTERS



Advantages

- ✓ Sand filtration unit **compact and autonomous**
- ✓ **Easy to transport**
- ✓ **Completely automatable**
- ✓ **High filtering surface area**
- ✓ **Robust** and durable construction.

Principle of operation

Filtration stage

1. Dirty water enters through the inlet manifold
2. As it passes through the sand bed, the impurities are trapped
3. The filtered water exits through the outlet manifold

Backwash stage

4. One of the 3-way valves switches to the wash stage, (on command by the Control Unit)
5. The water flows in the opposite direction, in the relative chamber, removing the collected impurities (backwashing).
6. The impurities are discharged with the wash water through the discharge manifold.

Filtration stage

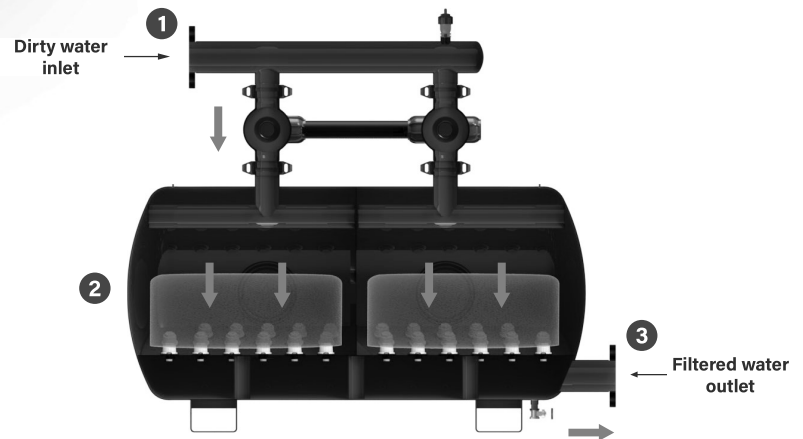

Backwash stage

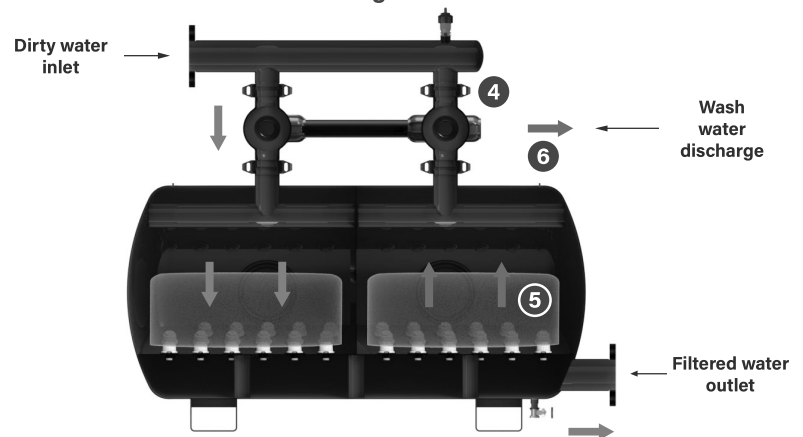

SAND MEDIA

DUAL FILTERS

PRODUCT RANGE: Dual chamber and Four chamber



ER - Dual chamber - plate drainage

- Drainage consisting of a PLATE and "mushroom" diffusers
- Models from 2" to DN125
- "Standard" lateral water outlet
- Robustness and transportability

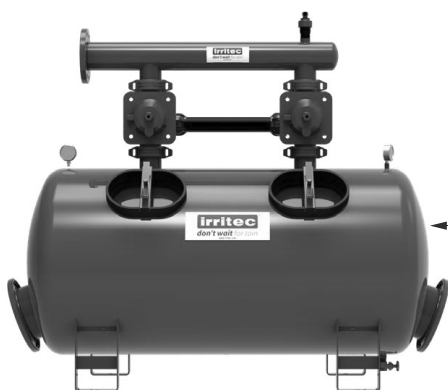

EM - Dual Chamber Maxi Flow

- Drainage consisting of "maxi flow" diffusers
- Models from 2" to DN125
- Central water outlet - allows for more compact installations
- Lightweight design - increased filter bed height



EQ3V Four chamber

- Drainage consisting of a PLATE and "mushroom" diffusers
- Special DN150 model
- Handles high flow rates (up to 160 m³/h) in a single compact body
- Robustness and transportability

ER

SAND MEDIA
DUAL FILTERS

Description

Dual chamber sand media filter with "plate" and "mushroom" diffuser drainage. It combines the functions of 2-element battery in a compact and transportable body. Ideal for treating difficult waters (high turbidity, presence of algae and other organic residues) in medium-sized systems.



Flow rate
10 - 100 m³/h



Filtering Surface
3490 - 15000 cm²



Diameters
1"1/2 - 5" (DN125)



Advantages

- ✓ **"Plate" drainage system** with very high efficiency in both the filtration and wash stages
- ✓ **Sturdy construction** with high gauge metal.
- ✓ **High surface area filtration** in a compact and transportable body
- ✓ **Large inspection and load hatches**, for easier maintenance and use

Construction materials

FILTER BODY	Structural steel
MANIFOLDS	Structural steel
COATING	Polyester powder coating (min. thickness 160 micron)
DIFFUSERS	Polypropylene
FILTERING ELEMENT	Sand (recommended grain size: 0.8 - 1.2 mm)
GASKETS	EPDM
ACCESSORIES	Polypropylene



Conditions of use

PH RANGE	4<pH<11
MAX TEMPERATURE	60 °C / 140 °F
MAX PRESSURE	8 bar at 20°C
MIN PRESSURE	2.5 bar (backwash stage)

ER

SAND MEDIA
DUAL FILTERS

Selecting the correct model

General Specifications	BODY DIAMETER	400 mm	500 mm	600 mm	750 mm	850 mm
	CONNECTIONS	1"1/2	2"	3"	4"	5"
	CONNECTION TYPE	Threaded Female		Threaded Female - Flanged		Flanged
	QUANTITY OF SAND	60 kg	120 kg	200 kg	450 kg	600 kg
	FILTERING SURFACE	3490 cm ²	4910 cm ²	6630 cm ²	11040 cm ²	15050 cm ²
	MAXIMUM FLOW RATE	11 m ³ /h	30 m ³ /h	60 m ³ /h	80 m ³ /h	110 m ³ /h
	FILTERING CAPACITY	VERY HIGH				
Backwash Data	MINIMUM FLOW RATE	7 m ³ /h	10 m ³ /h	14 m ³ /h	22 m ³ /h	30 m ³ /h
	MINIMUM PRESSURE	2.5 bar				
	MIN TIME BACKWASH	60 - 120 sec.				
	BACKWASH CRITERIA	ΔP max 0.5 bar - washing cycles according to water quality				
Applications	 AGRICULTURE	Primary filtration of "Difficult" water - medium-large systems				
	 LANDSCAPE					

Compatible automation kits
(to be ordered separately)

KTB



Ref.	Description
IFKTBS02IM	2 outlets - 12VDC latch

KFA



Ref.	Description
IFKFAU02IO	2 outlets - 24VAC

KPB





Ref.	Description
IFKPB02IM	2 outlets - 12VDC latch

KFB



Ref.	Description
IFKFB02IO	2 outlets - 12VDC latch

DUAL CHAMBER FILTER: CONTROL VALVE OPTIONS

FILTER BODY AND MANIFOLD	BALL VALVE KIT (MANUAL)	3-WAY VALVE KIT (AUTOMATABLE)
 IFERV15H		
OFER3V20H	OFKMRV0GI	IFKMV02G
OFER3V30H		
OFER3V30F		
OFER3V40H	OFKMRV0LM	IFKMV02I
OFER3V40F		
OFER3V50F		

ER

**SAND MEDIA
DUAL FILTERS**

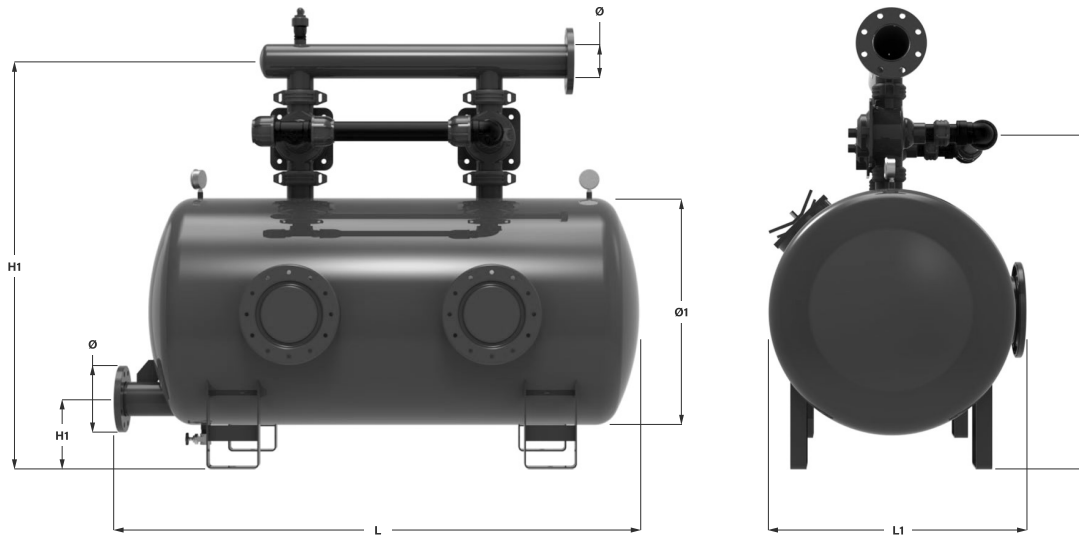

Ø body (mm)	Connections		Code	Number of Nozzles	Filtration Surface (cm ²)	Flow rate (m ³ /h)	L (mm)	H (mm)	H1 (mm)	H2 (mm)	Weight (kg)
400	1 1/2"	threaded female	IFERV15H	16	3490	5÷11	900	470	190	910	68
500	2"	threaded female	IFER3V20H	38	4910	10÷30	1160	570	190	1020	100
600	3"	threaded female	IFER3V30H	46	6630	30÷60	1350	670	245	1220	150
600		flanged	IFER3V30F			30÷60	1330				140
750	4"	threaded female	IFER3V40H	68	11040	40÷80	1730	820	245	1430	260
750		flanged	IFER3V40F				1700				270
850	5"	flanged	IFER3V50F	86	15050	70÷110	2050	920	280	1550	350

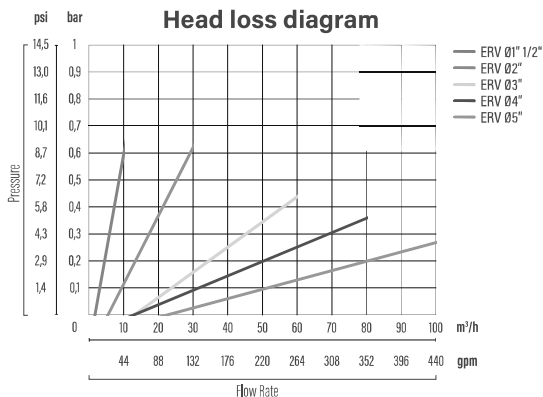
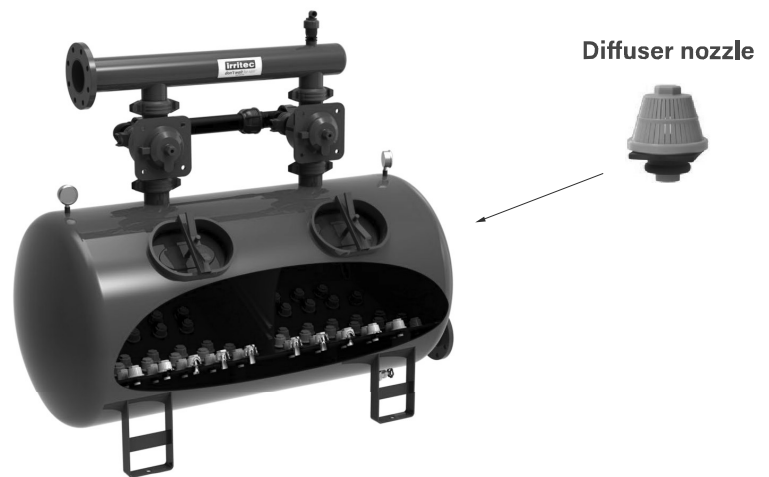

Recommended flow rate (m³/h) according to water quality

Model	Model	Flow rate Maximum	Medium Quality	Poor Quality	Very poor Quality
ER	2"	30	25	20	15
	3"	60	40	25	20
	4"	80	60	45	35
	DN125	110	90	70	45

EM

SAND MEDIA
DUAL FILTERS

Description

Dual chamber sand media filter with manifold and "maxi-flow" diffuser drainage. It combines the functions of a 2-element battery in a compact and transportable body. The unique central outlet design is ideal for compact installations and mounting on a trolley.



Flow rate
10 - 100 m³/h



Filtering Surface
4900 - 15000 cm²



Diameters
2" - 5" (DN125)

Advantages

- ✓ "Maxi-Flow" drainage system
- ✓ Greater volume of sand compared to other models on the market
- ✓ High surface area filtration in a compact and transportable body
- ✓ Large, easy to open, oval inspection and load hatches



Construction materials

FILTER BODY	Structural steel
MANIFOLDS	Structural steel
COATING	Polyester powder coating (min. thickness 160 micron)
DIFFUSERS	Polypropylene
FILTERING ELEMENT	Sand (recommended grain size: 0.8 - 1.2 mm)
GASKETS	EPDM
ACCESSORIES	Polypropylene



Conditions of use

PH RANGE	4<pH<11
MAX TEMPERATURE	60 °C / 140 °F
MAX PRESSURE	8 bar at 20°C
MIN PRESSURE	2.5 bar (backwash stage)

EM

SAND MEDIA
DUAL FILTERS

Selecting the correct model

General Specifications	BODY DIAMETER	500 mm	600 mm	750 mm	850 mm
	CONNECTIONS	2"	3"	4"	5"
	CONNECTION TYPE	Threaded Female		Flanged	
	QUANTITY OF SAND	150 kg	250 kg	500 kg	700 kg
	FILTERING SURFACE	4910 cm ²	6630 cm ²	11040 cm ²	15050 cm ²
	MAXIMUM FLOW RATE	30 m ³ /h	60 m ³ /h	80 m ³ /h	110 m ³ /h
	FILTERING CAPACITY	VERY HIGH			
Backwash Data	MINIMUM FLOW RATE	10 m ³ /h	14 m ³ /h	22 m ³ /h	30 m ³ /h
	MINIMUM PRESSURE	2.5 bar			
	MIN TIME BACKWASH	60 - 120 sec.			
	BACKWASH CRITERIA	ΔP max 0.5 bar - washing cycles according to water quality			
Applications	 AGRICULTURE	Primary filtration of "Difficult" water			
	 LANDSCAPE				

Compatible automation kits
(to be ordered separately)

KTB



Ref.	Description
IFKTBS02IM	2 outlets - 12VDC latch

KFA



Ref.	Description
IFKFAU02IO	2 outlets - 24VAC

KPB





Ref.	Description
IFKPBS02IM	2 outlets - 12VDC latch

KFB



Ref.	Description
IFKFB02IO	2 outlets - 12VDC latch

DUAL CHAMBER FILTER: CONTROL VALVE OPTIONS

FILTER BODY AND MANIFOLD	BALL VALVE KIT (MANUAL)	3-WAY VALVE KIT (AUTOMATABLE)
		
IFERV15H		
OFEM3V20H	OFKMRV0GI	IFKMV02G
OFEM3V30H		
OFEM3V40F	OFKMRV0LM	IFKMV02I
OFEM3V50F		

EM

SAND MEDIA
DUAL FILTERS

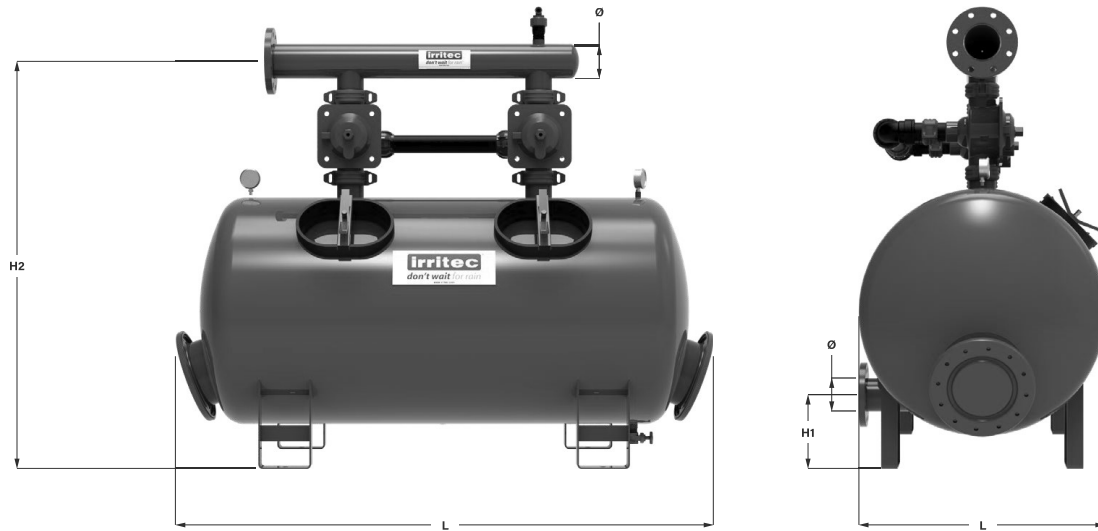

Ø body (mm)	Connections		Code	Number Nozzles	Nozzle Length (mm)	Flow rate (m³/h)	L (mm)	L1 (mm)	H1 (mm)	H2 (mm)	Weight (kg)
500	2"	threaded female	OFEM3V20H	6	383	10÷30	1250	550	190	1020	100
600	3"	threaded female	OFEM3V30H	12	420	30÷60	1450	650	245	1220	150
750	4"	flanged	OFEM3V40F	14	602	40÷80	1850	800	245	1430	270
850	5"	flanged	OFEM3V50F	18	712	70÷110	2150	900	280	1550	350

Diffuser nozzle

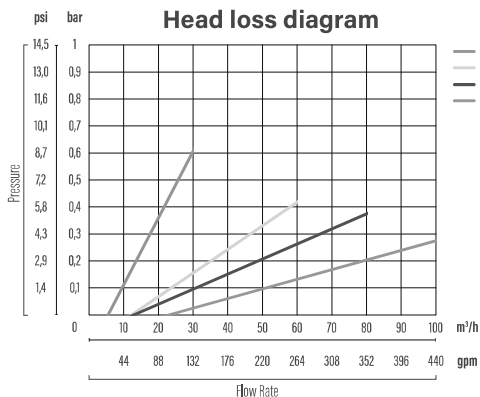

Recommended flow rate (m³/h) according to water quality

Model	Model	Flow rate Maximum	Medium Quality	Poor Quality	Very poor Quality
EM	2"	30	25	20	15
	3"	60	40	25	20
	4"	80	60	45	35
	5"	110	90	70	45

EQ3V

SAND MEDIA
 DUAL FILTERS

Description

Four chamber sand media filter with plate and "mushroom" diffuser drainage. It combines the functions of a 4-element sand media filter battery in a compact and transportable body. Complete with 3-way valves and ready to be automated.



Flow rate
 80 - 160 m³/h



Filtration Surface
 22700 cm²



Diameters
 6" (DN150)

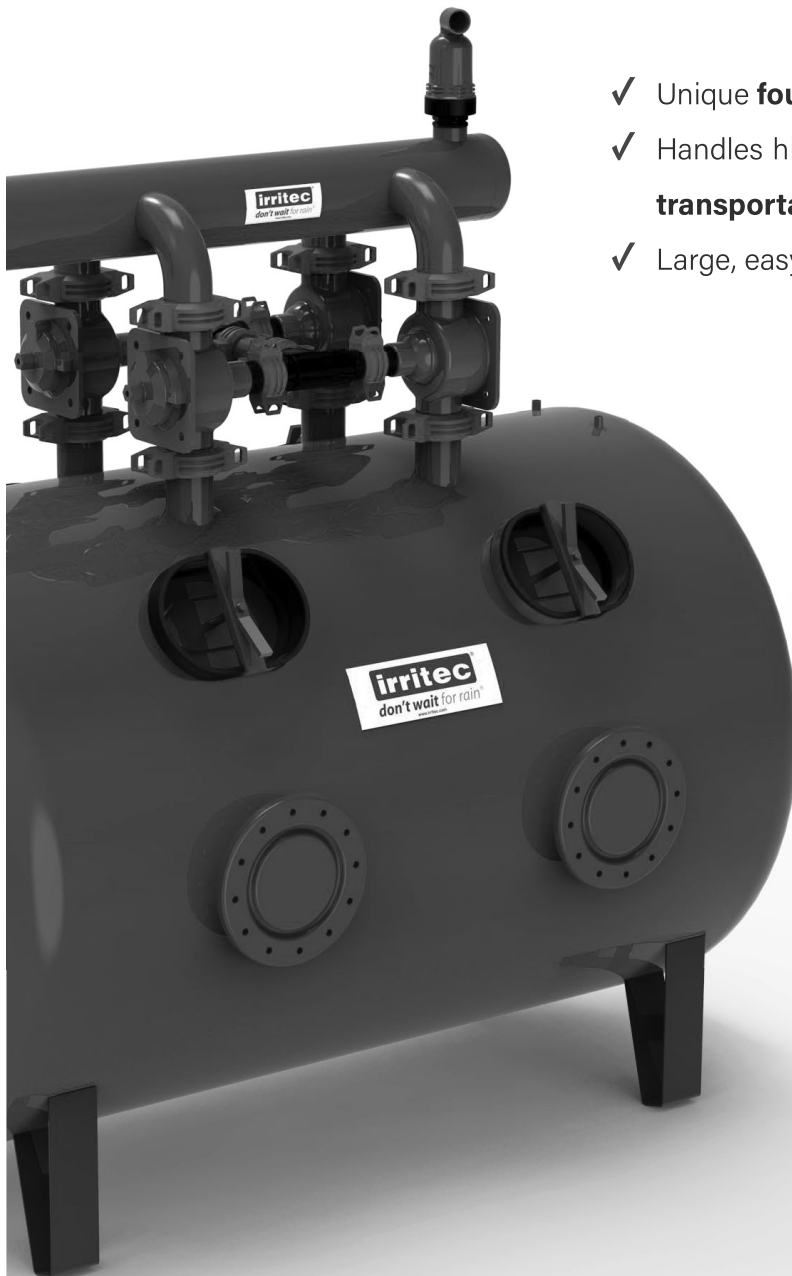

Advantages

- ✓ Unique **four chamber** DN150 model
- ✓ Handles high capacities while maintaining a **compact and transportable structure.**
- ✓ Large, easy to open, **oval inspection and load hatches**

Construction materials

FILTER BODY	Structural steel
MANIFOLDS	Structural steel
COATING	Polyester powder coating (min. thickness 160 micron)
DIFFUSERS	Polypropylene
FILTERING ELEMENT	Sand (recommended grain size: 0.8 - 1.2 mm)
GASKETS	EPDM
ACCESSORIES	Polypropylene



Conditions of use

PH RANGE	4<pH<11
MAX TEMPERATURE	60 °C / 140 °F
MAX PRESSURE	8 bar at 20°C
MIN PRESSURE	2.5 bar (backwash stage)

EQ3V

SAND MEDIA
DUAL FILTERS

Selecting the correct model

General Specifications	BODY DIAMETER	1200 mm
	CONNECTIONS	6"
	CONNECTION TYPE	Flanged
	QUANTITY OF SAND	1600 kg
	FILTERING SURFACE	22700 cm ²
	MAXIMUM FLOW RATE	160 m ³ /h
FILTERING CAPACITY	VERY HIGH	
Backwash Data	MINIMUM FLOW RATE	35 m ³ /h
	MINIMUM PRESSURE	2.5 bar
	MIN TIME BACKWASH	60 - 120 sec.
	BACKWASH CRITERIA	ΔP max 0.5 bar - washing cycles according to water quality
Applications	 AGRICULTURE	Primary filtration of "difficult" water - medium-large systems
	 LANDSCAPE	

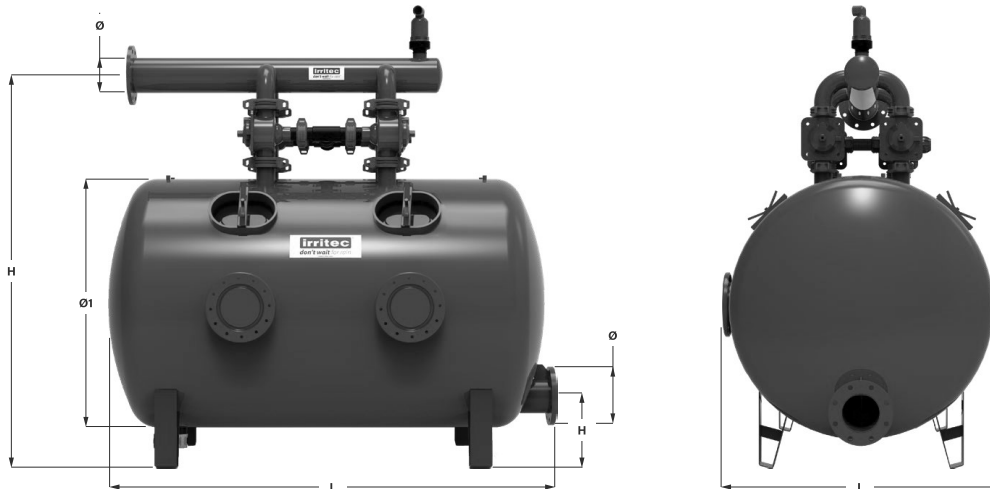

Ø body (mm)	Connections		Code	Number of Nozzles	Flow rate (m ³ /h)	L (mm)	L1 (mm)	H1 (mm)	H2 (mm)	Weight (kg)
1200	6"	flanged	IFEQ3V60F	192	80-160	2200	1350	300	1850	860

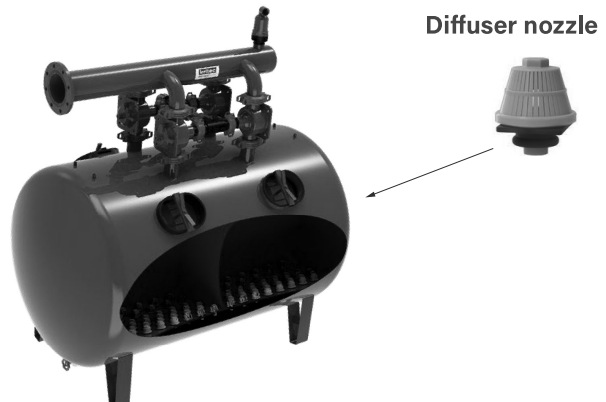
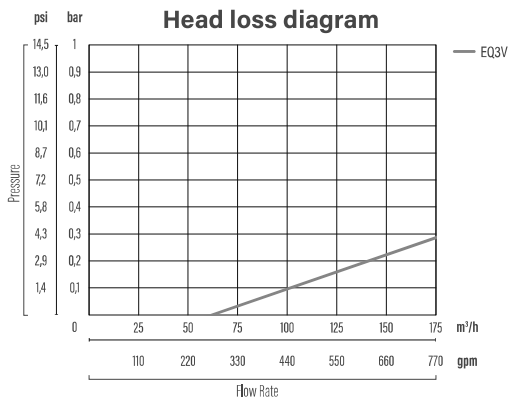

METAL SCREEN FILTERS



Flow rate
Up to 300 m³/h

75
(200 micron)



Filtering Surface
960 - 6028 cm²

120
(130 micron)



Diameters
2" - 8"

155
(100 micron)

Advantages

- ✓ **Sturdy construction** with high thickness steel.
- ✓ **Wide range of models** Traditional and Semi-automatic
- ✓ **"Handwheel" opening** on all models to facilitate the opening and closing of the filter



Construction materials







FILTER BODY	Structural steel
MANIFOLDS	Structural steel
COATING	Polyester powder coating (min. thickness 160 micron)
FILTERING ELEMENT	Stainless steel screen (standard grade 120 mesh) on perforated PVC support
GASKETS	EPDM

Conditions of use

PH RANGE	4<pH<11
MAX TEMPERATURE	60 °C / 140 °F
MAX PRESSURE	8 bar at 20°C

METAL SCREEN FILTERS

Selecting the correct model

	EDV90	EDV	ESV	EPV90	EPV	
MODEL						
FILTERING ELEMENT	Disks		Polyester Screen + Stainless Steel Cylinder	Stainless Steel Screen + PVC Structure		
General Specifications	DIAMETERS	2" - 4"		2" - 5"	2" - 6"	2" - 8"
	CONNECTIONS	Threaded Female	Threaded Female - Flanged (according to size)			
	FILTRATION DEGREES	75 - 120 - 155 mesh 200 - 130 - 100 micron				
	RANGE OF FLOW RATES	15 - 80 m³/h		15 - 110 m³/h	15 - 150 m³/h	15 - 300 m³/h
	FILTERING SURFACE	1196 - 1868 cm²		1260 - 4769 cm²	1055 - 4929 cm²	1055 - 6028 cm²
Applications	 AGRICULTURE	Secondary filtration (back-up filter)				
	 LANDSCAPE	Primary filtration of good quality well water				
		Primary Filtration of good quality water				



EPV

**METAL SCREEN
FILTERS**

Description

Manual screen filter for in-line installation. Filtering element with stainless steel screen bonded to a perforated PVC cylinder. Available in a wide range of sizes (up to 8"). Sturdy metal construction with handwheel making it easy to open.

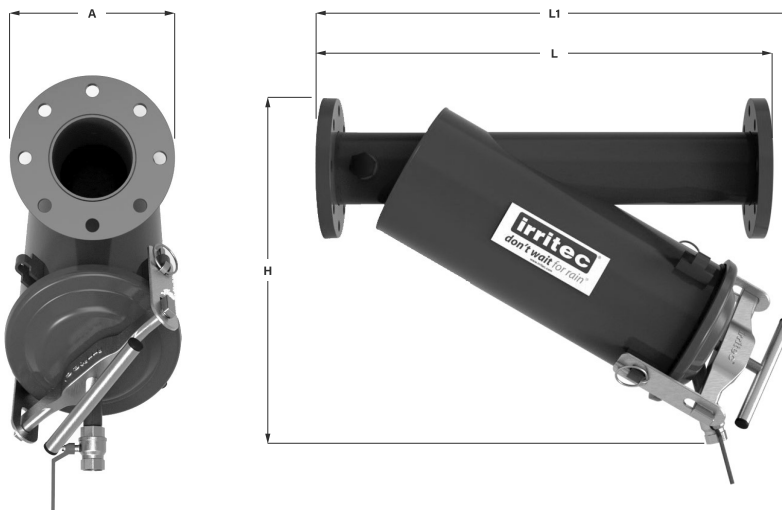

Internal	Connections	Code	PN	Flow rate (m ³ /h)	Filtering Surface (cm ²)	Ø body (inch)	L (mm)	L1 (mm)	A (mm)	H (mm)	Weight (kg)
2"	threaded female	IFEPV20Hyy	8	15÷30	1055	6"	440	530	300	400	11
3"	threaded female	IFEPV30Hyy		25÷40	1625		660	710		450	17
	flanged	IFEPV30Fyy				610	660	500		24	
4"	threaded female	IFEPV40Hyy		40÷80	2318	8"	770	860		580	25
	flanged	IFEPV40Fyy					710	830		600	34
5"	flanged	IFEPV50Fyy		80÷110	3014	720	940	650		41	
6"	flanged	IFEPV60Fyy		110÷150	4929	1000	1100	700		60	
8"	flanged	IFEPV80Fyy		150÷300	6028	8"	800	800		350	1350

Filtering cartridge



Filtration degree (mesh)

yy: mesh (replace with:)

Ref.	Mesh	Micron	Colour
08	75	200	
12	120	130	
15	155	100	

Typical installation

	X min (mm)	Y min (mm)
2"	900	400
3"	1000	450
DN 80	1050	450
4"	1650	650
DN 100	1650	650
DN 125	2000	800
DN 150	2200	1000

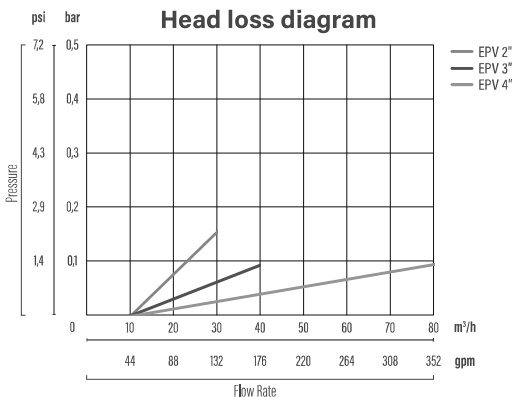
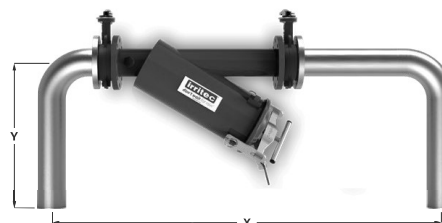

EPV90° METAL SCREEN FILTERS

Description

Manual screen filter for 90° installation. Filtering element with stainless steel screen bonded to a perforated PVC cylinder. The 90° installation allows the product to be installed with a reduced footprint. Sturdy metal construction with handwheel making it easy to open.

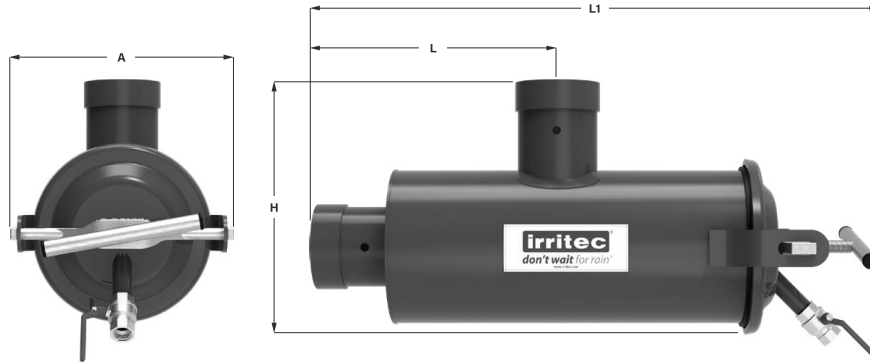

Internal	Connections	Code	PN	Flow rate (m³/h)	Filtering Surface (cm²)	Ø body (inch)	L (mm)	L1 (mm)	A (mm)	H (mm)	Weight (kg)
2"	threaded female	IFEPV9020Hyy	8	15÷30	1055	6"	510	230	300	270	12
3"	threaded female	IFEPV9030Hyy		25÷40	1625	6"	660	310		300	13
4"	threaded female	IFEPV9040Hyy		40÷80	2318	8"	790	360		360	24
6"	flanged	IFEPV9060Fyy		110÷150	4929	10"	1130	530		440	55

Filtering cartridge



Filtration degree (mesh)
yy: mesh (replace with:)

Ref.	Mesh	Micron	Colour
08	75	200	
12	120	130	
15	155	100	

Typical installation

	X min (mm)
2"	650
3"	950
4"	1200
DN 150	1800

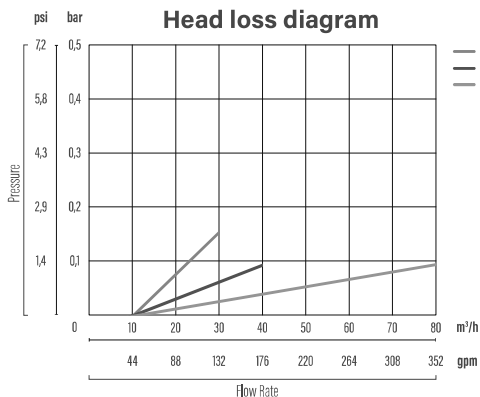
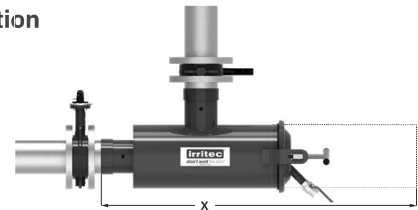

ESV **METAL SCREEN**
FILTERS

Description

Manual screen filter for in-line installation. Polyester screen filtering element (replaceable) applied to a stainless steel support cylinder. Sturdy metal construction with handwheel making it easy to open.

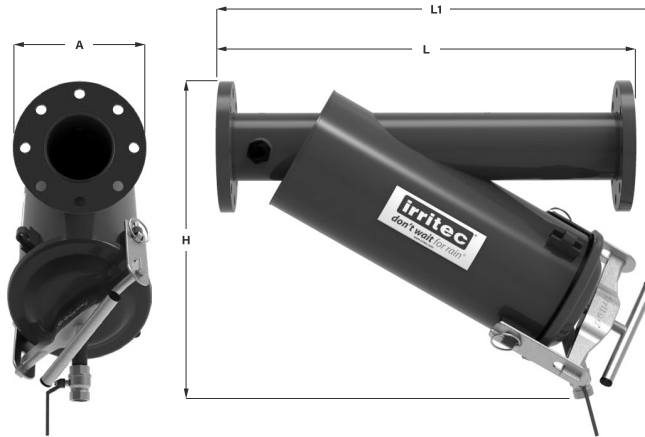

Internal	Connections	Code	PN	Flow rate (m ³ /h)	Filtering Surface (cm ²)	Ø body (inch)	L (mm)	L1 (mm)	A (mm)	H (mm)	Weight (kg)
2"	threaded female	IFESV20Hyy	8	15÷30	1055	6"	440	530	300	400	13
3"	threaded female	IFESV30Hyy		25÷40	1625		660	710		450	17
	flanged	IFESV30Fyy		610	660		500	24			
4"	threaded female	IFESV40Hyy		40÷80	2318	8"	770	860		580	19
	flanged	IFESV40Fyy		710	830		600	28			
5"	flanged	IFESV50Fyy		80÷110	3014	720	920	650		38	

Filtering cartridge



Filtration degree (mesh)

yy: mesh (replace with:)

Ref.	Mesh	Micron	Colour
08	75	200	
12	120	130	
15	155	100	

Typical installation

	X min (mm)	Y min (mm)
2"	900	400
3"	1000	450
DN 80	1050	450
4"	1650	650
DN 100	1650	650
DN 125	2000	800

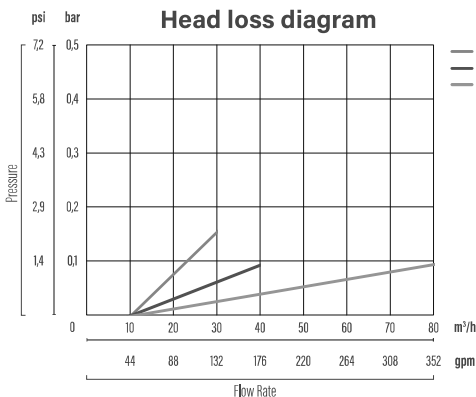
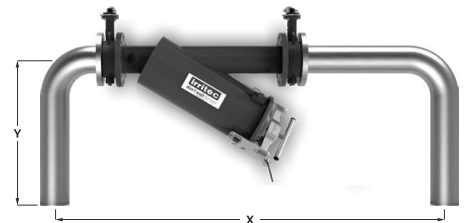

EDV

METAL SCREEN FILTERS

Description

Manual Disk filter for in-line installation. Highly robust polypropylene Disk filtering element with efficient filtration. Sturdy metal construction with handwheel making it easy to open.

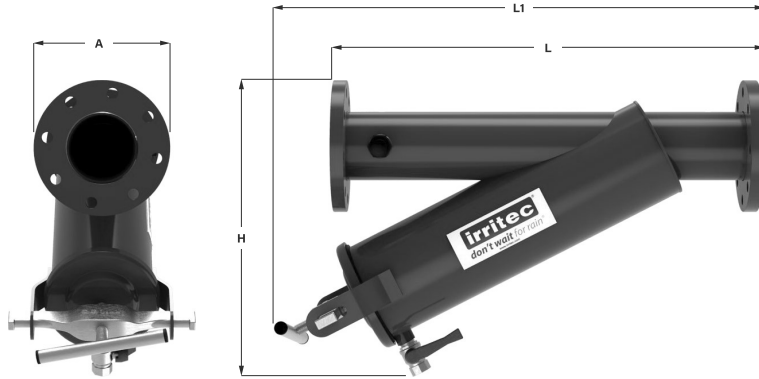

Internal	Connections	Code	PN	Flow rate (m³/h)	Filtering Surface (cm²)	Ø body (inch)	L (mm)	L1 (mm)	A (mm)	H (mm)	Weight (kg)
2"	threaded female	IFEDV20Hyy	8	15÷30	960	6"	440	530	300	400	14
3"	threaded female	IFEDV30Hyy					660	710		450	20
	flanged	IFEDV30Fyy		610	660		500	22			
4"	threaded female	IFEDV40Hyy		40÷80	1980		8"	770		860	580
	flanged	IFEDV40Fyy	710			830		600	32		

Filtering cartridge



Filtration degree (mesh)

yy: mesh (replace with:)

Ref.	Mesh	Micron	Colour
08	75	200	
12	120	130	
15	155	100	

Typical installation

	X min (mm)	Y min (mm)
2"	900	400
3"	1000	450
DN 80	1050	450
4"	1650	650
DN 100	1650	650

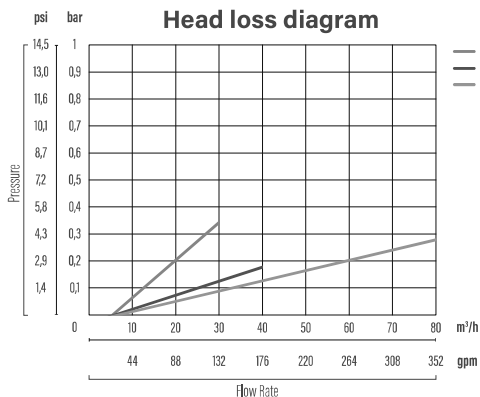
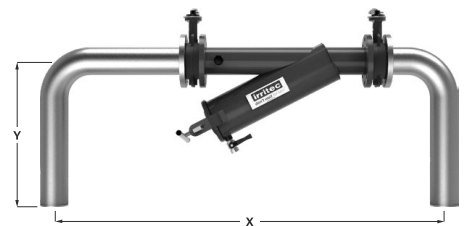

EDV90° METAL SCREEN FILTERS

Description

Manual Disk filter for 90° installation. Highly robust polypropylene Disk filtering element with efficient filtration. The 90° installation allows the product to be installed with a reduced footprint.



Internal	Connections	Code	PN	Flow rate (m³/h)	Filtering Surface (cm²)	Ø body (inch)	L (mm)	L1 (mm)	A (mm)	H (mm)	Weight (kg)
2"	threaded female	IFEDV9020Hyy	8	15÷30	960	6"	550	250	300	330	14
3"	threaded female	IFEDV9030Hyy		25÷40	1470		680	320		360	20
4"	threaded female	IFEDV9040Hyy		40÷80	1980		810	390		330	25

Filtering cartridge



Filtration degree (mesh)

yy: mesh (replace with:)

Ref.	Mesh	Micron	Colour
08	75	200	
12	120	130	
15	155	100	

Typical installation

	X min (mm)
2"	750
3"	1000
4"	1250

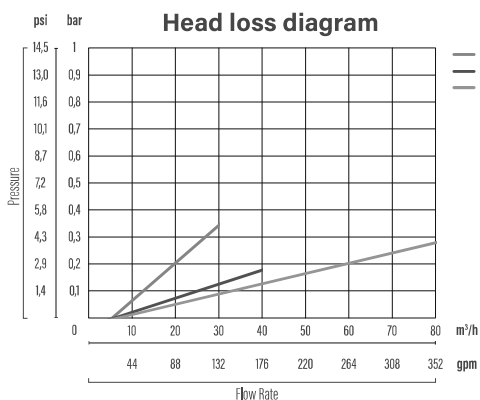
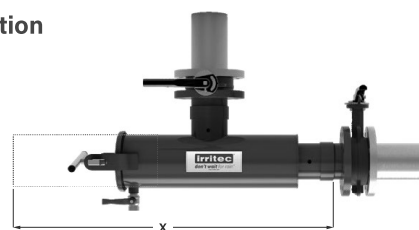

METAL SCREEN

SEMI AUTOMATIC FILTERS



Flow rate
240 m³/h



Filtering Surface
1055 - 6028 cm²



Diameters
2" - 8"

75
(200 micron)

120
(130 micron)

155
(100 micron)

Advantages

- ✓ Semi-automatic cleaning system
- ✓ Reduces maintenance time
- ✓ Cyclonic and Brush models



Construction materials

FILTER BODY	Structural steel
MANIFOLDS	Structural steel
COATING	Polyester powder coating (min. thickness 160 micron)
FILTERING ELEMENT	Stainless steel screen - PVC support structure
GASKETS	EPDM





Conditions of use

PH RANGE	4<pH<11
MAX TEMPERATURE	60 °C / 140 °F
MAX PRESSURE	8 bar at 20°C







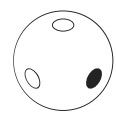
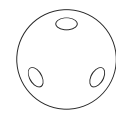

METAL SCREEN

SEMI AUTOMATIC FILTERS

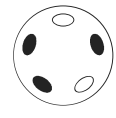
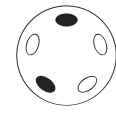
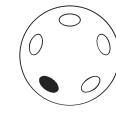
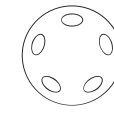
Selecting the correct model

	MODEL		
	FILTERING ELEMENT	Stainless Steel Screen + PVC Structure	
	CLEANING MECHANISM	cyclonic	cyclonic with brush
General Specifications	DIAMETERS	2" - 8"	2" - 6"
	CONNECTIONS	Threaded Female - Flanged	
	FILTRATION DEGREES	80 - 120 - 155 mesh 200 - 130 - 100 micron	
	RANGE OF FLOW RATES	11 - 240 m ³ /h	11 - 150 m ³ /h
	FILTERING SURFACE	1055 - 6028 cm ²	1055 - 4929 cm ²
Applications	 AGRICULTURE	Secondary filtration (back-up filter)	
		Primary filtration of medium-quality water	
	 LANDSCAPE	Main filtration of medium-quality water	

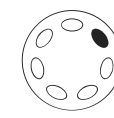
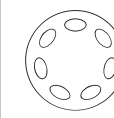
Recommended flow rate

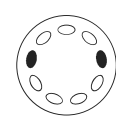
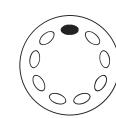
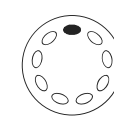
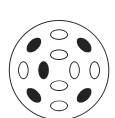
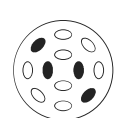
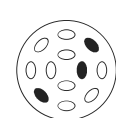
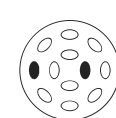
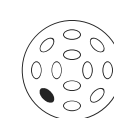
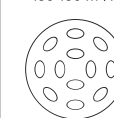
SIZE	Configuration					
2"	11-11 m ³ /h	13-20 m ³ /h	20-31 m ³ /h			
						
3"	12-14 m ³ /h	14-17 m ³ /h	17-25 m ³ /h	25-33 m ³ /h	33-40 m ³ /h	
						
4"	20-24 m ³ /h	24-28 m ³ /h	28-36 m ³ /h	36-44 m ³ /h	44-53 m ³ /h	53-70 m ³ /h
						
5"	44-48 m ³ /h	48-55 m ³ /h	55-72 m ³ /h	72-91 m ³ /h	91-110 m ³ /h	
						
6"	74-80 m ³ /h	80-89 m ³ /h	89-105 m ³ /h	105-122 m ³ /h	122-136 m ³ /h	136-150 m ³ /h
						

Operational note

For maximum effectiveness of the turbulent flow cleaning mechanism, a DP Sensor of approximately 0.5 bar must be maintained between the inlet and outlet. Fit the number of plugs required (supplied) according to the water flow rate.

EAV

METAL SCREEN SEMI AUTOMATIC FILTERS

Description

Semi-automatic screen filter for in-line installation with "turbulence" cleaning mechanism. Filtering element with stainless steel screen bonded to a perforated PVC cylinder. Available in a wide range of sizes (up to 8"). Sturdy metal construction.

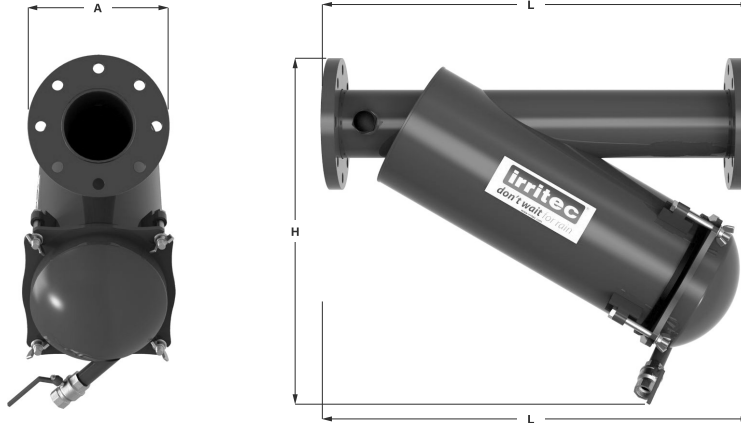

Internal	Connections	Code	PN	Flow rate (m³/h)	Filtering Surface (cm²)	Ø body (inch)	L (mm)	L1 (mm)	A (mm)	H (mm)	Weight (kg)
2"	threaded female	IFEAV20Hyy	8	11÷31	1055	6"	440	450	300	400	16
3"	threaded female	IFEAV30Hyy					660	660		450	20
	flanged	IFEAV30Fyy		610	610		500	27			
4"	threaded female	IFEAV40Hyy		20÷70	2318	8"	770	770		580	31
	flanged	IFEAV40Fyy					710	710		600	40
5"	flanged	IFEAV50Fyy		40÷110	3014		720	840		680	45
6"	flanged	IFEAV60Fyy		70÷150	4929	10"	1000	1100		730	63
8"	flanged	IFEAV80Fyy		100÷240	6028	8"	800	800		350	1350

Filtering cartridge Filtration degree (mesh)



yy: mesh (replace with:)

Ref.	Mesh	Micron	Colour
08	75	200	
12	120	130	
15	155	100	

Typical installation

	X min (mm)	Y min (mm)
2"	900	400
3"	1000	450
DN 80	1050	450
4"	1650	650
DN 100	1650	650
DN 125	2000	800
DN 150	2200	1000

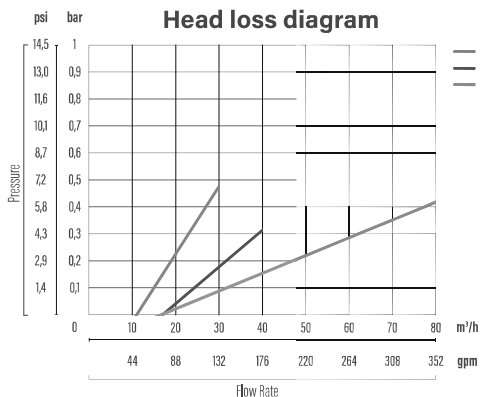
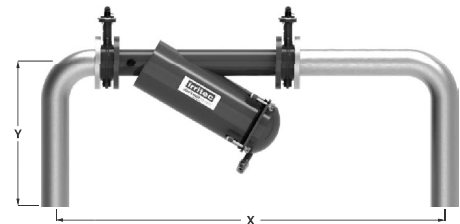

EBV METAL SCREEN
SEMI AUTOMATIC FILTERS

Description

Semi-automatic screen filter for in-line installation with "turbulence" cleaning mechanism. The filter is also equipped with an internal brush that can be operated via the external handle. Filtering element with stainless steel screen bonded to a perforated PVC cylinder. Sturdy metal construction.

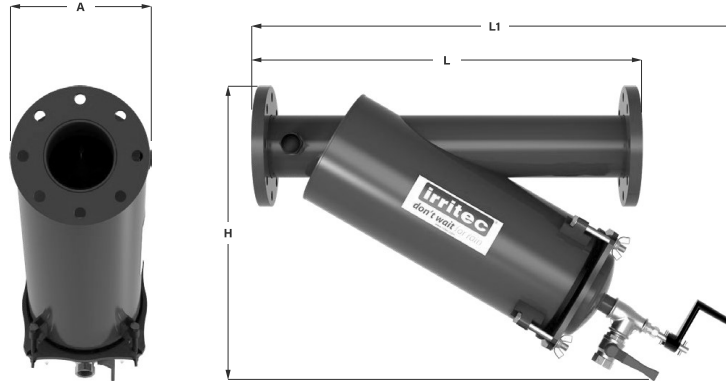

Internal	Connections	Code	PN	Flow rate (m ³ /h)	Filtering Surface (cm ²)	Ø body (inch)	L (mm)	L1 (mm)	A (mm)	H (mm)	Weight (kg)
2"	threaded female	IFEBV20Hyy	8	11÷31	1055	6"	440	700	300	500	13
3"	threaded female	IFEBV30Hyy		12÷40	1625		660	900		550	16
	flanged	IFEBV30Fyy					610	900		550	23
4"	threaded female	IFEBV40Hyy		20÷70	2318	770	1000	650		24	
	flanged	IFEBV40Fyy				710	1000	650		34	
5"	flanged	IFEBV50Fyy		40÷110	3014	720	1100	750		43	
6"	flanged	IFEBV60Fyy	70÷150	4929	1000	1250	900	68			

Filtering cartridge



Filtration degree (mesh)
yy: mesh (replace with:)

Ref.	Mesh	Micron	Colour
08	75	200	
12	120	130	
15	155	100	

Typical installation

	X min (mm)	Y min (mm)
2"	900	450
3"	1000	500
DN 80	1050	500
4"	1650	700
DN 100	1650	700
DN 125	2000	850
DN 150	2200	1050

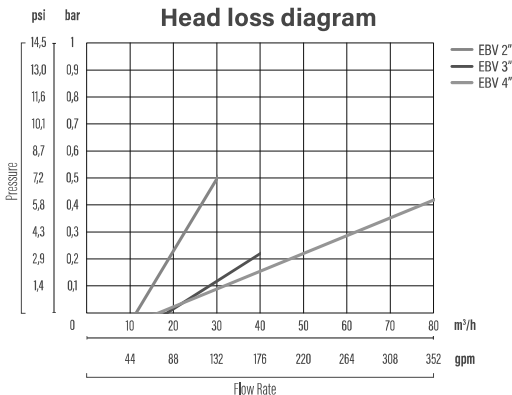
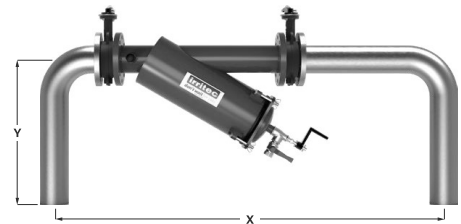

HYDROCICLONE



Flow rate
3 - 120 m³/h



Diameters
3/4" - 5"

Advantages

- ✓ **Efficient pre-filtration system** to remove sand
- ✓ **Collection tank** included (on 2" to 5" models).
- ✓ **Wide range of models** for every application
- ✓ **Also available as a complete battery** (Model ETS)

Principle of operation

The particular conical shape, together with the tangential water inlet, give the flow a "vortex" motion. The centrifugal force generated separates the suspended sand. The sand then accumulates in the lower collection tank.

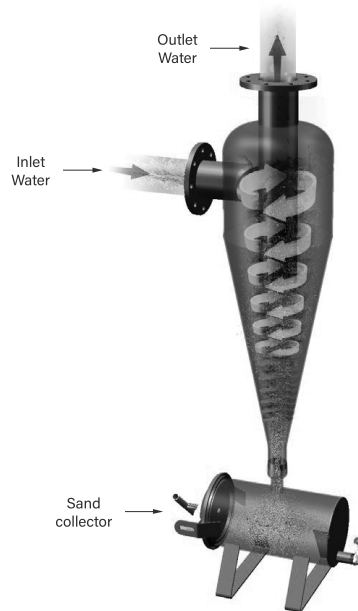

Construction materials

FILTER BODY	Structural steel
MANIFOLDS	Structural steel
COATING	Polyester powder coating (min. thickness 160 micron)
GASKETS	EPDM

Conditions of use

PH RANGE	4 < pH < 11
MAX TEMPERATURE	60 °C / 140 °F
MAX PRESSURE	8 bar at 20°C



EIV HYDROCICLONE

Description

Hydrocyclone sand separator. Ideal for the PRE-Treatment of well water with high levels of suspended sand. Wide range of sizes available (3/4" to 5") for all agricultural and residential applications. Sturdy construction with high gauge metal.



Internal	Connections	Code	Type	Ø body (mm)	PN	Flow rate (m ³ /h)	L (mm)	H (mm)	H1 (mm)	A (mm)	Weight (kg)				
3/4"	threaded female	IFEIV03H	Type A	89	8	3÷5	285	580	660	55	7				
1"	threaded female	IFEIV10H				5÷12		780			10				
1 1/2"	threaded female	IFEIV15H				10÷16		860			10				
2"	threaded female	IFEIV20H219	Type B	219	8	15÷25	520	1125	960	70	25				
	grooved	IFEIV20W219						1100			24				
3"	threaded female	IFEIV30H219				30÷50		1130			65	29			
	grooved	IFEIV30W219						1100		28					
3" L	threaded female	IFEIV30H320				40÷60		320		8	660	1485	1230	115	38
	flanged	IFEIV30F320										1460			45
4"	threaded female	IFEIV40H320	50÷80	400	8	660	1490		100		130	45			
	grooved	IFEIV40W320					1450					44			
	flanged	IFEIV40F320					1460					54			
5"	flanged	IFEIV50F400	80÷120	1780	1475	130	83								

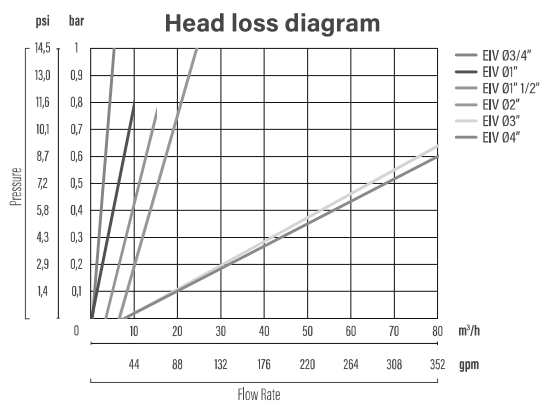

ETS BATTERIES HYDROCICLONE

Description

Complete battery for filtering well water. Consisting of hydrocyclone sand separator + screen filter + fertigation bypass kit. Ideal for filtering well water with high levels of suspended sand. Sturdy high gauge metal construction, compact and easily transportable assembly.

Construction materials

FILTER BODY	Structural steel
MANIFOLDS	Structural steel
COATING	Polyester powder coating (min. thickness 160 micron)
GASKETS	EPDM

Conditions of use

PH RANGE	4<pH<11
MAX TEMPERATURE	60 °C / 140 °F
MAX PRESSURE	8 bar at 20°C

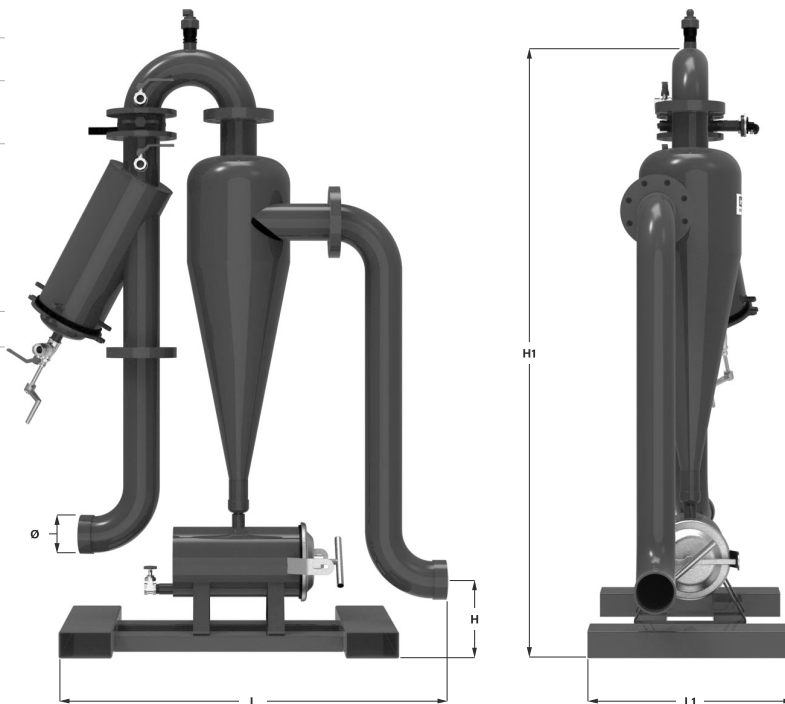

Connections		Code	Screen filter	PN	Flow rate (cm ²)	L (mm)	L1 (mm)	H (mm)	H1 (mm)	Min flow rate (m ² /h)	Max flow rate (m ² /h)
2"	threaded female	IFETS120H12	ESV	8	15÷30	1100	500	180	1400	15	30
3"	threaded female	IFETS130H12	ESV		25÷40	1300	550	190	1450	25	40
4"	threaded female	IFETS140H12	ESV		40÷80	1400	600	180	1770	40	80
DN 125	flanged	IFETS150F12	ESV		80÷110	1350	730	230	2070	80	110
2"	threaded female	IFETS220H12	EDV		15÷30	1100	500	180	1400	15	30
3"	threaded female	IFETS230H12	EDV		25÷40	1300	550	190	1450	25	40
4"	threaded female	IFETS240H12	EDV		40÷80	1400	600	180	1770	40	80
2"	threaded female	IFETS420H12	EBV		11÷31	1100	500	180	1400	11	31
3"	threaded female	IFETS430H12	EBV		12÷40	1300	550	190	1450	12	40
4"	threaded female	IFETS440H12	EBV		20÷70	1400	600	180	1770	20	70
DN 125	flanged	IFETS450F12	EBV		40÷110	1350	730	230	2070	40	110
2"	threaded female	IFETS520H12	EAV		11÷31	1100	500	180	1400	11	31
3"	threaded female	IFETS530H12	EAV		12÷40	1300	550	190	1450	12	40
4"	threaded female	IFETS540H12	EAV		20÷70	1400	600	180	1770	20	70
DN 125	flanged	IFETS550F12	EAV		40÷110	1350	730	230	2070	40	110

Filtration | Automatic screen filters

The result of the collaboration between Irritec and Triangle water-equip, this range of self-cleaning screen filters represents an uncompromising choice in the world of screen filtration. Characterised by the AISI 304 stainless steel construction and use of high quality components, they are guaranteed to be long-lasting and effective

in filtering all types of water used in agriculture, public parks, golf courses and industry.

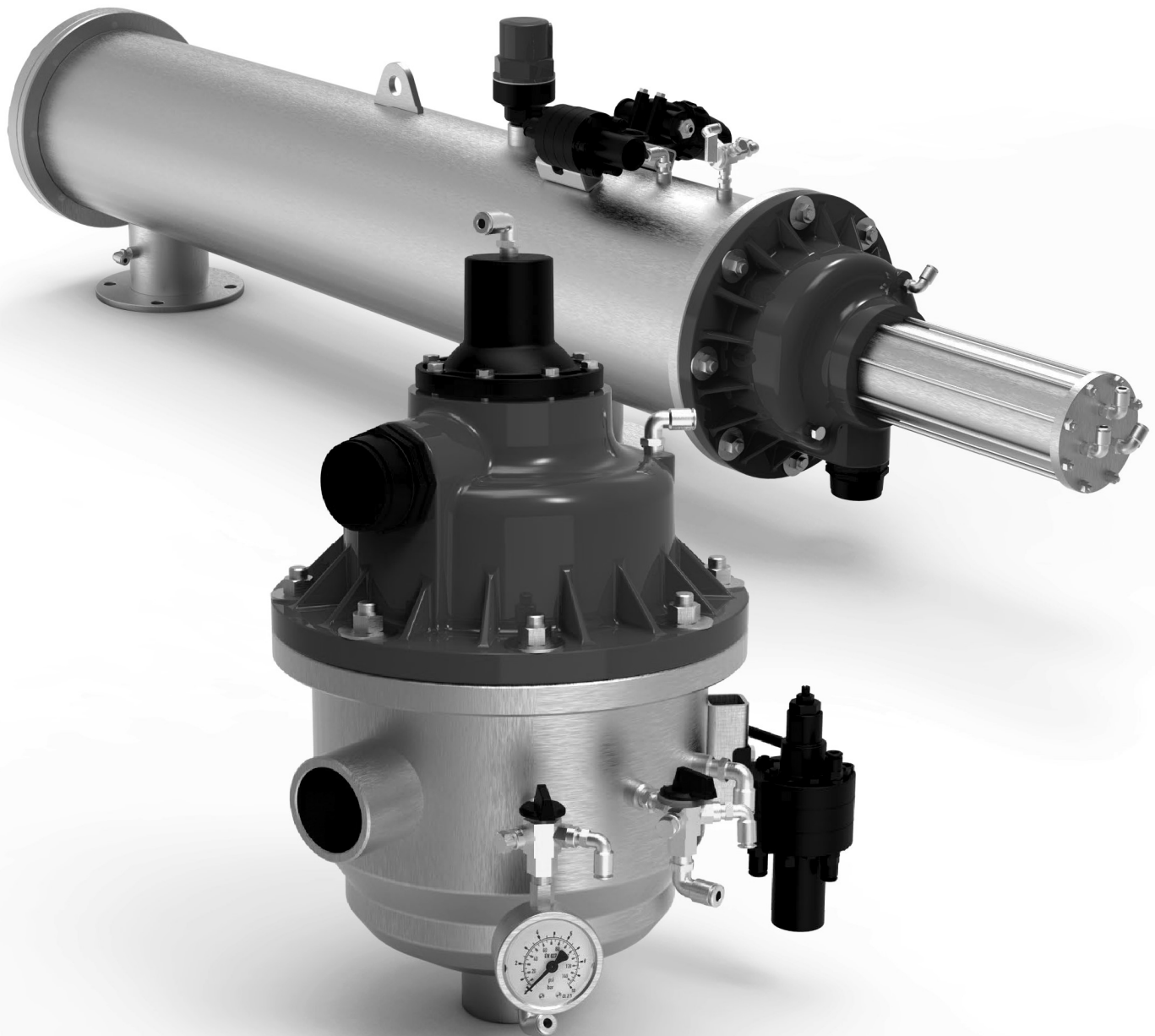

Advantages

- ✓ **Complete range** of automatic screen filters.
- ✓ **Hydraulically operated** cleaning unit (no electric power supply required)
- ✓ **Extremely robust** stainless steel construction
- ✓ **Very quick cleaning cycles** to optimise the use of water.
- ✓ **Small footprint** and easy to transport

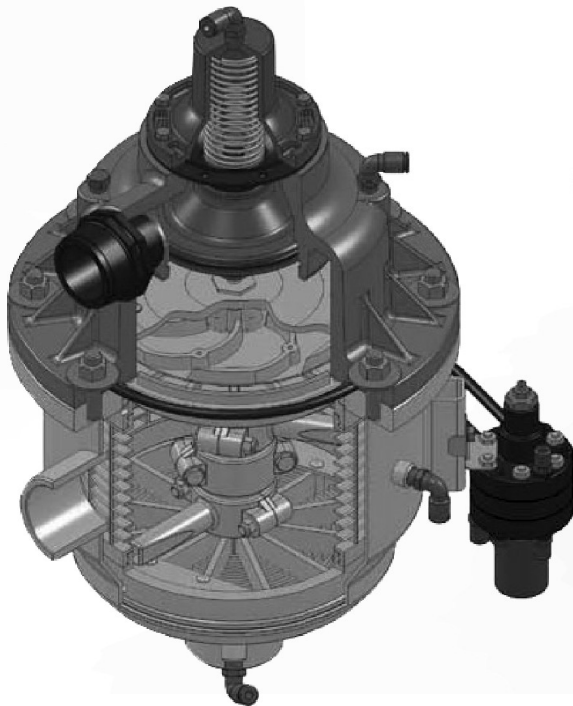

Filtration

1. Water enters the filter through a pre-filter that prevents stones and coarse particles from entering.
2. Water flows from the inside to the outside through the screen filter and the dirt is trapped inside.
3. The hydraulic mechanism is in standby mode (stopped)



Backwash

When the hydraulic control unit detects a pressure difference of more than 0.5 bar, a backwash cycle is activated.

1. The cleaning manifold and the nozzles begin to rotate and traverse longitudinally.
2. The filter begins to discharge the wash water, creating a vacuum in the cleaning manifold.
3. The suction created at the nozzles effectively removes dirt and regenerates the initial state of the filter.

FILTAWORX



"Vertical" models

- Compact and small footprint models
- Available in sizes from 2" to 4" (DN100)
- Standard filtration: 120 mesh (130 micron), available with 155 mesh (100 micron) filtration and other filtration degrees on request
- Hydraulic backwash unit - No electric power supply required.

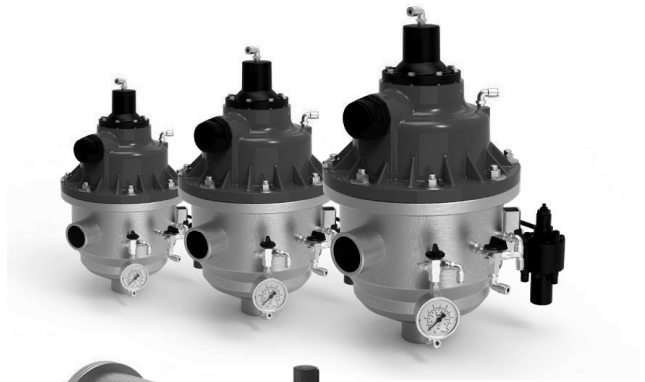





"Horizontal" models

- High filtering surface area
- Available in sizes from 4" to 14" (DN350)
- Standard filtration: 120 mesh (130 micron), available with 155 mesh (100 micron) filtration and other filtration degrees on request
- Hydraulic backwash unit - No electric power supply required.



Selecting the correct model

D. IN/OUT		2"	3"		4" (DN100)			6" (DN150)		DN200	DN250	DN300	DN350	
		FW050	FW080	FW080EX	FW100	FW100EX	FW100EXL	FW150	FW150EX	FW200	FW250	FW250EX	FW300	FW350
MODEL														
General Specifications	CONNECTIONS	Threaded F					Flanged							
	FILTRATION DEGREE	120 - 155 mesh 130 - 100 micron												
	Q.MAX (m³/h)	25	50	80	100	180	320	400	600	900				
	FILTERING SURFACE (cm²)	1220		1980	5600	8115	5600	8115		10145		12170		
Backwash Data	Q. MIN WASH	15 m³/h					35 m³/h							
	P. MIN WASH	2.5 bar												
	WASH CYCLE DURATION	7 - 10 sec					15 - 20 sec							
Applications	 AGRICULTURE	Primary filtration on medium to large sized systems (water quality from POOR to GOOD)												
		Secondary filtration on "problematic" water (water with high lime and clay content)												
	 LANDSCAPE	Main filtration on large sized systems (parks, public green spaces, golf courses etc.)												

FW050 - 100

FILTAWORX
Self Cleaning Filters



FW050 – FW100

50 - 100mm (2"-4")



Flow rate
25 - 80 m³/h



Filtering Surface
1220 - 1980 cm²



Diameters
2" - 4" (DN125)

Advantages

- ✓ Simple and compact installation.
- ✓ Highly reliable and robust.
- ✓ Rapid and efficient wash cycles.

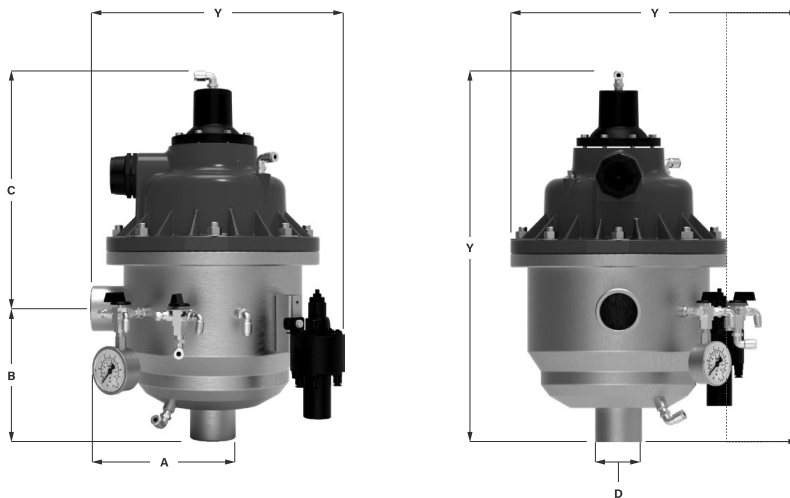

Model	Nominal Size D		IN/OUT connections	Nominal flow rate 2 m of pressure loss		Filtering surface cm ²	Size (mm)					Weight (kg)	
	inches	mm		litres/sec	m ³ /h		A	B	C	X	Y	Empty	Full
FW 050	2	50	2" BSP	7	25	1220	184	198	204	720	560	22	42
FW 050 - F	2	50	DN 50	7	25	1220	210	210	204	720	575	23	43
FW 080	3	80	3" BSP	14	50	1220	194	213	204	720	575	22	42
FW 080 - F	3	80	DN 80	14	50	1220	210	210	204	720	575	25	45
FW 080 - EX	3	80	DN 80	14	50	1980	210	315	215	900	680	29	55
FW 100	4	100	DN 100	22	80	1980	235	315	215	900	680	30	57

FW050 - 100



Conditions of use

MINIMUM OPERATING PRESSURE	200 kPa (2bar) always
MAXIMUM OPERATING PRESSURE	Standard 1000 kPa (10bar), higher pressure available on request
MAXIMUM OPERATING TEMPERATURE	65°C

Construction materials

FILTER BODY	AISI 304 stainless steel (316 and other grades available on request)
COVER	GRN (glass-reinforced nylon), stainless steel, EPDM and natural rubber
CLEANING MECHANISM	Stainless steel, brass, GRN
MAIN FILTER	316 stainless steel screen, GRN
PRE-FILTER	GRN
GASKETS	NBR
CONTROL UNIT	Acetal, stainless steel, brass, PVC
CONTROL UNIT PIPES	Polyethylene



Head loss diagram

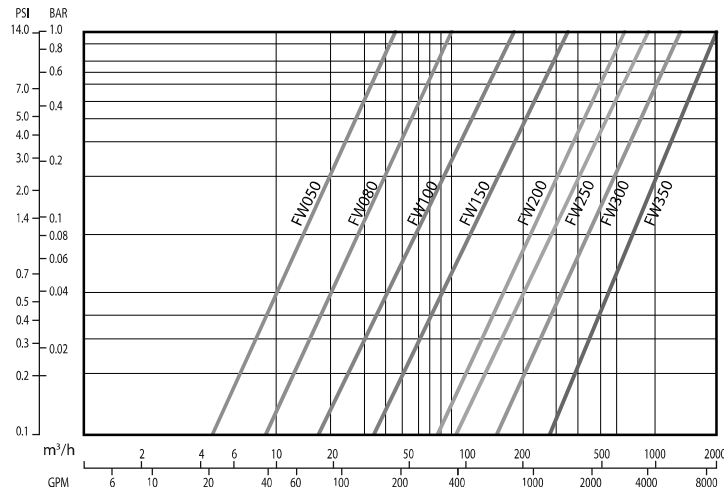

FW100EX - 350

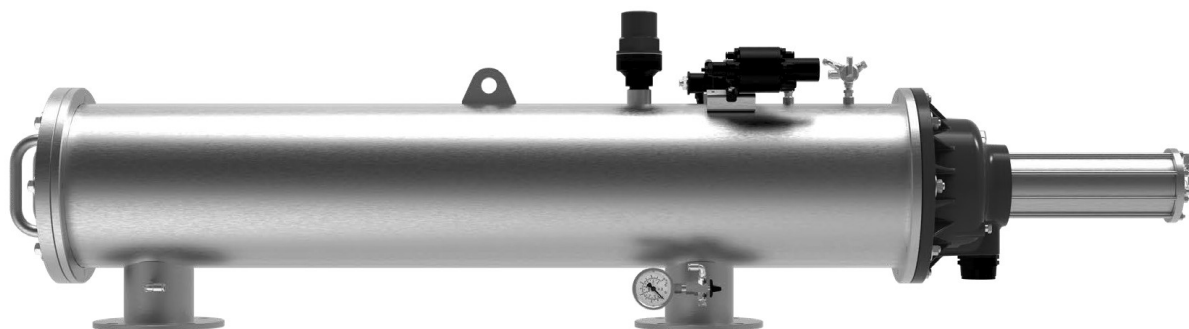

FW100EX – FW350

100 - 350mm (4"-14")



Flow rate
100 - 900 m³/h



Filtering Surface
5600 - 12170 cm²



Diameters
4" (DN100) - 14" (DN359)

Advantages

- ✓ High filtering surface area
- ✓ Reduced number of moving parts and **low maintenance**
- ✓ **Highly reliable** and robust
- ✓ **Rapid and efficient** wash cycles

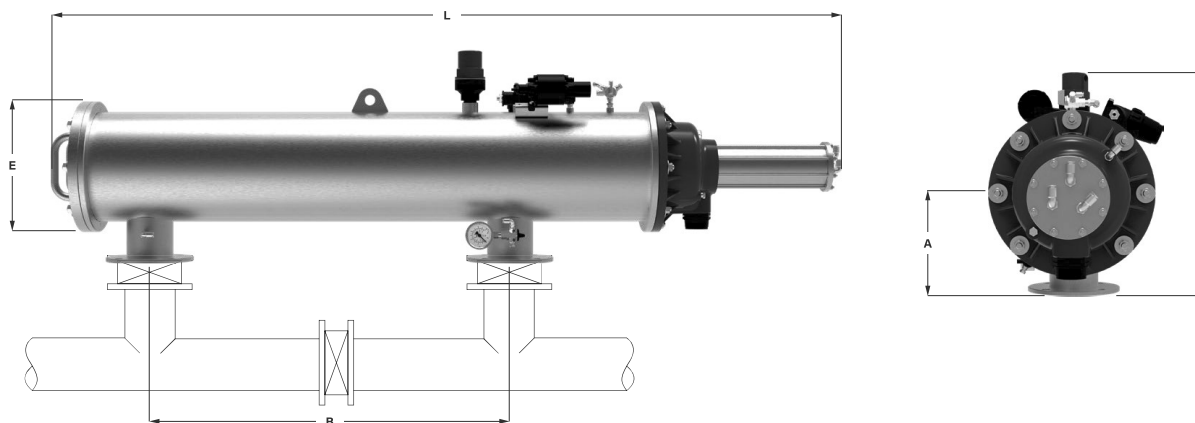

Model	Nominal Size D		IN/OUT connections	Nominal flow rate 2 m of pressure loss		Filtering surface cm ²	Size (mm)					Weight (kg)	
	inches	mm		litres/sec	m ³ /h		A	B	E	H	L	Empty	Full
FW100EX	4	100	DN100	28	100	5600	235	900	273	525	1952	85	165
FW100EXL	4	100	DN100	28	100	8115	235	900	325	525	2315	104	200
FW 150	6	150	DN150	50	180	5600	270	900	325	583	2017	105	215
FW150EX	6	150	DN150	50	180	8115	270	900	325	583	2380	115	265
FW 200	8	200	DN200	89	320	8115	270	900	325	583	2612	130	320
FW 250	10	250	DN250	111	400	8115	270	900	325	583	2615	155	345
FW 250EX	10	250	DN250	111	400	10415	310	1100	406	665	3105	235	540
FW 300	12	300	DN300	167	600	10415	310	1100	406	665	3105	240	550
FW 350	14	350	DN350	250	900	12170	310	1270	406	665	3105	285	595

FW100EX - 350



Conditions of use

MINIMUM OPERATING PRESSURE	200 kPa (2bar) always
MAXIMUM OPERATING PRESSURE	Standard 1000 kPa (10bar), higher pressure available on request
MAXIMUM OPERATING TEMPERATURE	65°C

Construction materials

FILTER BODY	AISI 304 stainless steel (316 and other grades available on request)
COVER	GRN (glass-reinforced nylon), stainless steel, EPDM and natural rubber
CLEANING MECHANISM	Stainless steel, brass, GRN
MAIN FILTER	316 stainless steel screen, GRN
PRE-FILTER	GRN
GASKETS	NBR
CONTROL UNIT	Acetal, stainless steel, brass, PVC
CONTROL UNIT PIPES	Polyethylene



Head loss diagram

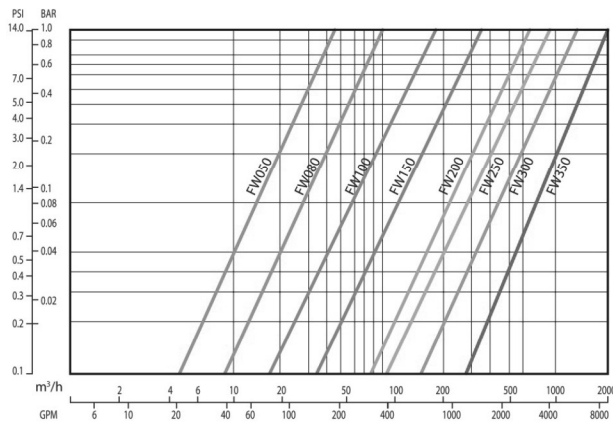

Notes

A series of horizontal dotted lines for taking notes.

Filtration | Filter automation kit

The result of Irritec's long experience in automatic filtration, these automation kits make it possible to fully automate Rotodisk Automatic filters and sand media filters in a practical and fast manner.

Available in different types to better suit the specific needs of each system.



FILTER AUTOMATION KIT

The result of Irritec's long experience in automatic filtration, these automation kits make it possible to fully automate Rotodisk Automatic filters and sand media filters in a practical and fast manner. Available in different types to better suit the specific needs of each system.



Advantages

- ✓ **Complete kits** for automated filter cleaning.
- ✓ Models with **Battery and / or 220 VAC power supply**
- ✓ **Differential DP Sensor**
- ✓ **Highly reliable solenoids**
- ✓ **Metal bracket** for quick mounting on all Irritec Automatic filters
- ✓ **Compatible with Rotodisk Automatic and sand media filters** (models with 3-way valves only)

Principle of operation

1. As a result of the differential DP Sensor, the control unit continuously detects the state of cleanliness of the filter.
2. The backwash control unit manages the wash times of each filter and is set according to water quality.
3. The washing cycles are carried out in 2 modes:
 - Timed: with defined time intervals
 - DP: based on the required DP Sensor values

Selecting the correct model

	KTB	KPB	KFB	KCB	KFA	KCA	
MODELS							
General Specifications	POWER SUPPLY				Battery		220 VAC
	SOLENOID TYPE				9 - 12 latch		24 VAC
	No. of OUTLETS (FILTERS)	1 - 4	2 - 8	2 - 10	2 - 15	2 - 10	2 - 15
Functions	DP SENSOR						integrated
	WASHING CYCLES HISTORY			No			Yes
	EXTERNAL ENABLING	Yes	No	Yes	No	Yes	

KTB



Functions

- ✓ D.P. is integrated and easy to replace
- ✓ D.P. values displayed in real time

Operating characteristics

- Time between washes (hh : mm)
- Wash time for each single element (mm: ss)
- Pause Time
- Delay time between filters
- Read current DP value
- DP setpoint for automatic wash operation
- Manual operation

Control unit specifications

DIMENSIONS	230x140x80 mm
WEIGHT	0.7 kg
BOX	ABS
IP RATING	IP-54
ELECTRICAL POWER SUPPLY	2.7 - 5 VDC
ABSORPTION CURRENT	20uA
WORKING TEMPERATURE	0°C to 60°C
WORK HUMIDITY	0 to 95% non-condensing
FUSES/ELECTRICAL PROTECTIONS	Resettable PolySwitch PTC
OUTPUTS	Transistor
OUTPUT VOLTAGE	18VDC Latch type

Solenoid specifications

OPERATING PRESSURE	0-10 bar
ORIFICE DIAMETER	1.5 mm
FLOW COEFFICIENT	Kv=0.08 m ³ /h a 1 bar DP

Materials

BODY	Nylon
GASKETS	NBR
"WET" PARTS	Stainless Steel and Polyamide

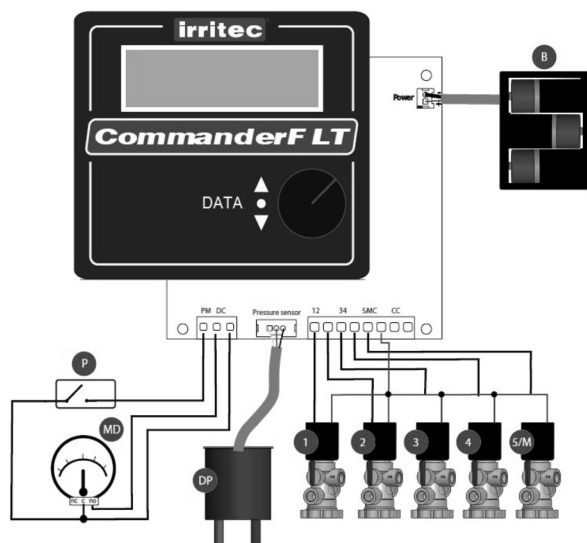

Electrical Specifications

VOLTAGE	9-40 VDC
RESISTANCE	6 ohm
INDUCTANCE	90 mH

KPB



Functions

- ✓ Analogue settings (no. x 3 knobs)
- ✓ Duration (Filter wash time)
- ✓ Cycle (max. pause time between washing cycles)
- ✓ D.P. setpoint for cycle activation
- ✓ Delay time between filters (Internal setting)

Control unit specifications

CONTAINER	IP 65 water resistant
POWER SUPPLY	2 x 1.5 VDC torch batteries (bridge not present) External power supply (with bridge)
OUTPUTS	No. x 4 stations (filter+master)
WASH TIMES (DURATION)	7-15-30 sec - 1-2-3-4-6-8-10-15-20 min.
WAIT TIMES (CYCLE)	15-30 min. - 1-2-3-4-8-10-12-24h.
INTERNAL PRESSURE SWITCH	Delta P 0.2-0.4-0.8-1.0-1.2-1.4-1.8-2.0-2.2 bar
OUTPUTS	Solenoids VDC Latch
DP SENSOR	Integrated analogue DP sensor; also compatible with external dry contact DP sensor

Solenoid specifications

OPERATING PRESSURE	0-10 bar
ORIFICE DIAMETER	1.5 mm
FLOW COEFFICIENT	Kv=0.08 m³/h a 1 bar DP

Materials

BODY	Nylon
GASKETS	NBR
"WET" PARTS	Stainless Steel and Polyamide

Electrical Specifications

VOLTAGE	9-40 VDC
RESISTANCE	6 ohm
INDUCTANCE	90 mH

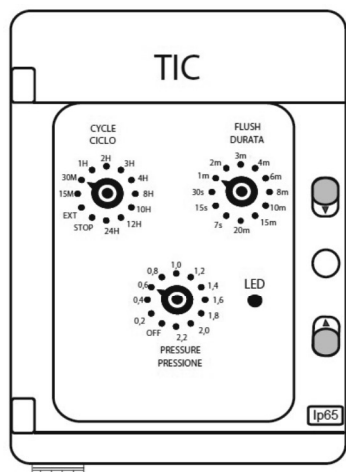

KFB



Functions

- ✓ BATTERY power supply / DC
- ✓ Duration (Filter wash time)
- ✓ Cycle (max. pause time between washing cycles)
- ✓ D.P. setpoint for cycle activation
- ✓ Delay time between filters
- ✓ Master Valve Delay
- ✓ Washing cycles history
- ✓ D.P. delay time
- ✓ D.P. values displayed in real time

Control unit specifications

POWER SUPPLY	4 x type D alkaline - 12 VDC
OUTPUTS	Solenoids 12 VDC latch
PRESSURE DIFF.:	Integrated analogue DP sensor; also compatible with external dry contact DP sensor
TEMPERATURE	0-60 °C

Solenoid specifications

OPERATING PRESSURE	0-10 bar
ORIFICE DIAMETER	1.5 mm
FLOW COEFFICIENT	Kv=0.08 m ³ /h a 1 bar DP

Materials

BODY	Nylon
GASKETS	NBR
"WET" PARTS	Stainless Steel and Polyamide

Electrical Specifications

VOLTAGE	9-40 VDC
RESISTANCE	6 ohm
INDUCTANCE	90 mH

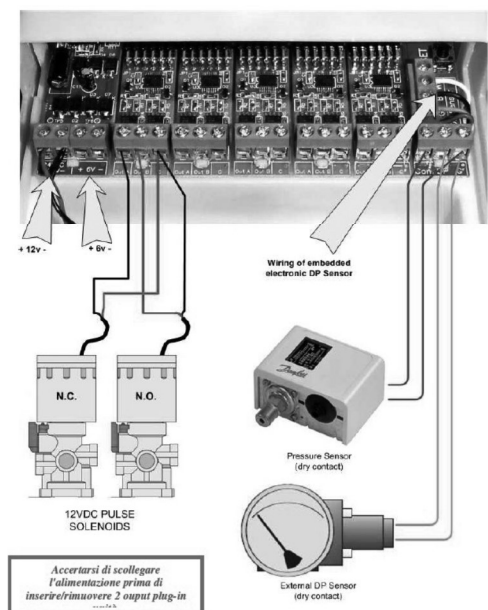

KFA



Functions

- ✓ BATTERY power supply / DC
- ✓ Duration (Filter wash time)
- ✓ Cycle (max. pause time between washing cycles)
- ✓ D.P. setpoint for cycle activation
- ✓ Delay time between filters
- ✓ Master Valve Delay
- ✓ Washing cycles history
- ✓ D.P. delay time
- ✓ D.P. values displayed in real time

Control unit specifications

POWER SUPPLY	220 VAC 60 Hz with integrated 24 VAC transformer
OUTPUTS	24 VAC
PRESSURE DIFF.:	Integrated analogue DP sensor; also compatible with external dry contact DP sensor
TEMPERATURE	0-60 °C

Solenoid specifications

OPERATING PRESSURE	0-10 bar
ORIFICE DIAMETER	1.5 mm
FLOW COEFFICIENT	Kv=0.08 m³/h a 1 bar DP

Materials

BODY	Nylon
GASKETS	NBR
"WET" PARTS	Stainless Steel and Polyamide

Electrical Specifications

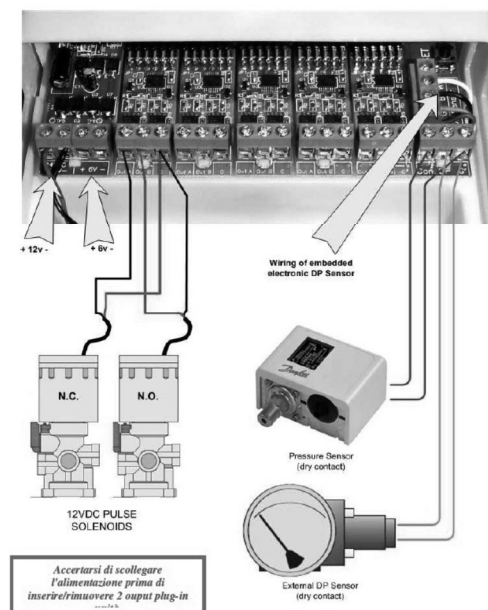

VOLTAGE	9-40 VDC
RESISTANCE	6 ohm
INDUCTANCE	90 mH











KCB

Functions

✓ Power supply 12 VDC

System	Brand	Standard / Regulation	Description	Body	Certificate no.
	 	UNI EN ISO 9001:2015	Quality Management System	Kiwa	19303 - A
		UNI EN ISO 14001:2015	Environmental Management System	Kiwa	19303 - E
		UNI EN ISO 45001:2018	Occupational Health and Safety Management System	Kiwa	19303 - I
	UE 952/2013	Authorised Economic Operator	Customs Agency and State Monopolies	IT AEOF 16 1155	

Product	Country	Brand	Standard	Description	Body	Certificate no.
	ITALY	 	UNI 9561:2006	Connecto™ +Ultra	Kiwa	KIP-107560
			UNI 7990:2015	Irritec® BD Genlene® BD drinkable	Kiwa	KIP-107561 KIP-107562
			UNI EN ISO 9261:2010	Dripline eXXtreme Tape® - irritecTape™	Kiwa	KIP-107564
				Dripline P1® - P0™ - P5™	Kiwa	KIP-107564
				Dripline D5™ - M5™ - D7™ - M7™	Kiwa	KIP-107564
				Dripline Tandem® - Junior® - Multibar™ C - Multibar™ C a.s.-d.s. - Multibar™ C Rootguard	Kiwa	KIP-107564
			Dripline Multibar™ F - Multibar™ F a.s - Multibar™ F a.s-d.s.	Kiwa	KIP-107564	
			Dripper iDrop® CCG - CCS - DCG - DCS - DNG	Kiwa	KIP-107564	
			UNI EN 12201-2:2013	Irritec® - Genlene®	Kiwa	KIP-107557
			UNI EN 1622:2006		Irritec® - Genlene®	Kiwa
	D.M. 174:2004					
	UNI EN 15494:2021	Irritec® - Genlene®	Kiwa	KIP-107559		
			ISO 8779:2020	Gpipe® - Irripepe®	Kiwa	KIP-107563
	GERMANY		GW 335-B3:2011	Connecto™ +Ultra	DVGW	DW-8616BT0102
SOUTH AFRICA		SANS 17885	Connecto™ +Ultra	SABS	8357/13262	
SWITZERLAND		TPW 157	Connecto™ +Ultra	SVGW	1103-K 298	
AUSTRALIA		AS/NZS 4129:2008	Connecto™ +Ultra	SAI GLOBAL	WMKA21524	
UNITED KINGDOM		BS 6920-1:2000	Connecto™ +Ultra	WRAS	1712054	



KCA



Functions

- ✓ Power supply 220 VAC
- ✓ Duration (Filter wash time)
- ✓ Cycle (max. pause time between washing cycles)
- ✓ D.P. setpoint for cycle activation
- ✓ Settable D.P. delay
- ✓ Delay time between filters
- ✓ Washing cycles history
- ✓ External enabling and operating windows
- ✓ Time-, D.P. or Volume-based washing cycles
- ✓ Different washing cycles can be set for different filters

Control unit specifications

DIMENSIONS	324 x 100 x 130 mm
WEIGHT	3 kg
CONTAINER MATERIAL	ABS
IP RATING	IP 54
ELECTRICAL POWER SUPPLY (+/- 10%)	220 VAC
CONSUMPTION	75 mA
OUTPUT ABSORPTION	20 mA
INPUT ABSORPTION	8 mA
BACKUP BATTERY	NI-CAD 3.6V - 110 mAH
BACKUP BATTERY LIFE (in OFF mode)	1 year
WORKING TEMPERATURE	0 - 60 °C
WORK HUMIDITY	0 - 95% (without condensing)
FUSE	0.5 Amp
OUTPUT TYPE	Via Relay
COMPATIBLE SOLENOIDS	24 VAC
OUTPUTS FUSE	4 Amp

Solenoid specifications

OPERATING PRESSURE	0-10 bar
ORIFICE DIAMETER	1.5 mm
FLOW COEFFICIENT	Kv=0.08 m³/h a 1 bar DP

Materials

BODY	Nylon
GASKETS	NBR
"WET" PARTS	Stainless Steel and Polyamide

Electrical Specifications

VOLTAGE	24 VDC
POWER	3.5 watt
CURRENT	Tip 0.20 amp Maintenance: 0.20 amp



CERTIFICATIONS

System	Brand	Standard / Regulation	Description	Body	Certificate no.
	 	UNI EN ISO 9001:2015	Quality Management System	Kiwa	19303 - A
		UNI EN ISO 14001:2015	Environmental Management System	Kiwa	19303 - E
		UNI EN ISO 45001:2018	Occupational Health and Safety Management System	Kiwa	19303 - I
	UE 952/2013	Authorised Economic Operator	Customs Agency and State Monopolies	IT AEOF 16 1155	

Product	Country	Brand	Standard	Description	Body	Certificate no.		
	ITALY	 	UNI 9561:2006	Connecto™ +Ultra	Kiwa	KIP-107560		
			UNI 7990:2015	Irritec® BD Genlene® BD drinkable	Kiwa	KIP-107561 KIP-107562		
			UNI EN ISO 9261:2010	Dripline eXXtreme Tape® - irritecTape™	Kiwa	KIP-107564		
				Dripline P1® - P0™ - P5™	Kiwa	KIP-107564		
				Dripline D5™ - M5™ - D7™ - M7™	Kiwa	KIP-107564		
				Dripline Tandem® - Junior® - Multibar™ C - Multibar™ C a.s.-d.s. - Multibar™ C Rootguard	Kiwa	KIP-107564		
				Dripline Multibar™ F - Multibar™ F a.s - Multibar™ F a.s-d.s.	Kiwa	KIP-107564		
				Dripper iDrop® CCG - CCS - DCG - DCS - DNG	Kiwa	KIP-107564		
			UNI EN 12201-2:2013		UNI EN 1622:2006	Irritec® - Genlene®	Kiwa	KIP-107557
			D.M. 174:2004					
	UNI EN 15494:2021	Kiwa	KIP-107559					
	GERMANY		ISO 8779:2020	Gpipe® - Irripepe®	Kiwa	KIP-107563		
	SOUTH AFRICA		GW 335-B3:2011	Connecto™ +Ultra	DVGW	DW-8616BT0102		
	SWITZERLAND		SANS 17885	Connecto™ +Ultra	SABS	8357/13262		
AUSTRALIA		TPW 157	Connecto™ +Ultra	SVGW	1103-K 298			
UNITED KINGDOM		AS/NZS 4129:2008	Connecto™ +Ultra	SAI GLOBAL	WMKA21524			
		BS 6920-1:2000	Connecto™ +Ultra	WRAS	1712054			



Irritec S.p.A. is a Benefit Corporation

Via Gambitta Conforto, C.da S. Lucia SNC - 98071 Capo d'Orlando (Me) - Italy
Tel. +39 0941 922111 - Fax +39 0941 958807 - www.irritec.com - irritec@irritec.com

© Any reproduction, publication, distribution or public display of the materials provided IN in this catalogue, in whole or in part, is strictly prohibited.

The information included in this catalogue is provided in good faith by Irritec S.p.A. and is checked periodically. However, we do not guarantee the accuracy and completeness of the information. Under no circumstance can Irritec S.p.A. be held liable for any direct or indirect damages which could derive from the use of the information included in this catalogue or from the contents of the site.

